

DATA HANDBOOK

Monochrome Monitor Tubes and Deflection Units

B | 0 | 0 | K | D | C | 0 | 2 | 1 | 9 | 9 | 1

Philips Components



PHILIPS

MONOCHROME MONITOR TUBES AND DEFLECTION UNITS

	<i>page</i>
Selection guide	
Monochrome monitor tubes	4
Flat square monochrome monitor tubes	5
Flat monochrome monitor tubes	6
Deflection units for monochrome monitor tubes	6
Recommended combinations for monochrome monitor tubes	9
General	
List of symbols	13
General operational recommendations	15
General data on monochrome monitor tubes	21
Type designation	25
Resolution characteristics for high resolution low cut-off gun	27
Resolution characteristics for high resolution high cut-off gun	33
High resolution low cut-off gun narrow neck	39
High resolution low cut-off gun wide neck	45
High resolution high cut-off gun narrow neck	51
High resolution high cut-off gun wide neck	57
Reference line gauges	61
Bases	63
Device specifications	
Monochrome monitor tubes	67
Deflection units for monochrome monitor tubes	371

SELECTION GUIDE

MONOCHROME MONITOR TUBES

face diagonal	type	deflection angle	useful screen diagonal mm	neck diameter mm	max. overall length mm	V _f /I _f V/mA	V _a kV	V _{g2} V	resolution (approx.) (number of lines)	page
24 cm (9 in)	M24-306	90°	222.5	20	227	12/130	12	700	1300	69
	M24-308									
	M24-310									
	M24-328									
24 cm (9 in)	M24-322	90°	222.5	20	227	12/75	12	700	1300	83
	M24-326									
	M24-330									
	M24-514W									
31 cm (12 in)	M31-340	90°	294	20	277	12/130	12	700	1300	155
	M31-342									
	M31-344									
	M31-346									
	M31-348									
	M31-362	90°	294	20	277	12/75	12	700	1300	183
	M31-364									
	M31-366									
	M31-336									
	M31-338	90°	292	20	280	12/130	12	700	1300	141
M31-350										
M31-354										
M31-380										
34 cm (14 in)	M31-382	90°	294	20	277	12/75	12	700	1300	209
	M32EAA									
	M32EBF									
	M32EAB									
	M32EAK									
	M32ECD									

face diagonal	type	deflection angle	useful screen diagonal mm	neck diameter mm	max. overall length mm	V _f /I _f V/mA	V _a kV	V _{g2} V	resolution (approx.) (number of lines)	page
38 cm (15 in)	M38-328	110°	352	28.6	290	6.3/240	17	700	1500	307
	M38-330									
	M38-334									
	M38-336									
	M38-338									
44 cm (17 in)	M38-342	110°	352	28.6	290	12/130	17	700	1500	323
	M38-348	114°	413	28.6	302	6.3/240	20	700	1500	335
50 cm (20 in)	M41EAA	114°	473	28.6	330	6.3/240	20	700	1400	347
	M47EAA M47EAB	114°	473	28.6	330	6.3/240	20	700	1400	347

FLAT SQUARE MONOCHROME MONITOR TUBES

31 cm (12 in)	M29EAA	90°	294	20	275	12/130	12	700	1300	117
	M29EAB									
	M29ECA M29ECB									
36 cm (15 in)	M36EAB	110°	363	28.6	287	6.3/240	17	700	1500	295
	M36ECJ									

FLAT MONOCHROME MONITOR TUBES

face diagonal	type	deflection angle	useful screen diagonal mm	neck diameter mm	max. overall length mm	V _f /I _f V/mA	V _a kV	V _{g2} V	resolution (approx.) (number of lines)	page
34 cm (14 in)	M32EBJ	90°	319	20	282	12/130	14	700	1300	247
	M32EBL	90°	319	20	282	12/130	14	700	1300	283
	M32ECB	90°	319	20	282	12/75	14	700	1300	259
	M32EBM	90°	317	20	282	12/130	14	700	1300	271
	M32EBN	90°	317	20	282	12/130	14	700	1300	271

DEFLECTION UNITS FOR MONOCHROME MONITOR TUBES

tube face diagonal	type	deflection angle	tube neck diameter mm	line coils			field coils			sensitivity			page
				inductance μH	resistance Ω	resistance Ω	inductance mH	resistance Ω	at EHT kV	raster scan current			
										line A(p-p)	field A(p-p)		
31 cm (12 in) landscape	AT1039/03	110°	28.6	228.5 (note 1)	0.41 (note 1)	10.2 (note 1)	9.18 (note 1)	10.2 (note 1)	17	7.34	1.03	389	
36 cm (15 in) portrait	AT1039/20 (note 2)	110°	28.6	233 (note 1)	0.38 (note 1)	10.0 (note 1)	8.80 (note 1)	10.4 (note 1)	17	5.66	1.32	413	
36 cm (15 in) landscape	AT1039/21 (note 2)	110°	28.6	205 (note 1)	0.35 (note 1)	10.4 (note 1)	9.50 (note 1)	10.4 (note 1)	17	7.64	0.95	413	
38 cm (15 in) portrait	AT1039/00	110°	28.6	225 (note 1)	0.39 (note 1)	10.2 (note 1)	9.18 (note 1)	10.2 (note 1)	17	5.60	1.15	381	
38 cm (15 in) landscape	AT1039/01 AT1039/05	110° 110°	28.6 28.6	206 107.5 (note 1)	0.38 0.18 (note 1)	10.5 10.4 (note 1)	9.60 9.50 (note 1)	10.5 10.4 (note 1)	17 17	7.55 10.50	0.90 0.95	381 397	

SELECTION GUIDE

tube face diagonal	type	deflection angle	tube neck diameter	line coils		field coils		sensitivity			page
				inductance μ H	resistance Ω	inductance mH	resistance Ω	at EHT kV	raster scan current		
									line A (p-p)	field A (p-p)	
41/47 cm (17/20 in) portrait	AT1039/08	110°	28.6	230 (note 1)	0.39 (note 1)	9.30 (note 1)	10.4 (note 1)	20	6.27	1.39	405
41/47 cm (17/20 in) landscape	AT1039/09 AT1039/39	110° 110°	28.6 28.6	213 111	0.37 0.18	9.50 9.50	10.5 10.4	20 17.5	8.16 11.00	1.08 1.04	405 421
38 cm landscape	AT1039/15	110°	28.6	278	0.48	9.9	10.8	17.0	6.23	0.88	—
41/47 cm (17/20 in) high frequency landscape (note 5)	AT1037/01S	110°	28.6	72	0.14	12.2	13.5	17.5	13.10	0.87	373
41/47 cm landscape (note 5)	AT1037/02S	110°	28.6	72	0.14	6.0	7.4	19.8	14.10	1.35	—
41/47 cm landscape (note 5)	AT1037/03S	110°	28.6	72	0.14	6.0	6.0	18.0	13.50	1.33	—
41/47 cm landscape (note 5)	AT1037/05S	110°	28.6	72	0.14	5.75	6.4	20.0	14.20	1.38	—
51 cm (21") landscape (note 3)	AT1037/12	110°	28.6	105	0.21	6.0	7.4	18.5	11.0	1.33	—

tube face diagonal	type	deflection angle	tube neck diameter	line coils		field coils		sensitivity		page	
				inductance μH	resistance Ω	inductance mH	resistance Ω	at EHT kV	raster scan current line field A (p-p) A (p-p)		
41/47 cm landscape (note 5)	AT1037/15S	110°	28.6	105	0.21	12.2	13.5	20.0	10.7	0.87	—
51 cm (21") landscape (note 3)	AT1037/17	110°	28.6	72	0.14	12.2	13.5	19.0	13.8	0.89	—
41 cm (17") landscape (note 5)	AT1037/41S	110°	28.6	72	0.14	5.75	6.3	20.0	14.5	1.40	—
41 cm (17") landscape (note 4)	AT1037/45	110°	28.6	72	0.14	12.2	13.5	18.0	12.8	0.85	—

Notes

1. Coils can be connected in series or parallel. The indicated values apply to parallel-connected line coils, and series-connected field coils.
2. For flat square application.
3. AT1037/12 and AT1037/17 are designed for Toshiba 21" FS tube E8130.
4. AT1037/45 is designed for Clinton 17" flat tube CE925M17.
5. AT1037 types with suffix 'S' are designed for use with Philips tubes.
6. Type numbers with an odd stroke number have litze-wire in the line coil only. Type numbers with an even stroke number have litze-wire in both the line and frame coils.

RECOMMENDED COMBINATIONS FOR MONOCHROME
DATA GRAPHIC DISPLAYS

Design designation	C64, C64-FS	C64, C64-FS	C64-LITZE
Deflection angle	110°	110°	110°
Format	landscape	portrait	landscape
Tube			
12-inch	M31-326	—	—
15-inch	M38-328	M38-328	—
15-inch FS	M36ECJ	M36ECJ	—
17-inch	M41EAA	M41EAA	M41EAA
20-inch	M47EAA	M47EAA	M47EAA
Deflection unit			
12-inch	AT1039/03	—	—
15-inch	AT1039/01	AT1039/00	—
15-inch FS	AT1039/21	AT1039/20	—
17-inch	AT1030/09	AT1039/08	AT1037/01
20-inch	AT1039/09	AT1039/08	AT1037/01
Line output transformer	AT2077/84*	AT2077/84*	AT2077/84*
Linearity control	AT4042/33A	AT4042/33A	AT4042/33A
Line driver transformer	AT4043/64	AT4043/64	AT4043/64
Shift transformer	AT4043/29	AT4043/29	AT4043/29
Width control	AT4044/35	AT4044/35	AT4044/35
Characters per line	100 - 132	100 - 132	100 - 132
Supply voltage (V)	30 - 120	30 - 120	30 - 120
EHT (kV)	17 - 20	17	18
Line frequency (kHz)	15 - 50	15 - 70	15 - 70

* EHT cable, catalogue number 3122 137 63370, to be ordered separately.

GENERAL

LIST OF SYMBOLS

Symbols denoting electrodes/elements and electrode/element connections

f	Heater
k	Cathode
g	Grid: Grids are distinguished by means of an additional numeral; the electrode nearest to the cathode having the lowest number.
a	Anode
m	External conductive coating
m ¹	Rimband or tension band (T-band)
ℓ	Fluorescent screen
i.c.	Tube pin which must not be connected externally
n.c.	Tube pin which may be connected externally

Symbols denoting voltages

Unless otherwise stated, the reference point for electrode voltages is the cathode.

V	Symbol for voltage, followed by a subscript denoting the relevant electrode/element
V _f	Heater voltage
V _(p-p)	Peak-to-peak value of a voltage
V _p	Peak value of a voltage
V _{GR}	Grid 1 voltage for visual extinction of focused raster (grid drive service)
V _{KR}	Cathode voltage for visual extinction of focused raster (cathode drive service)

Symbols denoting currents

I	Symbol for current followed by a subscript denoting the relevant electrode
I _f	Heater current (r.m.s. value)

Note: The symbols quoted represent the average value of the current, unless otherwise stated.

Symbols denoting powers

P _ℓ	Dissipation of the fluorescent screen
P _g	Grid dissipation

Symbols denoting capacitances

See IEC publication 100

Symbols denoting resistances and impedances

R	Symbol for resistance followed by a subscript for the relevant electrode pair. When only one subscript is given the second electrode is the cathode.
Z	Symbol for impedance followed by a subscript for the relevant electrode pair. When only one subscript is given the second electrode is the cathode.

Symbols denoting various quantities

L	Luminance
f	Frequency
H	Magnetic field strength

GENERAL OPERATIONAL RECOMMENDATIONS

INTRODUCTION

Equipment design should be based on the characteristics as stated in the data sheets. Where deviations from these general recommendations are permissible or necessary, statements to that effect will be made.

If applications are considered which are not referred to in the data sheets of the relevant tube type extra care should be taken with circuit design to prevent the tube being overloaded due to unfavourable operating conditions.

SPREAD IN TUBE CHARACTERISTICS

The spread in tube characteristics is the difference between maximum and minimum values. Values not qualified as maximum or minimum are nominal ones. It is evident that average or nominal values, as well as spread figures, may differ according to the number of tubes of a certain type that are being checked. No guarantee is given for values of characteristics in settings substantially differing from those specified in the data sheets.

SPREAD AND VARIATION IN OPERATING CONDITIONS

The operating conditions of a tube are subject to spread and/or variation.

Spread in an operating condition is a **permanent** deviation from an average condition due to, e.g., component value deviations. The average condition is found from such a number individual cases taken at random that an increase of the number will have a negligible influence.

Variation in an operating condition is **non-permanent** (occurs as a function of time), e.g., due to supply voltage fluctuations. The average value is calculated over a period such that a prolongation of that period will have negligible influence.

LIMITING VALUES

Limiting values are in accordance with the applicable rating system as defined by IEC publication 134. Reference may be made to one of the following 3 rating systems.

Absolute maximum rating system. Absolute maximum ratings are limiting values of operating and environmental conditions applicable to any electronic device of a specified type as defined by its published data, and should not be exceeded under the worst probable conditions. These values are chosen by the device manufacturer to provide acceptable serviceability of the device, taking no responsibility for equipment variations, environmental variations, and the effects of changes in operating conditions due to variations in the characteristics of the device under consideration and of all other electronic devices in the equipment.

The equipment manufacturer should design so that, initially and throughout life, no absolute maximum value for the intended service is exceeded with any device under the worst probable operating conditions with respect to supply voltage variation, equipment components spread and variation, equipment control adjustment, load variations, signal variation, environmental conditions, and spread or variations in characteristics of the device under consideration and of all other electronic devices in the equipment.

Design-maximum rating system. Design-maximum ratings are limiting values of operating and environmental conditions applicable to a bogey electronic device* of a specified type as defined by its published data, and should not be exceeded under the worst probable conditions.

These values are chosen by the device manufacturer to provide acceptable serviceability of the device, taking responsibility for the effects of changes in operating conditions due to variations in the characteristics of the electronic device under consideration.

The equipment manufacturer should design so that, initially and throughout life, no design-maximum value for the intended service is exceeded with a bogey device under the worst probable operating conditions with respect to supply-voltage variation, equipment component variation, variation in characteristics of all other devices in the equipment, equipment control adjustment, load variation, signal variation and environmental conditions.

Design-centre rating system. Design-centre ratings are limiting values of operating and environmental conditions applicable to a bogey electronic device* of a specified type as defined by its published data, and should not be exceeded under average conditions.

These values are chosen by the device manufacturer to provide acceptable serviceability of the device in average applications, taking responsibility for normal changes in operating conditions due to rated supply-voltage variation, equipment component spread and variation, equipment control adjustment, load variation, signal variation, environmental conditions, and variations or spread in the characteristics of all electronic devices.

The equipment manufacturer should design so that, initially, no design-centre value for the intended service is exceeded with a bogey electronic device* in equipment operating at the stated normal supply voltage.

If the tube data specify limiting values according to more than one rating system the circuit has to be designed so that none of these limiting values is exceeded under the relevant conditions.

In addition to the limiting values given in the individual data sheets the directives in the following paragraphs should be observed.

HEATER SUPPLY

For maximum cathode life it is recommended that the heater supply be stabilized at the nominal heater voltage, + 0%, -5%. Any deviation from this heater voltage has a detrimental effect on tube performance and life, and should therefore be kept to a minimum. Such deviations may be caused by:

- mains voltage fluctuations;
- spread in the characteristics of components such as transformers, resistors, capacitors, etc.;
- spread in circuit adjustments;
- operational variations.

Supply from mains transformer

The maximum deviation of the heater voltage must not exceed + 5/-10% (Design Maximum Value).

Supply from line output transformer

A deviation from the nominal heater voltage due to spread in component characteristics and adjustments should not exceed $\pm 7,5\%$. Considering all other possible deviations, due to mains voltage variations, beam current variations, VCR-operation, etc., the total spread in heater voltage must not exceed + 5/-10%.

* A bogey tube is a tube whose characteristics have the published nominal values for the type. A bogey tube for any particular application can be obtained by considering only those characteristics which are directly related to the application.

Standby (instant-on circuits)

The majority of tubes employ quick-heating cathodes and therefore an instant-on circuit is superfluous. If used, it is recommended that the heater voltage of the tubes be reduced during standby operation to 75% of the nominal value.

Notes: If series connection of the heater circuit has to be used, and only parallel connection is quoted in the data sheet, please contact your local supplier.

Picture tubes with quick-heating cathodes should not be used in series with receiving tubes.

CATHODE TO HEATER VOLTAGE

The voltage between cathode and heater should be as low as possible and never exceed the limiting values given in the data sheets of the individual tubes. The limiting values relate to that side of the heater where the voltage between cathode and heater is greatest. The voltage between cathode and heater may be d.c., a.c., or a combination of both. Unless otherwise stated, the maximum values quoted indicate the maximum permissible d.c. voltage. If a combination of d.c. and a.c. voltages is applied, the peak value may be twice the rated V_{kf} ; however, unless otherwise stated, this peak value shall never exceed 315 V. Unless otherwise stated, the V_{kf} max. holds for both polarities of the voltage; however, a positive cathode is usually the most favourable in view of insulation during life.

In order to avoid excessive hum the a.c. component of the heater to cathode voltage should be as low as possible and never exceed 20 V r.m.s. (mains frequency). A d.c. connection should always be present between heater and cathode. Unless otherwise specified the maximum resistance should not exceed 1 M Ω ; the maximum impedance at mains frequency should be less than 100 k Ω .

INTERMEDIATE ELECTRODES (between cathode and final accelerator)

In no circumstances should the tube be operated without a d.c. connection between each electrode and the cathode. The total effective impedance between each electrode and the cathode should never exceed the published maximum value. However, no electrode should be connected directly to a high energy source. When such a connection is required, it should be made via a series resistor of not less than 1 k Ω .

CUT-OFF VOLTAGE

Curves showing the limits of the cut-off voltage as a function of grid 2 voltage are generally included in the data. The brightness control should be so dimensioned that it can handle any tube within the limits shown, at the appropriate grid 2 voltage.

The published limits are determined at an ambient illumination level of 10 lux. Because the brightness of a spot is in general greater than that of a raster of the same current, the cut-off voltage determined with the aid of a focused spot will be more negative by about 5 V as compared with that of a focused raster.

FOCUSING ELECTRODE VOLTAGE

Individual tubes will have satisfactory focus over the entire screen at some value within the published range of the focusing voltage.

Due to their flat focus characteristics, black and white picture tubes can generally be operated at a fixed focusing voltage within the published range. Monochrome data graphic display tubes should have adjustable focus.

LUMINESCENT SCREEN

To prevent permanent screen damage, care should be taken:

- not to operate the tube with a stationary picture at high beam currents for extended periods;
- not to operate the tube with a stationary or slowly moving spot except at extremely low beam currents;
- if no e.h.t. bleeder is used, to choose the time constants of the cathode, grid 1, grid 2, and deflection circuits, such that sufficient beam current is maintained to discharge the e.h.t. capacitance before deflection has ceased after equipment has been switched off.

EXTERNAL CONDUCTIVE COATING

The external conductive coating must be connected to the chassis. The capacitance of this coating to the final accelerating electrode may be used to provide smoothing for the e.h.t. supply.

The coating is not a perfect conductor and in order to reduce electromagnetic radiation caused by the line time base and the picture content it may be necessary to make multiple connections to the coating. See also 'Flashover'.

METAL RIMBAND

An appreciable capacitance exists between the metal rimbands and the internal conductive coating of the tube; its value is quoted in the individual data sheets. To avoid electric shock, a d.c. connection should be provided between the metal band and the external conductive coating. In receivers where the chassis can be connected directly to the mains there is a risk of electric shock if access is made to the metal band. To reduce the shock to the safe limit, it is suggested that a $2\text{ M}\Omega$ resistor capable of handling the peak voltages be inserted between the metal band and the point of contact with the external conductive coating. This safety arrangement will provide the necessary insulation from the mains but in the event of flashover high voltages will be induced on the metal band. It is therefore recommended that the $2\text{ M}\Omega$ resistor be bypassed by a $4,7\text{ nF}$ capacitor capable of withstanding the peak voltage determined by the voltage divider formed by this capacitor and the capacitance of the metal rimbands to the internal conductive coating, and the anode voltage. The $4,7\text{ nF}$ capacitor also serves to improve e.h.t. smoothing by adding the rimbands capacitance to the capacitance of the outer conductive coating.

FLASHOVER

High electric field strengths are present between the gun electrodes of picture tubes. Voltages between gun electrodes may reach values of 20 kV over approx. 1 mm. Although the utmost precautions are taken in the design and manufacture of the tubes, there is always a chance that flashover will occur. The resulting transient currents and voltages may be of sufficient magnitude to cause damage to the tube itself and to various components on the chassis. Arcing terminates when the e.h.t. capacitor is discharged. Therefore it is of vital importance to provide protective circuits with spark gaps and series resistors, which should be connected according to Fig. 1. No other connections between the outer conductive coating and the chassis are permissible.

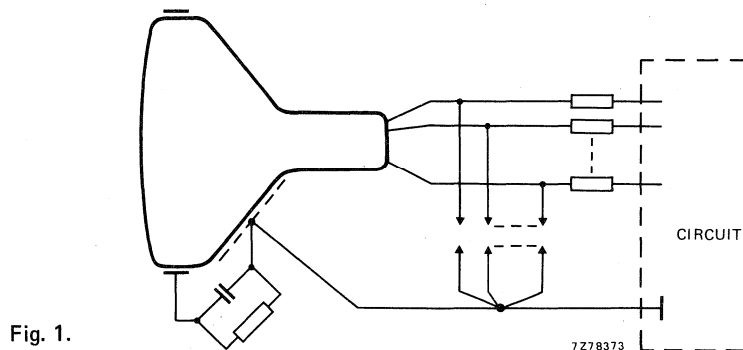

Fig. 1.

IMPLOSION PROTECTION

All picture tubes employ integral implosion protection and must be replaced with a tube of the same type number or recommended replacement to assure continued safety.

HANDLING

Although all picture tubes are provided with integral implosion protection, which meets the intrinsic protection requirements stipulated in the relevant part of IEC 65, care should be taken not to scratch or knock any part of the tube. **Stress on the tube neck must be avoided.**

When lifting a tube from the edge-down position, one hand should be placed around the parabola section of the cone and the other hand should be placed under the rim band (Fig. 2).

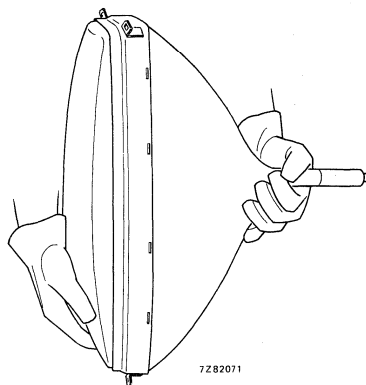

Fig. 2 Lifting picture tube from edge-down position.

When placing a tube face downwards ensure that the screen rests on a soft pad of suitable material, kept free from abrasive substances. When lifting from the face-down position the hand should be placed under the areas of the faceplate close to the mounting lugs at diagonally opposite corners of the faceplate (Fig. 3).

When lifting from the face-up position the hands should be placed under the areas of the cone close to the mounting lugs at diagonally opposite corners of the cone (Fig. 4).

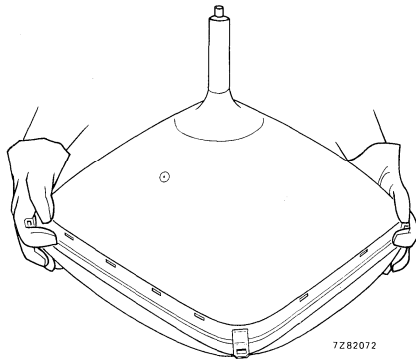

Fig. 3 Lifting picture tube from face-down position.

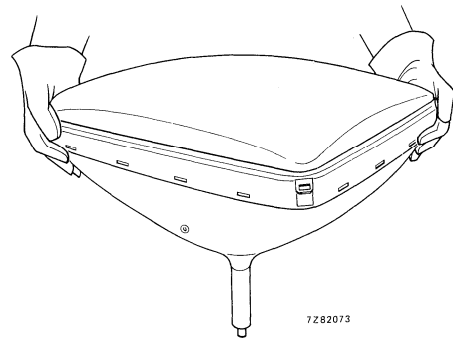

Fig. 4 Lifting tube from face-up position.

In all handling procedures prior to insertion in the receiver cabinet there is a risk of personal injury as a result of severe accidental damage to the tube. It is therefore recommended that protective clothing should be worn, **particularly eye shielding**.

If suspending the tube from the mounting lugs ensure that a **minimum of 2** are used; **UNDER NO CIRCUMSTANCES HANG THE TUBE FROM ONE LUG.**

Remember when replacing or servicing the picture tube that a residual electrical charge may be carried by the anode contact and also the external coating if not earthed. Before removing the tube from the equipment, earth the external coating and short the anode contact to the coating.

PACKING

The packing provides protection against tube damage under normal conditions of shipment or handling. Observe any instructions given on the packing and handle accordingly. The tube or tube/deflection yoke combination should under no circumstances be subjected to accelerations greater than 70 g (700 m/s²).

MOUNTING

Unless otherwise specified on the data sheets for individual tubes there are no restrictions on the position of mounting.

The tube socket should not be rigidly mounted but should have flexible leads and be allowed to move freely.

The mass of the socket and additional circuitry should not be more than 150 g. The socket of tubes with a 7-pin miniature base may not be used for mounting components.

It is very desirable that tubes should not be exposed to strong electrostatic and magnetic fields.

To achieve minimum bezel gap, it is recommended to use the nominal Z-lug value with minus 0.5 to 1.0 mm, provided that the rear cover is correctly fitted.

DIMENSIONS

In designing the equipment the tolerances given on the dimensional drawings should be considered. Under no circumstances should the equipment be designed around dimensions taken from individual tubes.

REFERENCE LINE

Where a reference line is indicated on the tube outline drawing, it is determined by means of a gauge. Drawings of the gauges are given in this section under "Reference line gauges".

GENERAL DATA ON MONOCHROME DISPLAY TUBES

Glass transmission

Two types of screen glass are available:

- normal tinted glass,
- dark tinted glass, for improved contrast.

The light transmission at the screen centre of both types is shown in the table below.

tube	normal tinted glass	dark tinted glass
24 cm (9 in), 90°	approx. 52%	approx. 42%
29 cm (12 in), 90°*	approx. 42%	approx. 31%
31 cm (12 in), 90°; 3 x 4	approx. 46%	approx. 34%
31 cm (12 in), 90°; 4 x 5	approx. 46%	approx. 34%
31 cm (12 in), 110°	approx. 46%	approx. 34%
34 cm (14 in), 90°	approx. 46%	approx. 34%
34 cm (14 in), 90°**	approx. 42%	approx. 31%
38 cm (15 in), 110°	approx. 46%	approx. 34%
38 cm (15 in), 110°*	approx. 42%	approx. 31%
41 cm (17 in), 114°	approx. 48%	approx. 32%
47 cm (20 in), 114°	approx. 46%	approx. 34%

Screen surface treatments

Two types of anti-glare treatments are available:

- direct grind, i.e. the screen is ground to an ultrafine finish that minimizes reflection without blurring the image or decreasing resolution,
- direct etch, i.e. the screen is etched to a finish that diffuses specular reflection.

* Flat square high resolution monochrome display tube.

** Flat high resolution monochrome display tube.

Survey of screen phosphors

type	designation	fluorescent colour	phosphorescent colour	persistence*	colour co-ordinates x	y	relative brightness (%) with respect to type WW
WW	P4	white	white	medium short	0.265	0.295	100
WS	P104	white	white	medium short	0.285	0.320	approx. 110
WJ	P115	white	white	medium short	0.315	0.355	approx. 120
WT	P192	white	white	medium	0.340	0.380	approx. 65
WR	—	white	white	medium short	0.355	0.395	approx. 130
WD	—	white	white	medium	0.355	0.395	approx. 65
GH	P31	green	green	medium short	0.265	0.550	approx. 150
GR	P39	yellowish-green	yellowish-green	long	0.205	0.715	approx. 75
GW	P42	yellowish-green	yellowish-green	medium	0.238	0.568	approx. 120
HA	—	yellowish-green	yellowish-green	medium	0.220	0.660	approx. 85
HJ	—	yellowish-green	yellowish-green	medium	0.240	0.700	approx. 80
—	(EPU)	greenish-yellow	greenish-yellow	medium	0.465	0.515	approx. 65
KC	—	yellow-green	yellow-green	medium short	0.425	0.550	approx. 170
LA	—	orange	orange	medium	0.554	0.446	approx. 50
LM	—	orange	orange	medium short	0.547	0.446	approx. 85

* medium short: 10 to 1000 μ s

medium: 1 to 100 ms

long: 100 ms to 1 s

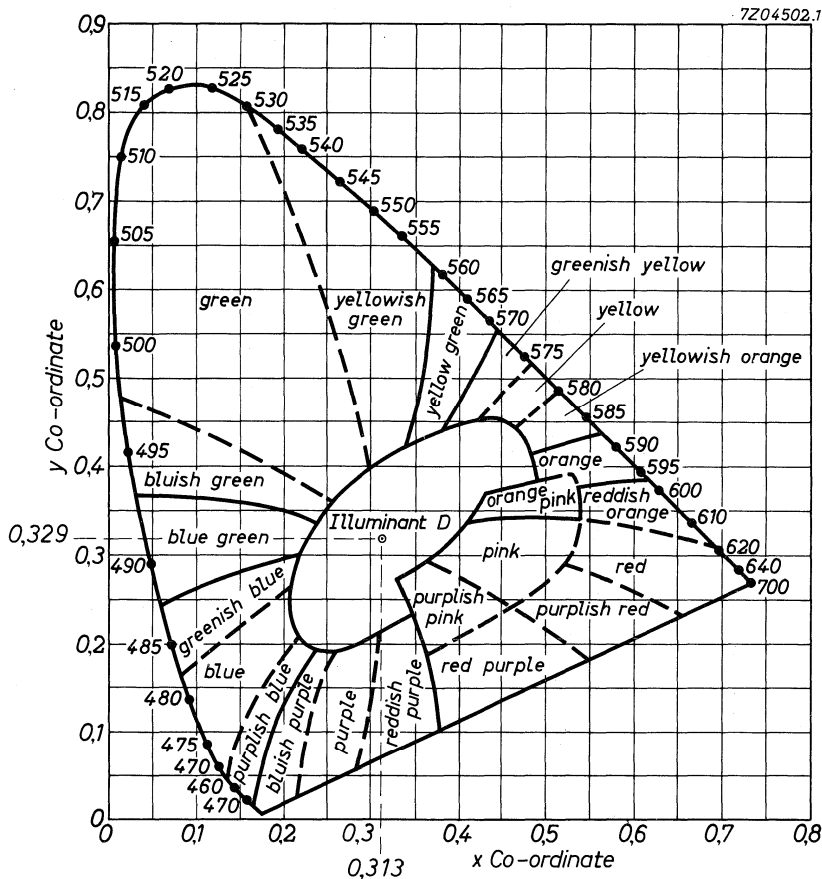

Fig. 1 Kelly chart.

TYPE DESIGNATION

Screen glass, screen surface treatment and phosphor are identified by the complete type designation. In the **old system**, used for type numbers M24-306, M31-340, etc., surface treatment and type of screen glass are identified by a type number suffix, as shown in the table below.

Table 1 Type number suffix

surface treatment	screen glass	suffix
normal glare	normal tinted	no
direct grind	normal tinted	/P
direct etch	normal tinted	/E
direct grind	dark tinted	/PD
direct etch	dark tinted	/ED

- For tubes without contact strip between external coating and mounting hardware the suffix is:/. . 3.
- For tubes with an internal surge limiter the suffix is:/. . 4.
- For tubes with the new generation mark 2 gun the suffix is:/. . 6.
- For tubes with a ring trap base the suffix is:/. . 7.
- For tubes with an anti static coating (ASC) the suffix is:/. . S.

Example:

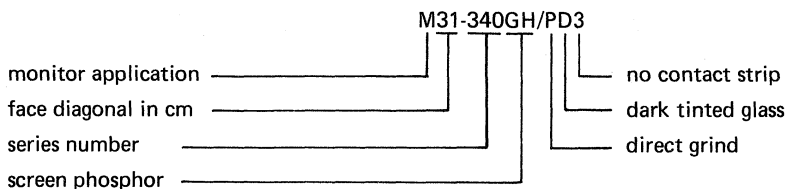

In the **new system**, used for type numbers M29EAA, M32EAA, etc., surface treatment and type of screen glass are identified as shown in the example below.

Example:

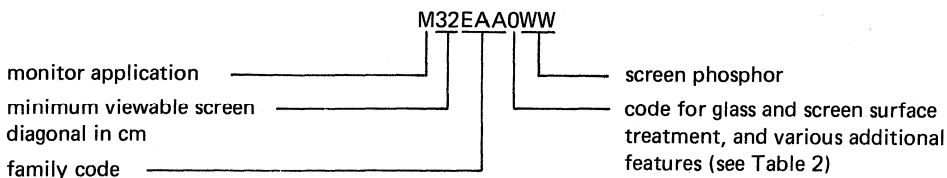

Table 2 Codes for glass and screen surface treatments and various additional features

code	glass		anti-glare			ISL	no contact strip	high cut-off gun	without anti-crackling coating
	normal tinted	dark tinted	normal glare	direct grind	direct etch				
0	X		X						
1	X			X					
2		X		X					
3		X			X				
5	X		X			X			
6		X		X			X		
7	X			X		X			
8	X				X				
10	X		X					X	
11	X			X				X	
12		X		X				X	
13		X			X			X	
15	X		X			X		X	
16		X		X			X	X	
17	X			X		X		X	
18	X				X			X	
20		X		X		X			
21	X		X			X			X
22		X		X		X		X	
23		X			X		X	X	
24		X			X	X			
27		X		X		X		X	X
28		X			X	X		X	

Table 3 Tube type and cathode classification

gun	narrow neck high resolution		wide neck high resolution			
	high cut-off	low cut-off	high cut-off		low cut-off	
tube size	9", 12", 14"	9", 12", 14"	12"/15"	17"/20"	12"/15"	17"/20"
cathode						
12 V/130 mA	X	X	X		X	
12 V/75 mA		X				
6.3 V/240 mA			X	X	X	X

RESOLUTION CHARACTERISTICS FOR THE HIGH RESOLUTION LOW CUT-OFF GUN

The following graphs (Figs 1 to 9) represent the line width as a function of the cathode cut-off voltage at a constant anode current (shrinking raster method), at screen centre for different display tubes. The grid 2 voltage varies to obtain cut-off.

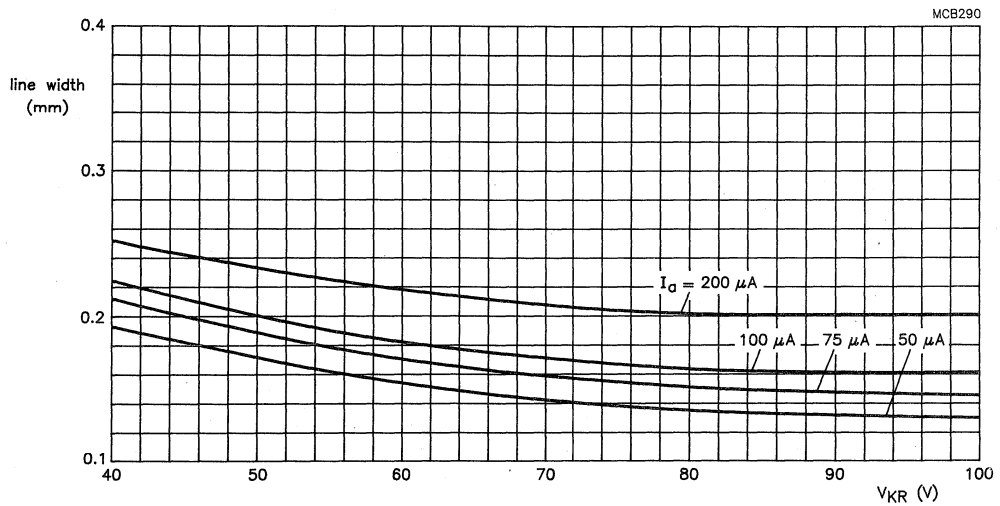

Fig.1 9 inch tube; 90° deflection angle; $V_a = 12$ kV; raster dimensions 126 mm x 168 mm; 241 active lines at 60 Hz repetition frequency.

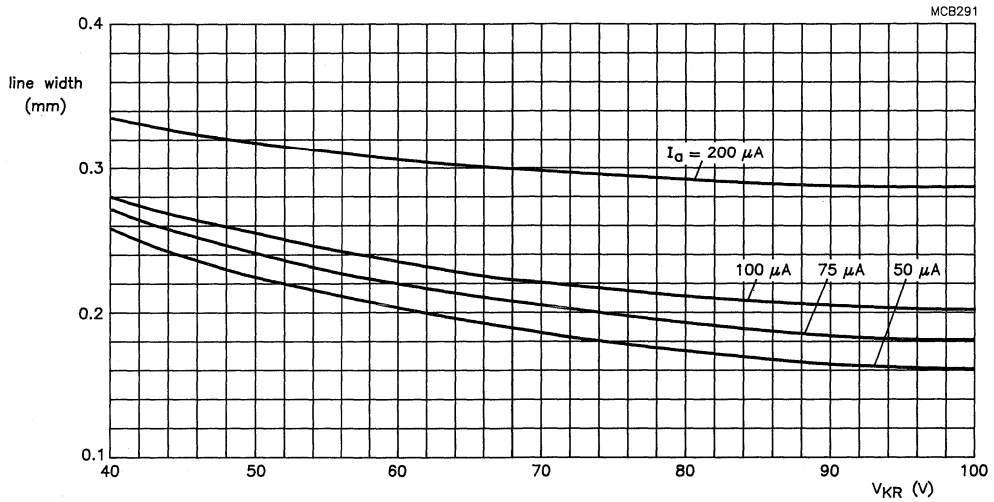

Fig.2 12 inch tube; 90° deflection angle; $V_a = 12$ kV; raster dimensions 162 mm x 216 mm; 241 active lines at 60 Hz repetition frequency.

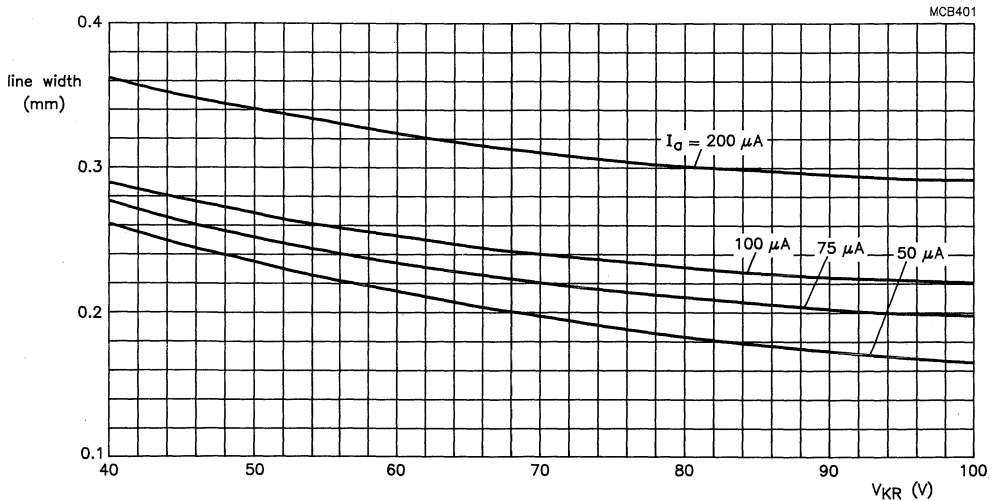

Fig.3 12 inch flat square tube; 90° deflection angle; $V_a = 12$ kV; raster dimensions 162 mm x 216 mm; 241 active lines at 60 Hz repetition frequency.

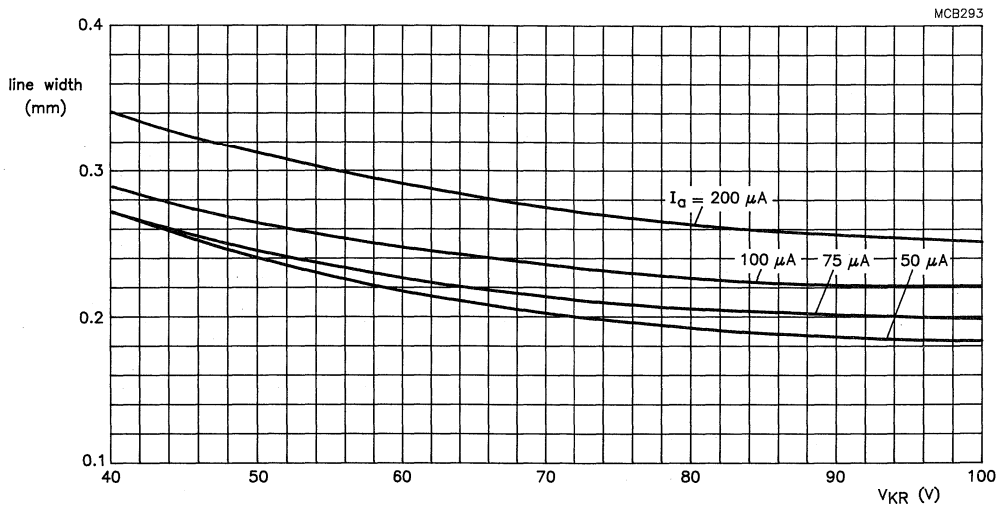

Fig.4 14 inch tube; 90° deflection angle; $V_a = 14$ kV; raster dimensions 178 mm x 237 mm; 241 active lines at 60 Hz repetition frequency.

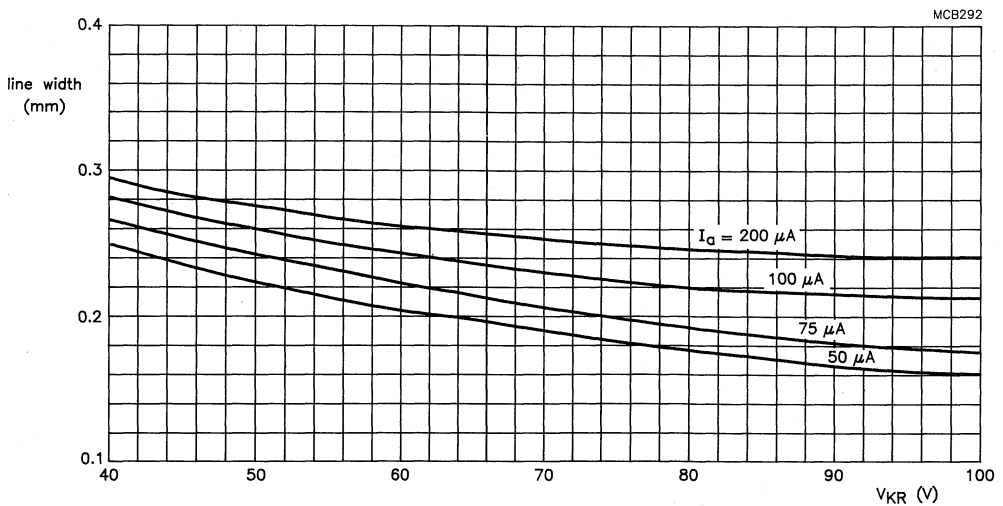

Fig.5 14 inch flat tube; 90° deflection angle; $V_a = 14$ kV; raster dimensions 178 mm x 237 mm; 241 active lines at 60 Hz repetition frequency.

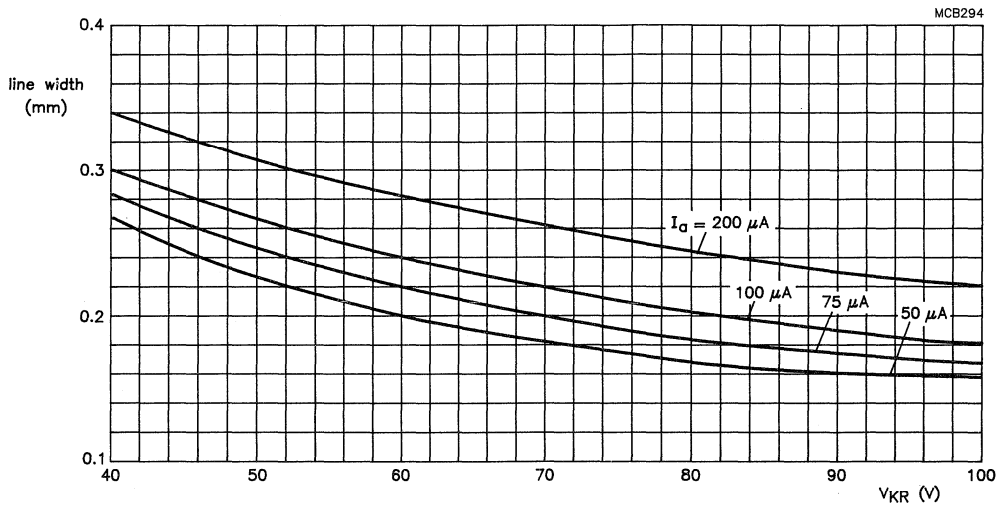

Fig.6 15 inch tube; 110° deflection angle; $V_a = 17$ kV; raster dimensions 194 mm x 259 mm; 241 active lines at 60 Hz repetition frequency.

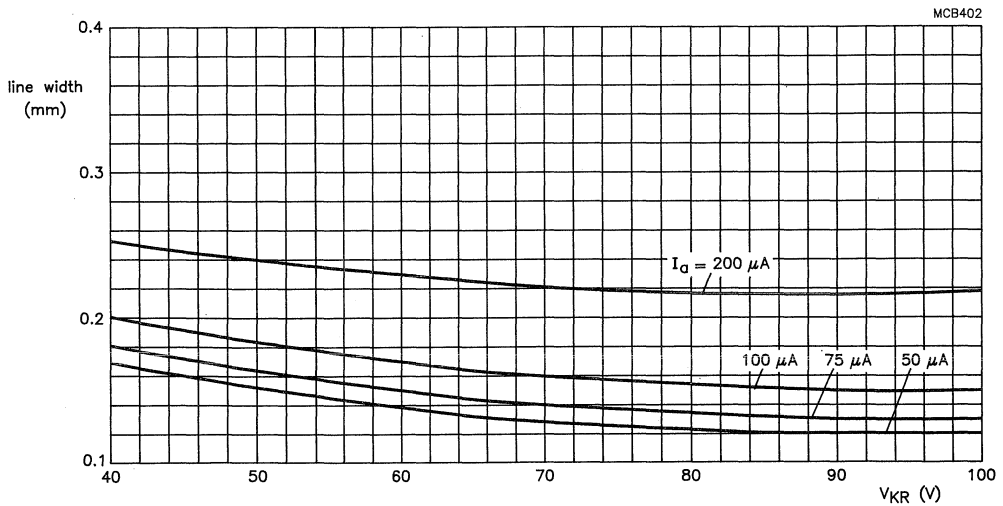

Fig.7 15 inch flat square tube; 110° deflection angle; $V_a = 17$ kV; raster dimensions 194 mm x 259 mm; 241 active lines at 60 Hz repetition frequency.

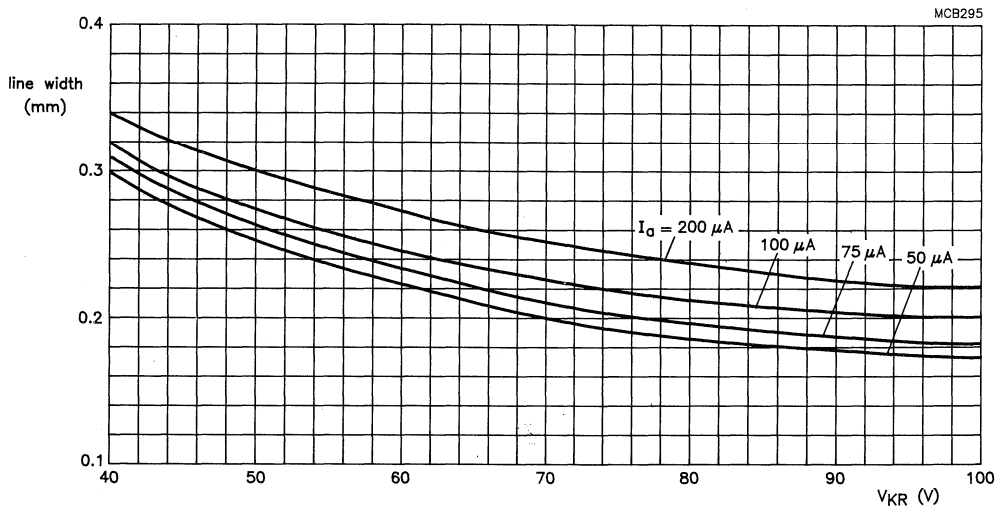

Fig.8 17 inch tube; 110° deflection angle; $V_a = 20$ kV; raster dimensions 228 mm x 304 mm; 241 active lines at 60 Hz repetition frequency.

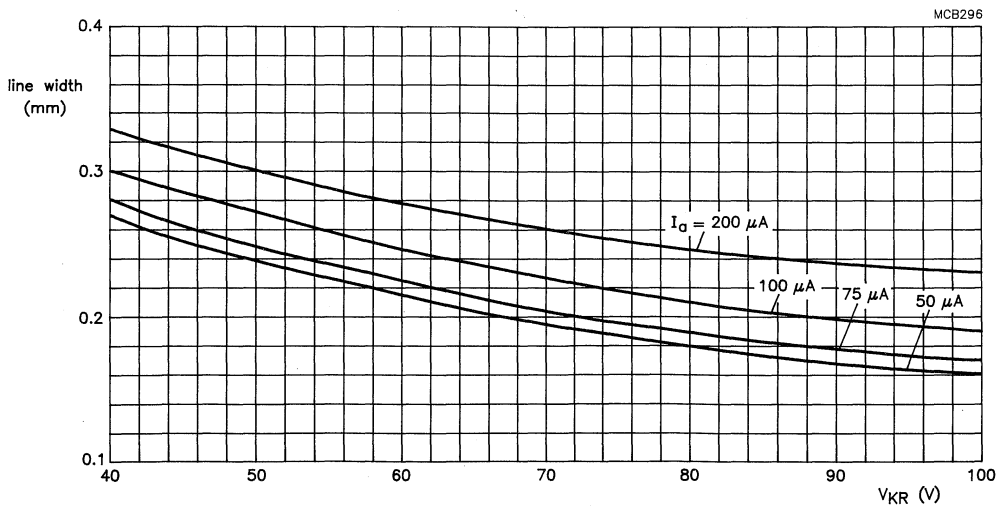

Fig.9 20 inch tube; 110° deflection angle; $V_a = 20$ kV; raster dimensions 261 mm x 348 mm; 241 active lines at 60 Hz repetition frequency.

RESOLUTION CHARACTERISTICS FOR THE HIGH RESOLUTION HIGH CUT-OFF GUN

The following graphs (Figs 1 to 7) represent the line width as a function of the cathode cut-off voltage at a constant anode current (shrinking raster method), at screen centre for different display tubes.

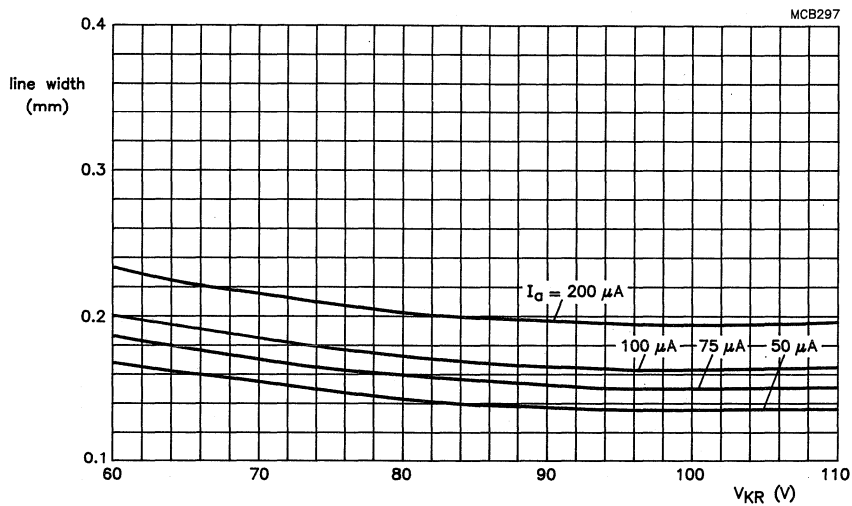

Fig.1 9 inch tube; 90° deflection angle; $V_a = 12$ kV; raster dimensions 126 mm x 166 mm; 241 active lines at 60 Hz repetition frequency.

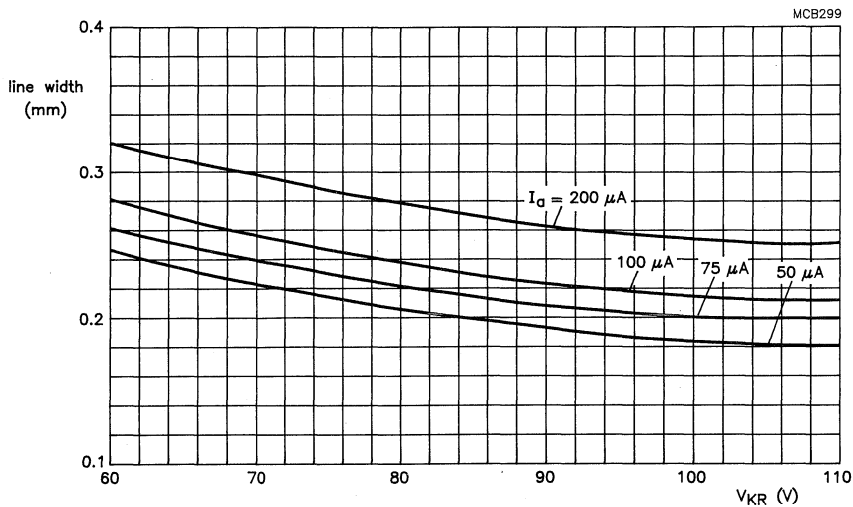

Fig.2 12 inch tube; 90° deflection angle; $V_a = 20$ kV; raster dimensions 162 mm x 216 mm; 241 active lines at 60 Hz repetition frequency.

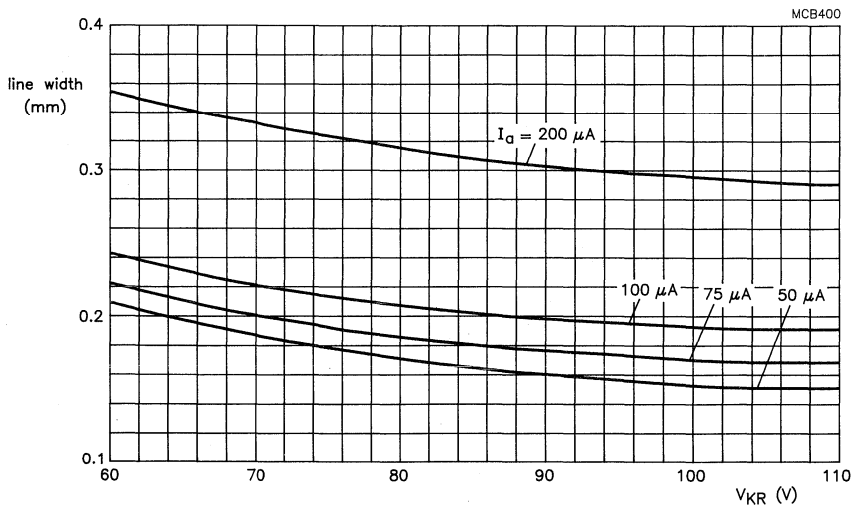

Fig.3 12 inch flat square tubes; 90° deflection angle; $V_a = 12$ kV; raster dimensions 162 mm x 216 mm; 241 active lines at 60 Hz repetition frequency.

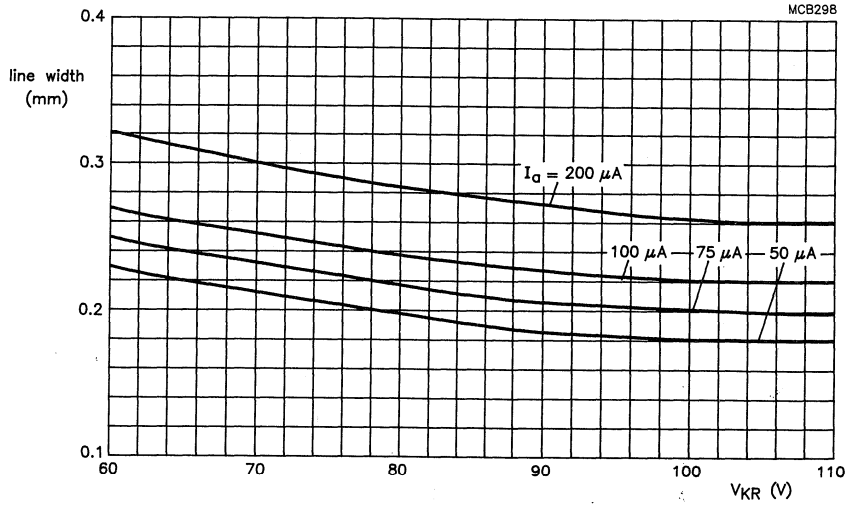

Fig.4 14 inch tube; 90° deflection angle; $V_a = 14$ kV; raster dimensions 178 mm x 237 mm; 241 active lines at 60 Hz repetition frequency.

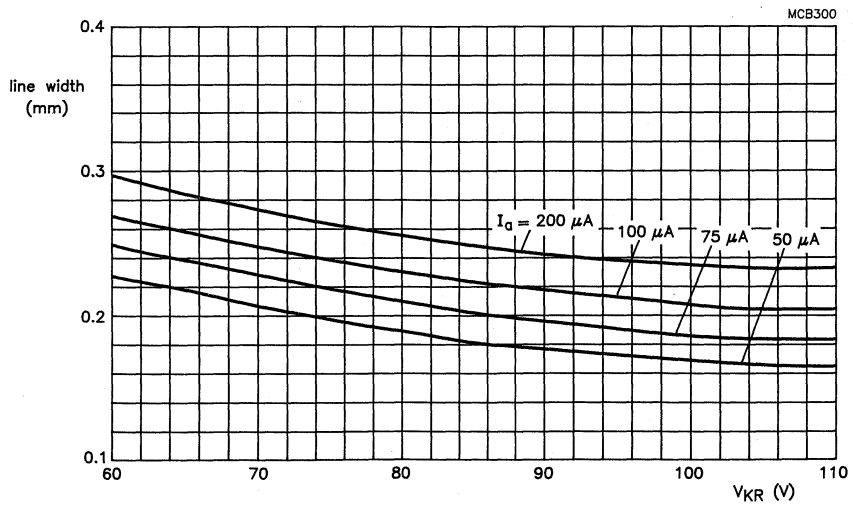

Fig.5 14 inch flat square tube; 90° deflection angle; $V_a = 17$ kV; raster dimensions 178 mm x 237 mm; 241 active lines at 60 Hz repetition frequency.

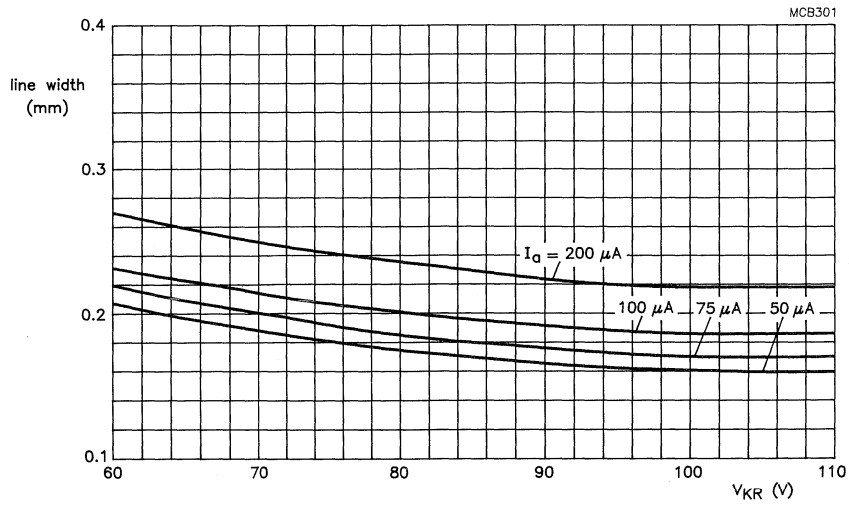

Fig.6 15 inch tube; 110° deflection angle; $V_a = 17$ kV; raster dimensions 194 mm x 259 mm; 241 active lines at 60 Hz repetition frequency.

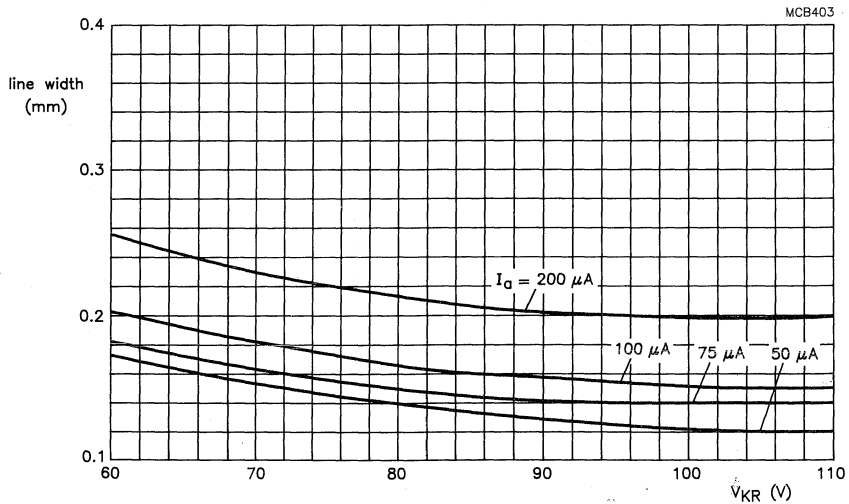

Fig.7 15 inch flat square tube; 110° deflection angle; $V_a = 17$ kV; raster dimensions 194 mm x 259 mm; 241 active lines at 60 Hz repetition frequency.

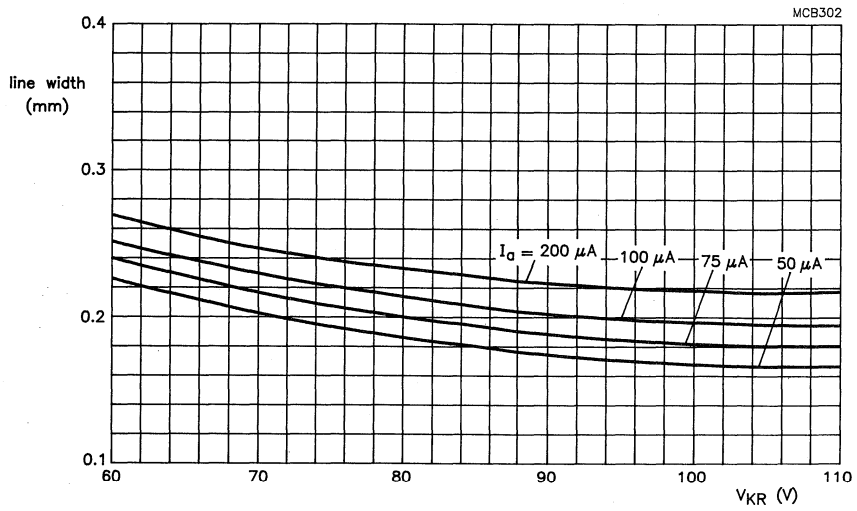

Fig.8 17 inch tube; 110° deflection angle; $V_a = 20$ kV; raster dimensions 228 mm x 304 mm; 241 active lines at 60 Hz repetition frequency.

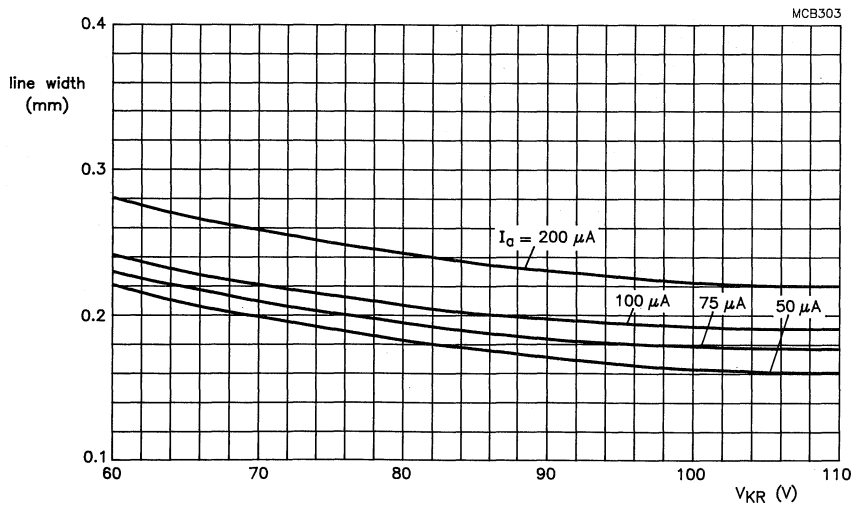

Fig.9 20 inch tube; 110° deflection angle; $V_a = 20$ kV; raster dimensions 261 mm x 318 mm; 241 active lines at 60 Hz repetition frequency.

HIGH RESOLUTION LOW CUT-OFF GUN NARROW NECK

- For high resolution monochrome display tubes
- 90° deflection angle
- 24 cm (9 in), 31 cm (12 in), and 34 cm (14 in) tubes
- 20 mm neck diameter

QUICK REFERENCE DATA

Deflection angle	90°
Face diagonal	24 cm (9 in), 31 cm (12 in) and 34 cm (14 in)
Neck diameter	20 mm
Heating	12 V/130 mA; 12 V/75 mA
Grid 2 voltage	700 mA
Anode voltage	
9 and 12 inch	12 kV
14 inch	14 kV
Resolution (V_{g2} at 700 V)	approx. 1400 lines

For the various phosphors, glass transmission, anti-reflective treatments, reinforcement systems and mechanical tube details relating to the above mentioned tubes, see the relevant section of this book.

ELECTRICAL DATA

Focusing method	electrostatic
Deflection method	magnetic
Direct interelectrode capacitances	
cathode to all other electrodes	max. 5 pF
grid 1 to all other electrodes	max. 8 pF
Heater voltage	12 V
Heater current at 12 V	130 mA/75 mA

RATINGS (absolute maximum system)

Unless otherwise specified, voltage values are positive and measured with respect to Grid 1.

Anode voltage	max. 15 kV
9 inch tube	min. 10 kV
12 inch tube	max. 15 kV
	min. 10 kV
14 inch tube	max. 16 kV
	min. 10 kV
Grid 4 (focusing electrode) voltage	-200 to +1000 V
Grid 2 voltage	max. 1000 V
	min. 400 V
Anode current	
long term average value	max. 130 μ A
peak value	max. 300 μ A
Cathode voltage, positive peak value	max. 400 V
Heater voltage	12 V ^{+5%} _{-10%} *
Cathode to heater voltage	max. 150 V

* For maximum cathode life it is recommended that the heater supply be regulated at 12 V ^{+0%} _{-5%}.

CIRCUIT DESIGN VALUES

Grid 4 current			
positive	max.	25 μ A	
negative	max.	25 μ A	
Grid 2 current			
positive	max.	5 μ A	
negative	max.	5 μ A	
I-rest		5 μ A	see note 1

MAXIMUM CIRCUIT VALUES

Resistance between cathode and heater	max.	1.0 M Ω	
Impedance between cathode and heater	max.	0.1 M Ω	
Grid 1 circuit resistance	max.	1.5 M Ω	
Grid circuit impedance	max.	0.5 M Ω	

TYPICAL OPERATING CONDITIONS

Cathode drive; voltages specified with respect to grid 1

Anode voltage			
9 and 12 inch types		12 kV	
14 inch types		14 kV	
Grid 4 (focusing electrode) voltage		0 to 300 V	see note 2
Grid 2 voltage		700 V	
Cathode cut-off voltage		57 to 87 V	see note 3

Grid drive; voltages specified with respect to cathode

Anode voltage			
9 and 12 inch types		12 kV	
14 inch types		14 kV	
Grid 4 (focusing electrode) voltage		0 to 300 V	see note 2
Grid 2 voltage		700 V	
Grid 1 cut-off voltage		65 to 107 V	see note 3

RESOLUTION

The resolution is approx. 1400 lines. It is measured at the screen centre:

- with shrinking raster method
- at light output = 68.5 cd/m² (20 footlambert), and raster dimensions of 168 mm x 126 mm (9 inch tube), 216 mm x 162 mm (12 inch tube) and 237 mm x 178 mm (14 inch tube)
- at $V_{g2} = 700$ V, and anode voltage (9 and 12 inch types) = 12 kV, (14 inch types) = 14 kV
- with phosphor type W (WW)
- with normal tinted face glass, without anti-glare treatment of screen surface

NOTES

1. Anode current measured at 12 kV (9 and 12 inch types) or 14 kV (14 inch types), 12 V heater voltage with g1, g2 and g4 interconnected to cathode.
2. Measured at screen centre on spot at anode current of 250 μ A (peak), anode voltage of 12 kV for 9 and 12 inch types, 14 kV for 14 inch types and a grid 2 voltage of 700 V.
Dynamic focus (only for optimization): typical correction for a video field of:

H x V = 168 mm x 126 mm (9 inch tube)	} line parabola 100 V, field parabola 100 V
H x V = 216 mm x 162 mm (12 inch tube)	
H x V = 237 mm x 178 mm (14 inch tube)	

3. Visual extinction of focused raster.

For anode current as a function of grid 1 voltage and as a function of cathode voltage, see Figs 1 and 2.

For limits of cut-off voltage as a function of grid 2 voltage, see Figs 3 and 4.

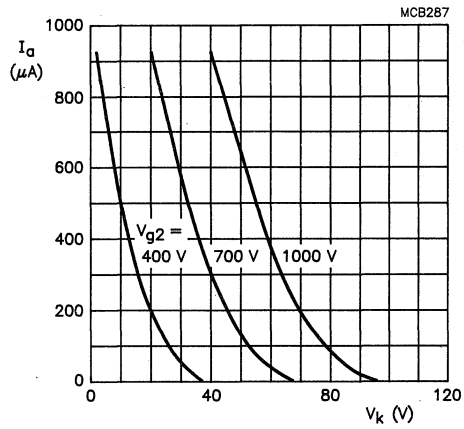

Fig. 1 Anode current as a function of cathode voltage. Cathode drive; $V_{a,g3,g5} = (n) \text{ kV}^*$.

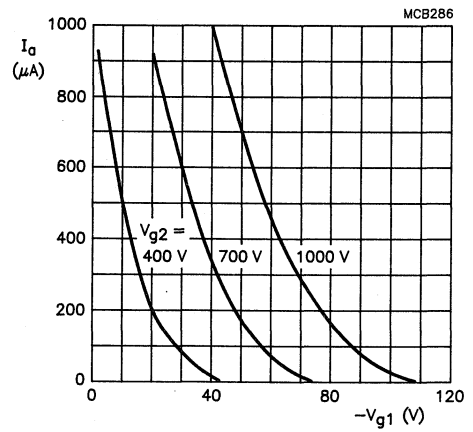

Fig. 2 Anode current as a function of grid 1 voltage. Grid drive; $V_{a,g3,g5} = (n) \text{ kV}^*$.

* (n) = 12 kV for 9 and 12 inch types
 14 kV for 14 inch types
 17 kV for 15 inch (110°) types
 20 kV for 17 and 20 inch types

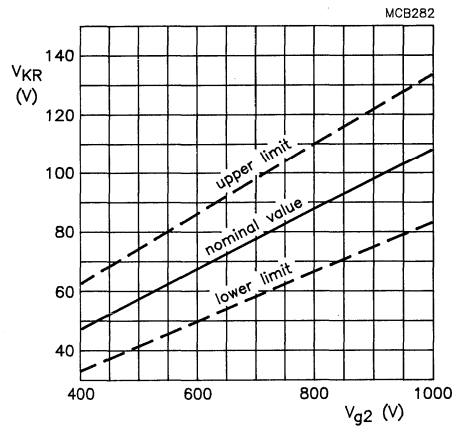

Fig. 3 Limits of cathode cut-off voltage as a function of grid 2 voltage. Cathode drive; $V_{a,g3,g5} = (n) \text{ kV}^*$.

$$\frac{\Delta V_{KR}}{\Delta V_{a,g3,g5}} = 0.15 \times 10^{-3}$$

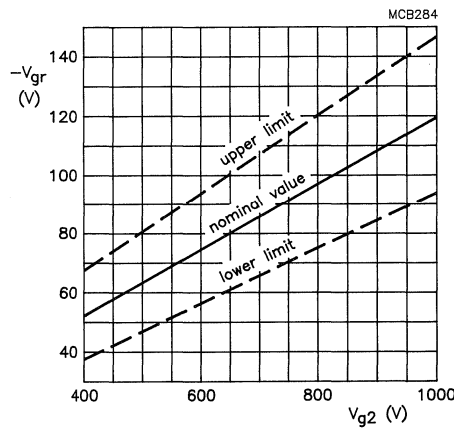

Fig. 4 Limits of grid 1 cut-off voltage as a function of grid 2 voltage. Grid drive; $V_{a,g3,g5} = (n) \text{ kV}^*$.

$$\frac{\Delta V_{GR}}{\Delta V_{a,g3,g5}} = 0.15 \times 10^{-3}$$

* (n) = 12 kV for 9 and 12 inch types
 14 kV for 14 inch types
 17 kV for 15 inch (110⁰) types
 20 kV for 17 and 20 inch types

HIGH RESOLUTION LOW CUT-OFF GUN WIDE NECK

- For high resolution monochrome display tubes
- 110° deflection angle
- 38 cm (15 in), 44 cm (17 in) and 50 cm (20 in) tubes
- 28.6 mm neck diameter

QUICK REFERENCE DATA

Deflection angle	110°
Face diagonal	38 cm (15 in), 44 cm (17 in), 50 cm (20 in)
Neck diameter	28.6 mm
Heating	6.3 V/240 mA; 12 V/130 mA
Grid 2 voltage	550 V
Anode voltage	
15 inch	17 kV
17 and 20 inch	20 kV
Resolution 15 and 17 inch types (V_{g2} at 700 V)	approx. 1600 lines
20 inch types (V_{g2} at 700 V)	approx. 1500 lines

For the various phosphors, glass transmission, anti-reflective treatments, reinforcement systems and mechanical tube details relating to the above mentioned tubes, see the relevant section of this book.

GENERAL

ELECTRICAL DATA

Focusing method	electrostatic
Deflection method	magnetic
Direct interelectrode capacitances	
cathode to all other electrodes	max. 5 pF
grid 1 to all other electrodes	max. 8 pF
Heater voltage	6.3/12 V
Heater current at nominal heater voltage	130/240 mA

RATINGS (absolute maximum system)

Unless otherwise specified, voltage values are positive and measured with respect to Grid 1.

Anode voltage		max.	19 kV
15 inch tube		min.	13 kV
17 inch tube		max.	21 kV
		min.	15 kV
20 inch tube		max.	23 kV
		min.	16 kV
Grid 4 (focusing electrode) voltage			-200 to +1000 V
Grid 2 voltage		max.	1000 V
		min.	400 V
Anode current			
long term average value		max.	100 μ A
peak value		max.	300 μ A
Cathode voltage, positive peak value		max.	400 V
Heater voltage			nominal ^{+5%} *
			-10%
Cathode to heater voltage		max.	150 V

* For maximum cathode life it is recommended that the heater supply be regulated at nominal ^{+0%} _{-5%}.

CIRCUIT DESIGN VALUES

Grid 4 current			
positive	max.	25 μ A	
negative	max.	25 μ A	
Grid 2 current			
positive	max.	5 μ A	
negative	max.	5 μ A	
I-rest		5 μ A	see note 1

MAXIMUM CIRCUIT VALUES

Resistance between cathode and heater	max.	1.0 $M\Omega$
Impedance between cathode and heater	max.	0.1 $M\Omega$
Grid 1 circuit resistance	max.	1.5 $M\Omega$
Grid circuit impedance	max.	0.5 $M\Omega$

TYPICAL OPERATING CONDITIONS

Cathode drive; voltages specified with respect to grid 1

Anode voltage		
15 inch types		17 kV
17 and 20 inch types		20 kV
Grid 4 (focusing electrode) voltage		0 to 400 V
		see note 2
Grid 2 voltage		550 V
Cathode cut-off voltage		72 to 112 V
		see note 3

Grid drive; voltages specified with respect to cathode

Anode voltage		
12 and 15 inch types		17 kV
17 and 20 inch types		20 kV
Grid 4 (focusing electrode) voltage		0 to 400 V
		see note 2
Grid 2 voltage		700 V
Grid 1 cut-off voltage		84 to 126 V
		see note 3

RESOLUTION

The resolution is approx. 1600 and 1500 lines respectively. It is measured at the screen centre:

- with shrinking raster method
- at light output = 68.5 cd/m² (20 footlambert), normal tinted face glass and raster dimensions of 259 mm x 194 mm (15 inch tube)
304 mm x 228 mm (17 inch tube), 348 mm x 261 mm (20 inch tube) and dark tinted face glass and raster dimensions of 267 mm x 200 mm (15 inch FS tube)
- at $V_{g2} = 700$ V, and anode voltage of 17 kV for 15 inch type, and 20 kV for 17 and 20 inch types
- with phosphor type W (WW)
- without anti-glare treatment of screen surface

NOTES

1. Anode current measured at 17 kV (15 inch type) or 20 kV (17 and 20 inch types), nominal heater voltage with g1, g2 and g4 interconnected to cathode.
2. Measured at screen centre on spot at anode current of 250 μ A (peak), anode voltage of 17 kV for 15 inch type, 20 kV for 17 and 20 inch types, and a grid 2 voltage of 700 V.
Dynamic focus (only for optimization): typical corrections are listed in the table below:

Table 1 Dynamic focus

tube type	raster scan (mm)	format	line parabola (V)	field parabola (V)
15 inch	259 x 194	landscape	275	100
15 inch	194 x 259	portrait	125	225
15 inch FS	267 x 200	landscape	300	100
15 inch FS	200 x 267	portrait	125	250
17 inch	304 x 228	—	275	100
20 inch	348 x 261	—	275	100

3. Visual extinction of focused raster.

For anode current as a function of grid 1 voltage and as a function of cathode voltage, see Figs. 1 and 2.

For limits of cut-off voltage as a function of grid 2 voltage, see Figs. 3 and 4.

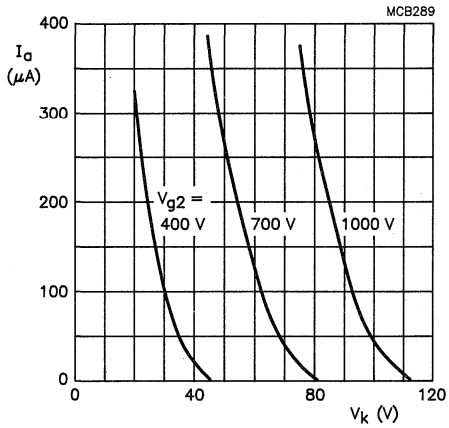

Fig. 1 Anode current as a function of cathode voltage. Cathode drive; $V_{a,g3,g5} = (n) \text{ kV}^*$.

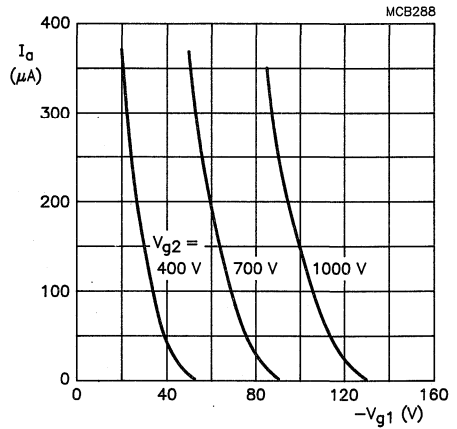

Fig. 2 Anode current as a function of grid 1 voltage. Grid drive; $V_{a,g3,g5} = (n) \text{ kV}^*$.

* (n) = 12 kV for 9 and 12 inch types
 14 kV for 14 inch types
 17 kV for 15 inch (110°) types
 20 kV for 17 and 20 inch types

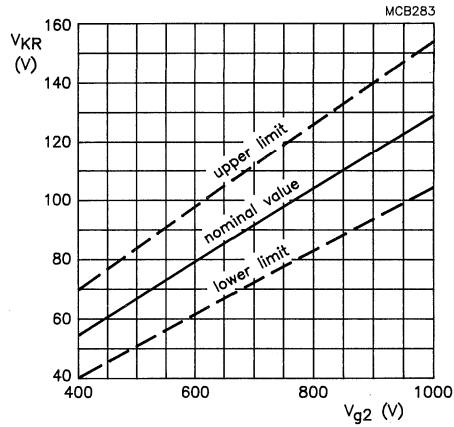

Fig. 3 Limits of cathode cut-off voltage as a function of grid 2 voltage. Cathode drive; $V_{a,g3,g5} = (n) \text{ kV}^*$.

$$\frac{\Delta V_{KR}}{\Delta V_{a,g3,g5}} = 0.15 \times 10^{-3}$$

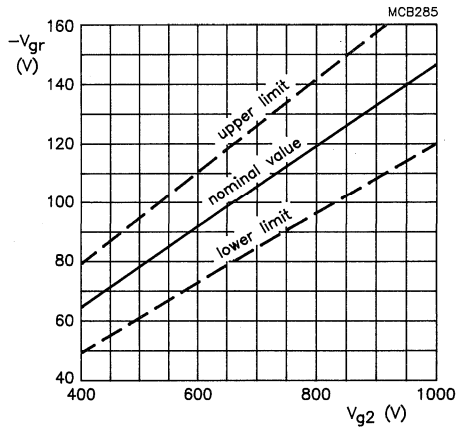

Fig. 4 Limits of grid 1 cut-off voltage as a function of grid 2 voltage. Grid drive; $V_{a,g3,g5} = (n) \text{ kV}^*$.

$$\frac{\Delta V_{GR}}{\Delta V_{a,g3,g5}} = 0.15 \times 10^{-3}$$

* (n) = 12 kV for 9 and 12 inch types
 14 kV for 14 inch types
 17 kV for 15 inch (110⁰) types
 20 kV for 17 and 20 inch types

HIGH RESOLUTION HIGH CUT-OFF GUN NARROW NECK

- For high resolution monochrome display tubes
- 90° deflection angle
- 24 cm (9 in), 31 cm (12 in), and 34 cm (14 in) tubes
- 20 mm neck diameter

QUICK REFERENCE DATA

Deflection angle	90°
Face diagonal	24 cm (9 in), 31 cm (12 in) and 34 cm (14 in)
Neck diameter	20 mm
Heating	12 V/130 mA
Grid 2 voltage	550 V
Anode voltage	
9 and 12 inch	12 kV
14 inch	14 kV
Resolution (V_{g2} at 700 V)	approx. 1400 lines

For the various phosphors, glass transmission, anti-reflective treatments, reinforcement systems and mechanical tube details relating to the above mentioned tubes, see the relevant section of this book.

GENERAL

ELECTRICAL DATA

Focusing method	electrostatic
Deflection method	magnetic
Direct interelectrode capacitances	
cathode to all other electrodes	max. 5 pF
grid 1 to all other electrodes	max. 8 pF
Heater voltage	12 V
Heater current at 12 V	130 mA

RATINGS (absolute maximum system)

Unless otherwise specified, voltage values are positive and measured with respect to Grid 1.

Anode voltage	max. 15 kV
9 inch tube	min. 9.5 kV
12 inch tube	max. 15 kV
	min. 10 kV
14 inch tube	max. 16 kV
	min. 10 kV
Grid 4 (focusing electrode) voltage	-200 to +1000 V
Grid 2 voltage	max. 700 V
	min. 400 V
Anode current	
long term average value	max. 100 μ A
peak value	max. 300 μ A
Cathode voltage, positive peak value	max. 400 V
Heater voltage	12 V $\begin{matrix} +5\% \\ -10\% \end{matrix}$ *
Cathode to heater voltage	max. 150 V

* For maximum cathode life it is recommended that the heater supply be regulated at 12 V $\begin{matrix} +0\% \\ -5\% \end{matrix}$.

CIRCUIT DESIGN VALUES

Grid 4 current			
positive	max.	25 μ A	
negative	max.	25 μ A	
Grid 2 current			
positive	max.	5 μ A	
negative	max.	5 μ A	
I-rest		5 μ A	see note 1

MAXIMUM CIRCUIT VALUES

Resistance between cathode and heater	max.	1.0 M Ω	
Impedance between cathode and heater	max.	0.1 M Ω	
Grid 1 circuit resistance	max.	1.5 M Ω	
Grid circuit impedance	max.	0.5 M Ω	

TYPICAL OPERATING CONDITIONS

Cathode drive; voltages specified with respect to grid 1

Anode voltage			
9 and 12 inch types		12 kV	
14 inch types		14 kV	
Grid 4 (focusing electrode) voltage		0 to 300 V	see note 2
Grid 2 voltage		550 V	
Cathode cut-off voltage		65 to 105 V	see note 3

Grid drive; voltages specified with respect to cathode

Anode voltage			
9 and 12 inch types		12 kV	
14 inch types		14 kV	
Grid 4 (focusing electrode) voltage		0 to 300 V	see note 2
Grid 2 voltage		550 V	
Grid 1 cut-off voltage		73 to 127 V	see note 3

RESOLUTION

The resolution is approx. 1400 lines. It is measured at the screen centre:

- with shrinking raster method
- at light output = 68.5 cd/m² (20 footlambert), and raster dimensions of 168 mm x 126 mm (9 inch tube), 216 mm x 162 mm (12 inch tube) and 237 mm x 178 mm (14 inch tube)
- at $V_{g2} = 700$ V, and anode voltage (9 and 12 inch types) = 12 kV, (14 inch types) = 14 kV
- with phosphor type W (WW)
- with normal tinted face glass, without anti-glare treatment of screen surface

NOTES

1. Anode current measured at 12 kV (9 and 12 inch types) or 14 kV (14 inch types), 12 V heater voltage with g1, g2 and g4 interconnected to cathode.
2. Measured at screen centre on spot at anode current of 250 μ A (peak), anode voltage of 12 kV for 9 and 12 inch types, 14 kV for 14 inch types and a grid 2 voltage of 550 V.
Dynamic focus (only for optimization): typical correction for a video field of:

H x V = 168 mm x 126 mm (9 inch tube)

H x V = 216 mm x 162 mm (12 inch tube)

H x V = 237 mm x 178 mm (14 inch tube)

} line parabola 100 V, field parabola 100 V

3. Visual extinction of focused raster.

For anode current as a function of grid 1 voltage and as a function of cathode voltage, see Figs 1 and 2.

For limits of cut-off voltage as a function of grid 2 voltage, see Figs 3 and 4.

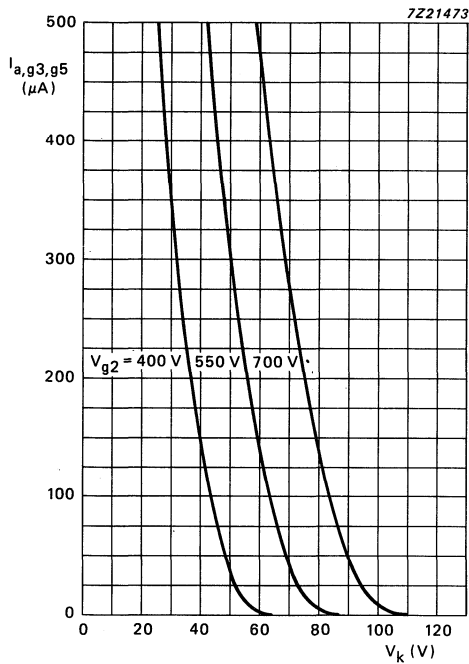

Fig. 1 Anode current as a function of cathode voltage. Cathode drive; $V_{a,g3,g5} = (n) kV^*$.

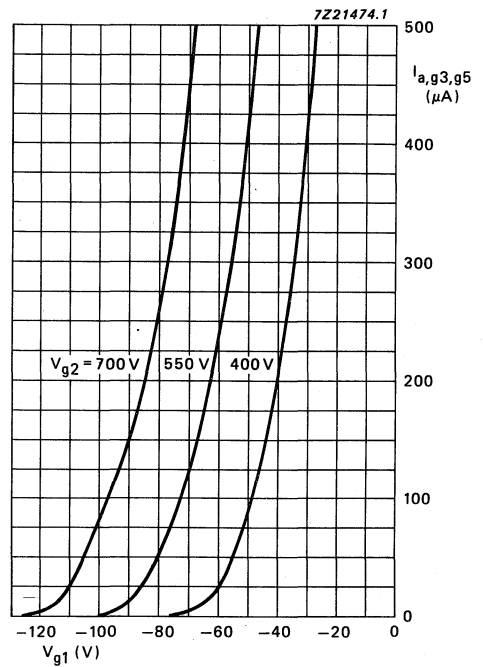

Fig. 2 Anode current as a function of grid 1 voltage. Grid drive; $V_{a,g3,g5} = (n) kV^*$.

* (n) = 12 kV for 9 and 12 inch types
 14 kV for 14 inch types
 17 kV for 15 inch (110°) types
 20 kV for 17 and 20 inch types

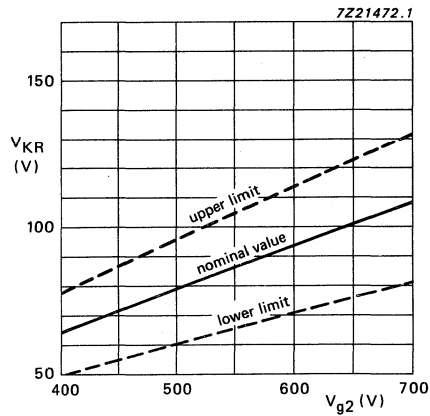

Fig. 3 Limits of cathode cut-off voltage as a function of grid 2 voltage. Cathode drive; $V_{a,g3,g5} = (n) \text{ kV}^*$.

$$\frac{\Delta V_{KR}}{\Delta V_{a,g3,g5}} = 0.15 \times 10^{-3}$$

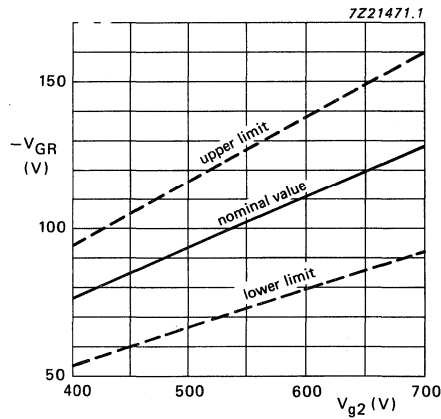

Fig. 4 Limits of grid 1 cut-off voltage as a function of grid 2 voltage. Grid drive; $V_{a,g3,g5} = (n) \text{ kV}^*$.

$$\frac{\Delta V_{GR}}{\Delta V_{a,g3,g5}} = 0.15 \times 10^{-3}$$

* (n) = 12 kV for 9 and 12 inch types
 14 kV for 14 inch types
 17 kV for 15 inch (110⁰) types
 20 kV for 17 and 20 inch types

HIGH RESOLUTION HIGH CUT-OFF GUN WIDE NECK

- For high resolution monochrome display tubes
- 110° deflection angle
- 38 cm (15 in), 44 cm (17 in) and 50 cm (20 in) tubes
- 28.6 mm neck diameter

QUICK REFERENCE DATA

Deflection angle	110°
Face diagonal	38 cm (15 in), 44 cm (17 in), 50 cm (20 in)
Neck diameter	28.6 mm
Heating	6.3 V/240 mA; 12 V/130 mA
Grid 2 voltage	550 V
Anode voltage	
15 inch	17 kV
17 and 20 inch	20 kV
Resolution 15 and 17 inch types (V_{g2} at 700 V)	approx. 1600 lines
20 inch types (V_{g2} at 700 V)	approx. 1500 lines

For the various phosphors, glass transmission, anti-reflective treatments, reinforcement systems and mechanical tube details relating to the above mentioned tubes, see the relevant section of this book.

GENERAL

ELECTRICAL DATA

Focusing method	electrostatic
Deflection method	magnetic
Direct interelectrode capacitances	
cathode to all other electrodes	max. 5 pF
grid 1 to all other electrodes	max. 8 pF
Heater voltage	6.3/12 V
Heater current at nominal heater voltage	240/130 mA

RATINGS (absolute maximum system)

Unless otherwise specified, voltage values are positive and measured with respect to Grid 1.

Anode voltage	
15 inch tube	max. 19 kV min. 13 kV
17 inch tube	max. 21 kV min. 15 kV
20 inch tube	max. 23 kV min. 16 kV
Grid 4 (focusing electrode) voltage	-200 to +1000 V
Grid 2 voltage	max. 700 V min. 400 V
Anode current	
long term average value	max. 100 μ A
peak value	max. 300 μ A
Cathode voltage, positive peak value	max. 400 V
Heater voltage	nominal $\begin{matrix} +5\% \\ -10\% \end{matrix}$ *
Cathode to heater voltage	max. 150 V

* For maximum cathode life it is recommended that the heater supply be regulated at nominal $\begin{matrix} +0\% \\ -5\% \end{matrix}$.

CIRCUIT DESIGN VALUES

Grid 4 current			
positive	max.	25 μ A	
negative	max.	25 μ A	
Grid 2 current			
positive	max.	5 μ A	
negative	max.	5 μ A	
I-rest		5 μ A	see note 1

MAXIMUM CIRCUIT VALUES

Resistance between cathode and heater	max.	1.0 $M\Omega$
Impedance between cathode and heater	max.	0.1 $M\Omega$
Grid 1 circuit resistance	max.	1.5 $M\Omega$
Grid circuit impedance	max.	0.5 $M\Omega$

TYPICAL OPERATING CONDITIONS

Cathode drive; voltages specified with respect to grid 1

Anode voltage		
15 inch types		17 kV
17 and 20 inch types		20 kV
Grid 4 (focusing electrode) voltage	0 to 300 V	see note 2
Grid 2 voltage	550 V	
Cathode cut-off voltage	65 to 105 V	see note 3

Grid drive; voltages specified with respect to cathode

Anode voltage		
12 and 15 inch types		17 kV
17 and 20 inch types		20 kV
Grid 4 (focusing electrode) voltage	0 to 300 V	see note 2
Grid 2 voltage	550 V	
Grid 1 cut-off voltage	73 to 127 V	see note 3

RESOLUTION

The resolution is approx. 1600 and 1500 lines respectively. It is measured at the screen centre:

- with shrinking raster method
- at light output = 68.5 cd/m² (20 footlambert), normal tinted face glass and raster dimensions of 259 mm x 194 mm (15 inch tube)
304 mm x 228 mm (17 inch tube), 348 mm x 261 mm (20 inch tube) and dark tinted face glass and raster dimensions of 267 mm x 200 mm (15 inch FS tube)
- at $V_{g2} = 700$ V, and anode voltage of 17 kV for 15 inch type, and 20 kV for 17 and 20 inch types
- with phosphor type W (WW)
- without anti-glare treatment of screen surface

NOTES

1. Anode current measured at 17 kV (15 inch type) or 20 kV (17 and 20 inch types), nominal heater voltage with g1, g2 and g4 interconnected to cathode.
2. Measured at screen centre on spot at anode current of 250 μ A (peak), anode voltage of 17 kV for 15 inch type, 20 kV for 17 and 20 inch types, and a grid 2 voltage of 550 V.
Dynamic focus (only for optimization): typical corrections are listed in the table below:

Table 1 Dynamic focus

tube type	raster scan (mm)	format	line parabola (V)	field parabola (V)
15 inch	259 x 194	landscape	275	100
15 inch	194 x 259	portrait	125	225
15 inch FS	267 x 200	landscape	300	100
15 inch FS	200 x 267	portrait	125	250
17 inch	304 x 228	—	275	100
20 inch	348 x 261	—	275	100

3. Visual extinction of focused raster.

For anode current as a function of grid 1 voltage and as a function of cathode voltage, see Figs. 1 and 2.

For limits of cut-off voltage as a function of grid 2 voltage, see Figs. 3 and 4.

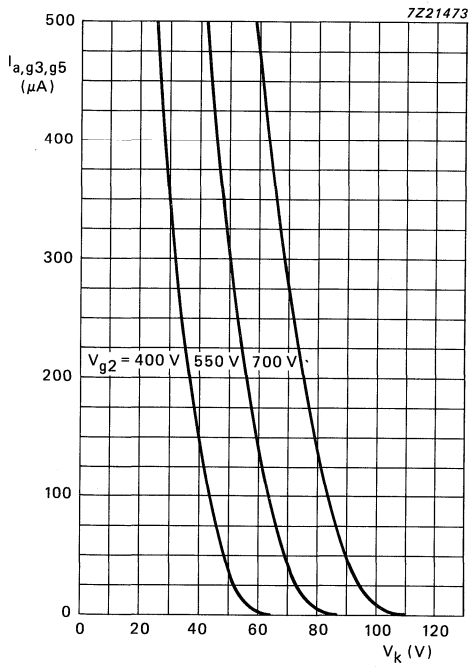

Fig. 1 Anode current as a function of cathode voltage. Cathode drive; $V_{a,g3,g5} = (n)\text{ kV}^*$.

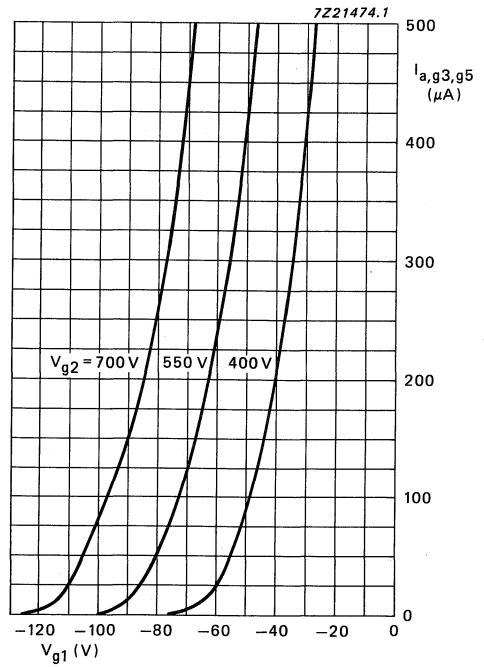

Fig. 2 Anode current as a function of grid 1 voltage. Grid drive; $V_{a,g3,g5} = (n)\text{ kV}^*$.

* (n) = 12 kV for 9 and 12 inch types
 14 kV for 14 inch types
 17 kV for 15 inch (110°) types
 20 kV for 17 and 20 inch types

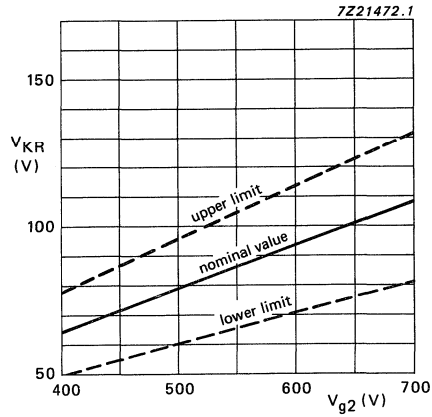

Fig. 3 Limits of cathode cut-off voltage as a function of grid 2 voltage. Cathode drive; $V_{a,g3,g5} = (n) \text{ kV}^*$.

$$\frac{\Delta V_{KR}}{\Delta V_{a,g3,g5}} = 0.15 \times 10^{-3}$$

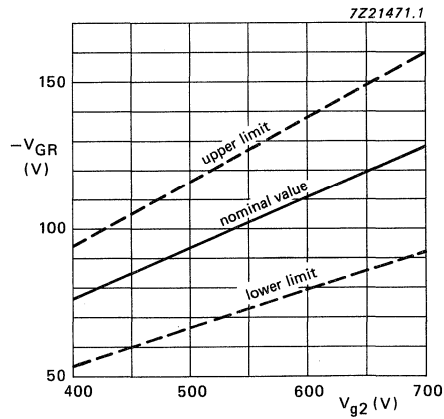

Fig. 4 Limits of grid 1 cut-off voltage as a function of grid 2 voltage. Grid drive; $V_{a,g3,g5} = (n) \text{ kV}^*$.

$$\frac{\Delta V_{GR}}{\Delta V_{a,g3,g5}} = 0.15 \times 10^{-3}$$

* (n) = 12 kV for 9 and 12 inch types
 14 kV for 14 inch types
 17 kV for 15 inch (110⁰) types
 20 kV for 17 and 20 inch types

REFERENCE LINE GAUGES

REFERENCE LINE GAUGE C (JEDEC 126) (IEC 67-IV-3)

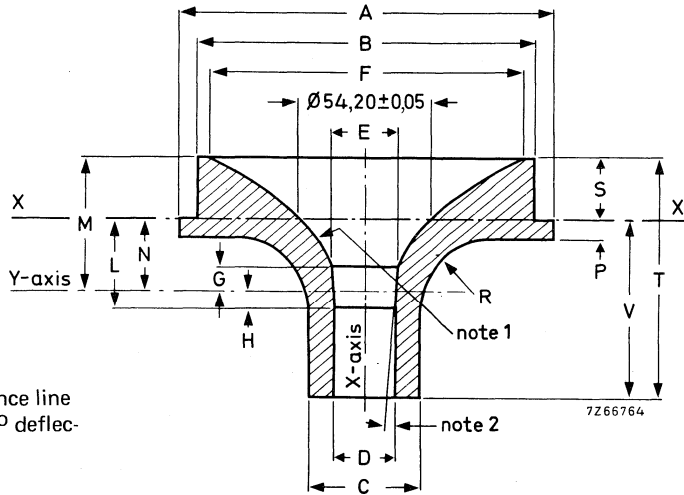

Fig. 1 Reference line gauge for 110° deflection angle.

The millimetre dimensions are derived from the original inch dimensions.

ref.	inches			millimetres			notes
	min.	nom.	max.	min.	nom.	max.	
A	—	5,000	—	—	127,00	—	—
B	—	4,500	—	—	114,30	—	—
C	—	2,000	—	—	50,80	—	—
D	1,168	1,168	1,171	29,668	29,668	29,743	—
E	1,241	1,242	1,243	31,522	31,547	31,572	—
F	4,248	4,250	4,252	107,900	107,950	108,000	—
G	—	0,279	—	—	7,09	—	2
H	—	0,250	—	—	6,35	—	—
L	1,165	1,170	1,175	29,60	29,72	29,84	2
M	—	1,634	—	—	41,50	—	—
N	—	0,920	—	—	23,37	—	1
P	—	0,250	—	—	6,35	—	—
R	—	1,000r	—	—	25,40r	—	—
S	0,712	0,714	0,716	18,085	18,136	18,186	—
T	—	3,214	—	—	81,64	—	—
V	2,490	2,500	2,510	63,25	63,50	63,75	—

Notes

- $y = 0,58 x^2 + 0,576$ inches ($0,0228 x^2 + 14,630$ mm) 'y' values must be held to $\pm 0,002''$ (0,05 mm).
The Y-axis is 0,920'' (23,368 mm) below the X-X' reference plane.
- $4^\circ \pm 30'$ taper between planes G and L.

REFERENCE LINE GAUGE D (EIA G-197)

Dimensions in mm

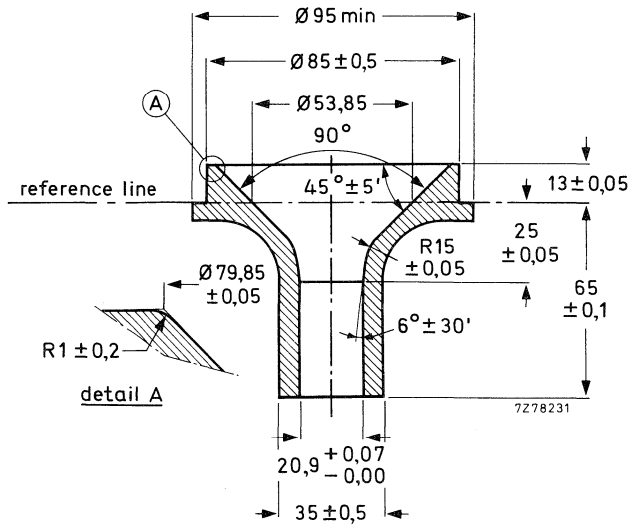

Fig. 2 Reference line gauge for 90° deflection angle.

REFERENCE LINE GAUGE G (JEDEC G148)

Dimensions in mm

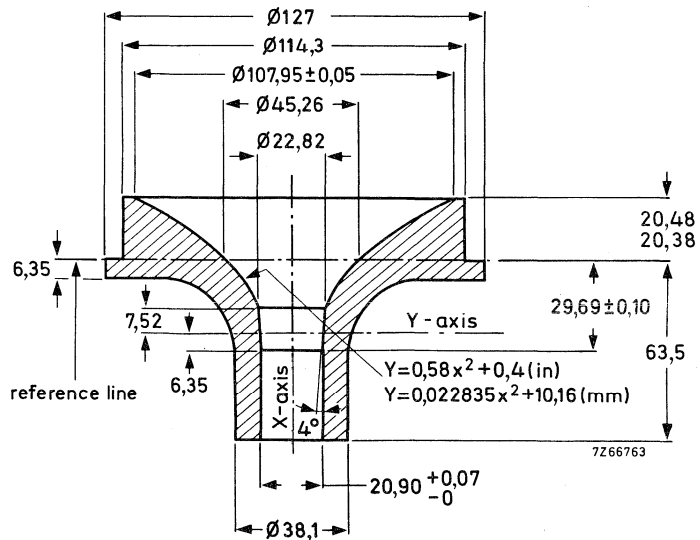

Fig. 3 Reference line gauge for 110° deflection angle.

BASES

SMALL-BUTTON NEO EIGHTAR BASE IEC 67-1-31
JEDEC B7-208

Dimensions in mm

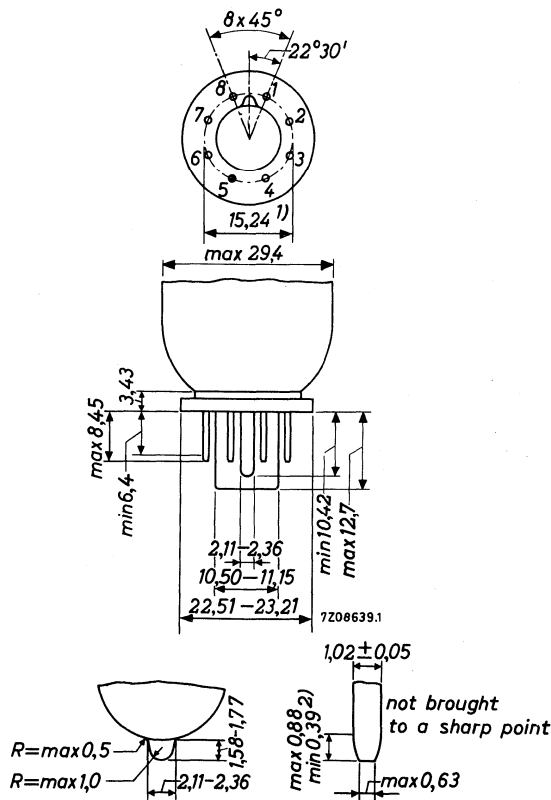

Fig. 1.

Notes

1. Base-pin positions are held to tolerances such that the base will fit a flat-plate gauge having a thickness of 9,53 and eight equally spaced holes of $1,40 \pm 0,01$ diameter located on a $15,24 \pm 0,01$ diameter circle. The gauge is also provided with a centre hole to provide 0,25 diametric clearance for the lug and key. Pin fit in the gauge shall be such that the entire length of pins will, without undue force, pass into and disengage from the gauge.
2. This dimension may vary within the limits shown around the periphery of any individual pin.

7-PIN MINIATURE BASE WITH PUMPING STEM

Dimensions in mm

Dimensions of this base are within the JEDEC E7-91 dimensions

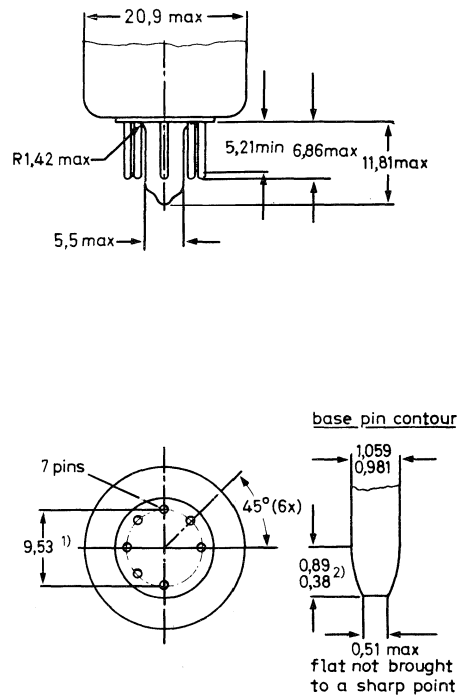

Fig. 2.

Notes

1. Base-pin and pumping stem positions are held to tolerances such that entire length of pins and stem will without undue force pass into and disengage from a flat-plate gauge having a thickness of 6,35 mm and eight holes with diameters of $1,27 \pm 0,013$ mm so located on a $9,525 \pm 0,013$ mm diameter circle that the distance along the chord between any two adjacent hole centres is $3,645 \pm 0,013$ mm and a centre hole of $5,97 + 0,025$ mm being chamfered at the top over 1,52 mm with an angle of 45 degrees.
2. This dimension around the periphery of any individual pin may vary within the limits shown.

MONOCHROME MONITOR TUBES

HIGH RESOLUTION MONOCHROME MONITOR TUBES

- For Data Graphic Displays
- 90° deflection angle
- 24 cm (9 in) face diagonal; rectangular glass
- 20 mm neck diameter
- Integral implosion protection

QUICK REFERENCE DATA

Deflection angle	90°
Face diagonal	24 cm (9 in)
Overall length	max. 227 mm
Neck diameter	20 mm
Heating	12 V/130 mA
Quick heating cathode	with a typical tube a legible picture will appear within 5 s
Grid 2 voltage	700 V
Anode voltage	12 kV
Resolution	approx. 1300 lines

APPLICATION

These high resolution tubes are for alpha-numeric and graphic display applications, such as computer terminals, small business computers, etc.

AVAILABLE VERSIONS

The following versions are available: M24-306, M24-308, M24-310 and M24-328. Differences between the tubes can be found under 'Dimensional data'.

The tubes can be supplied with different phosphors and anti-reflective treatments, see "High resolution monochrome monitor tubes, General".

ELECTRICAL DATA

Focusing method	electrostatic
Deflection method	magnetic
Deflection angles	
diagonal	approx. 90°
horizontal	approx. 82°
vertical	approx. 67°
Direct interelectrode capacitances	
cathode to all other electrodes	max. 5 pF
grid 1 to all other electrodes	max. 7 pF
Capacitance of external conductive coating to anode*	max. 850 pF min. 300 pF
Capacitance of external conductive coating to anode**	max. 750 pF min. 300 pF
Capacitance of anode to implosion protection hardware**	approx. 100 pF
Heater voltage	12 V
Heater current at 12 V	130 mA

OPTICAL DATA

Phosphor type	see "High resolution monochrome monitor tubes, General".
Light transmission at screen centre	
tube with normal tinted face glass	approx. 53%
tube with dark tinted face glass	approx. 42%

RASTER CENTRING

The field intensity perpendicular to the tube axis should be adjustable from 0 to 800 A/m. For optimum overall sharpness it is recommended to centre the raster electrically via the deflection coils.

* Implosion protection hardware connected to external conductive coating.

** Implosion protection hardware not connected to external conductive coating.

MECHANICAL DATA (see also the figures under Dimensions Data)

Overall length	max. 227 mm
Greatest dimensions of tube	
diagonal	248,5 mm
width	216 mm
height	167 mm
Minimum useful screen dimensions (projected)	
diagonal	222,5 mm
horizontal axis	193 mm
vertical axis	145 mm
area	268 cm ²
Implosion protection	T-band
Bulb	EIAJ-JB240AA03 or EIAJ-JB240AA04
Bulb contact designation	IEC 67-III-2, EIA-J1-21
Base designation	EIA E7-91
Basing	7GR
Mass	approx. 1,8 kg

RATINGS (Absolute Maximum System)

Unless otherwise specified voltage values are positive and measured with respect to grid 1.

Anode voltage	max. 15 kV min. 9,5 kV
Grid 4 (focusing electrode) voltage	-200 to + 1000 V
Grid 2 voltage	min. 400 V max. 1000 V
Anode current	
long-term average value	max. 130 μ A
peak value	max. 300 μ A
Cathode voltage, positive peak value	max. 400 V
Heater voltage	12 V +5/-10%
Cathode-to-heater voltage	max. 100 V

* For maximum cathode life it is recommended that the heater supply be regulated at 12 V $\begin{matrix} +0\% \\ -5\% \end{matrix}$

CIRCUIT DESIGN VALUES

Grid 4 current		
positive	max.	25 μ A
negative	max.	25 μ A
Grid 2 current		
positive	max.	5 μ A
negative	max.	5 μ A

MAXIMUM CIRCUIT VALUES

Resistance between cathode and heater	max.	1,0 M Ω
Impedance between cathode and heater	max.	0,1 M Ω
Grid 1 circuit resistance	max.	1,5 M Ω
Grid 1 circuit impedance	max.	0,5 M Ω

TYPICAL OPERATING CONDITIONS

Cathode drive; voltages specified with respect to grid 1

Anode voltage	12 kV
Grid 4 (focusing electrode) voltage	0 to 300 V*
Grid 2 voltage	700 V
Cathode cut-off voltage	57 to 97 V**

Grid drive; voltages specified with respect to cathode

Anode voltage	12 kV
Grid 4 (focusing electrode) voltage	0 to 300 V*
Grid 2 voltage	700 V
Grid 1 cut-off voltage	65 to 107 V**

RESOLUTION

The resolution is approx. 1300 lines. It is measured at the screen centre:

- with shrinking raster method,
- at light output 68,5 cd/m² (20 foot lambert) and raster dimensions 168 mm x 126 mm,
- at $V_{g2} = 700$ V and anode voltage = 12 kV,
- with phosphor type W (WW),
- with normal tinted face glass, without anti-glare treatment of screen surface.

X-RADIATION CHARACTERISTIC

X-radiation emitted will not exceed 0,5 mR/h throughout the useful life of the tube, when operated within the given ratings.

* Measured at screen centre on spot at anode current = 250 μ A (peak), anode voltage = 12 kV, grid 2 voltage = 700 V.

Dynamic focus (only for optimization): Typical correction for a video field of H x V = 168 mm x 126 mm:
line parabola 200 V;
field parabola 100 V.

** Visual extinction of focused raster.

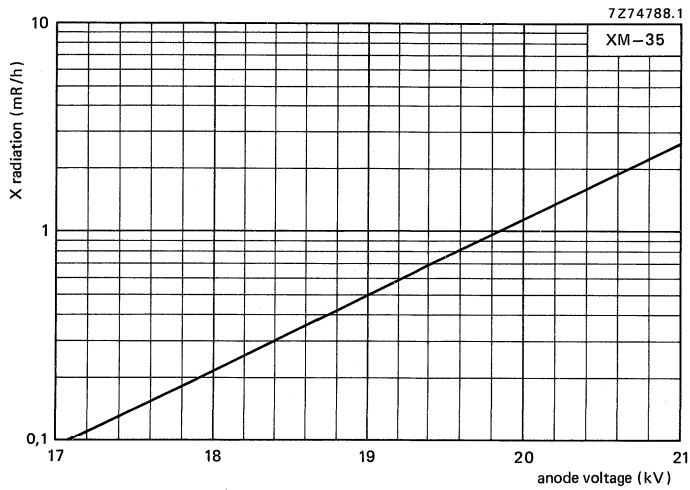

Fig. 1 X-radiation limit curve according to JEDEC94, at a constant anode current of 250 μA , measured according to TEPAC103A.

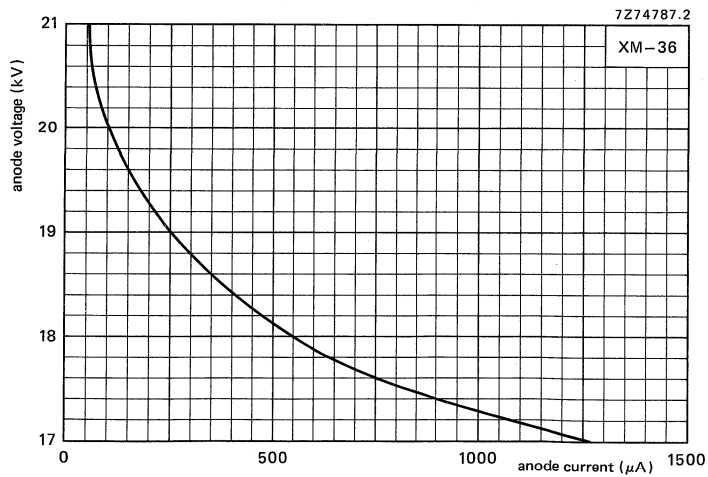

Fig. 2 0,5 mR/h isoexposure-rate limit curve, according to JEDEC94, measured according to TEPAC103A.

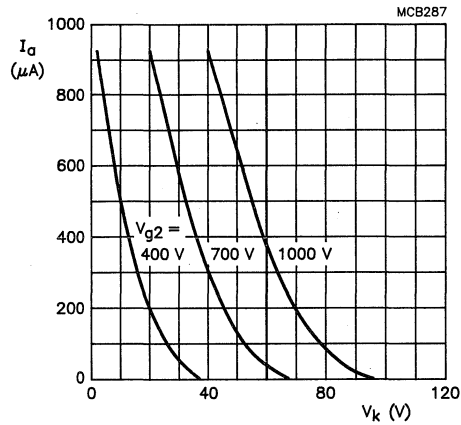

Fig. 3 Anode current as a function of cathode voltage.
Cathode drive; $V_{a,g3,g5} = 12$ kV.

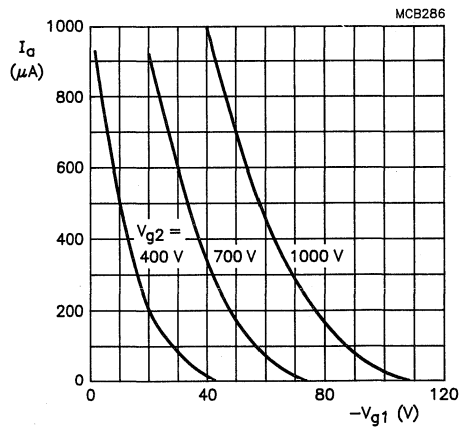

Fig. 4 Anode current as a function of grid 1 voltage.
Grid drive; $V_{a,g3,g5} = 12$ kV.

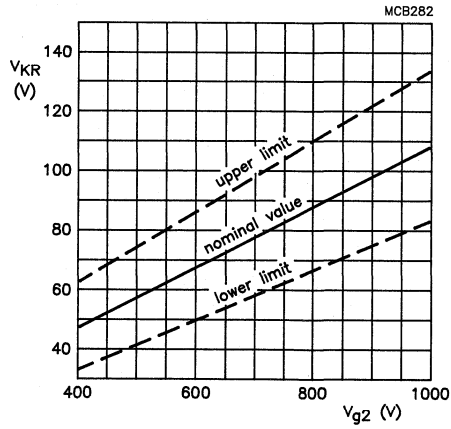

Fig. 5 Limits of cathode cut-off voltage as a function of grid 2 voltage.
Cathode drive; $V_{a,g3,g5} = 12$ kV.

$$\frac{\Delta V_{KR}}{\Delta V_{a,g3,g5}} = 0.9 \times 10^{-3}$$

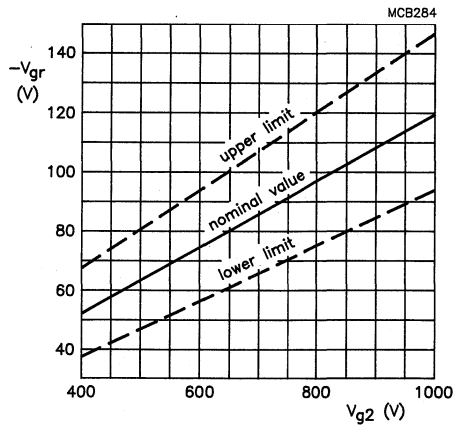

Fig. 6 Limits of grid 1 cut-off voltage as a function of grid 2 voltage.
Grid drive; $V_{a,g3,g5} = 12$ kV.

$$\frac{\Delta V_{GR}}{\Delta V_{a,g3,g5}} = 0.9 \times 10^{-3}$$

DIMENSIONAL DATA

Dimensions in mm

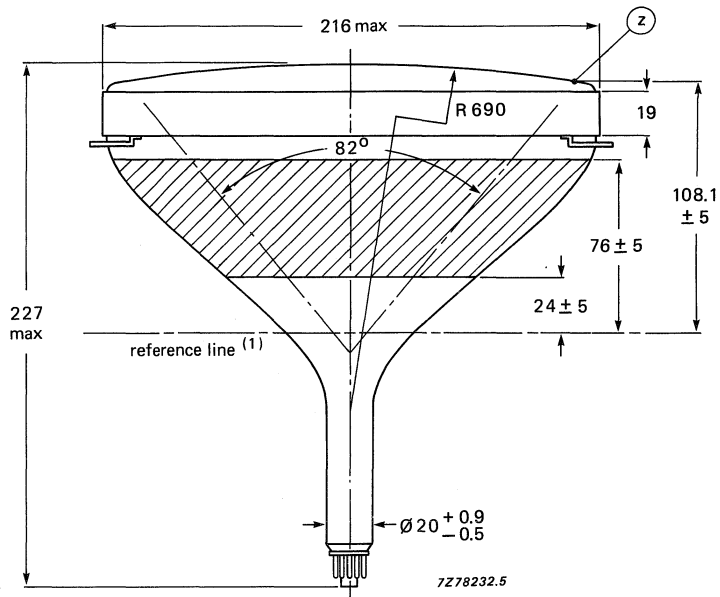

Fig. 7.

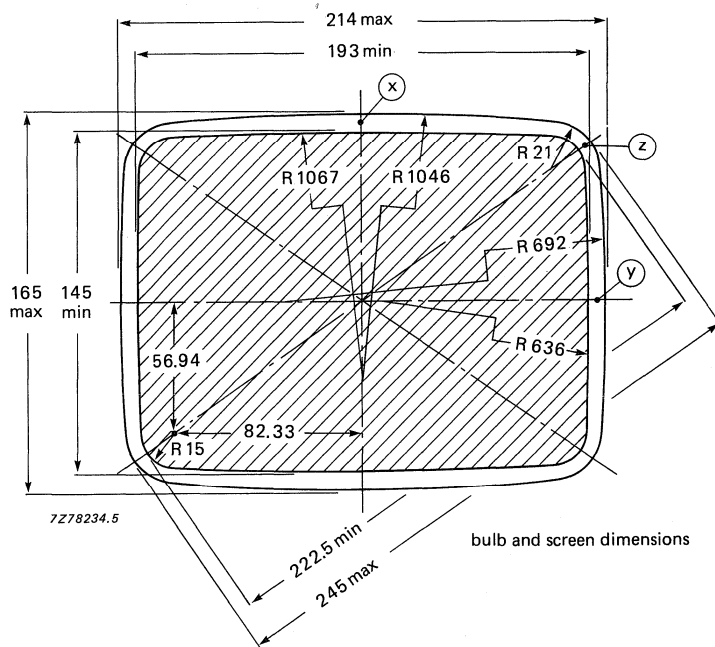

Fig. 8.

(1) The reference line is determined by the plane of the upper edge of reference line gauge D when the gauge is resting on the cone.

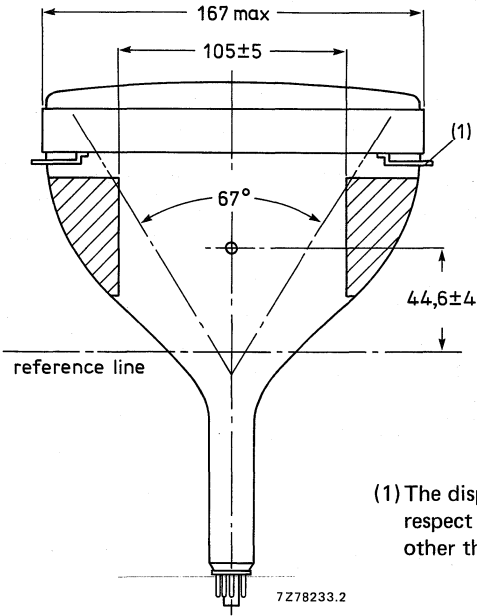

Fig. 9.

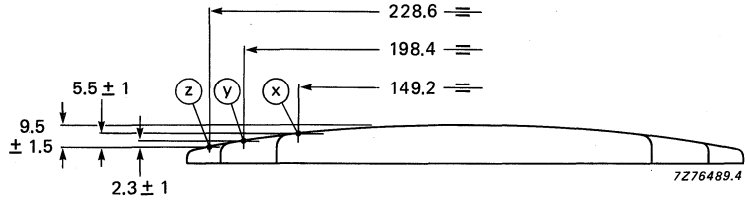

Fig. 10 Screen reference points.

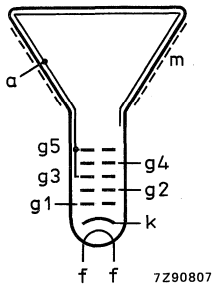

Fig. 11 Electrode configuration.

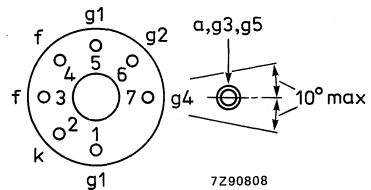

Fig. 12 Pin arrangement.

Front view and lug dimensions of tube M24-306

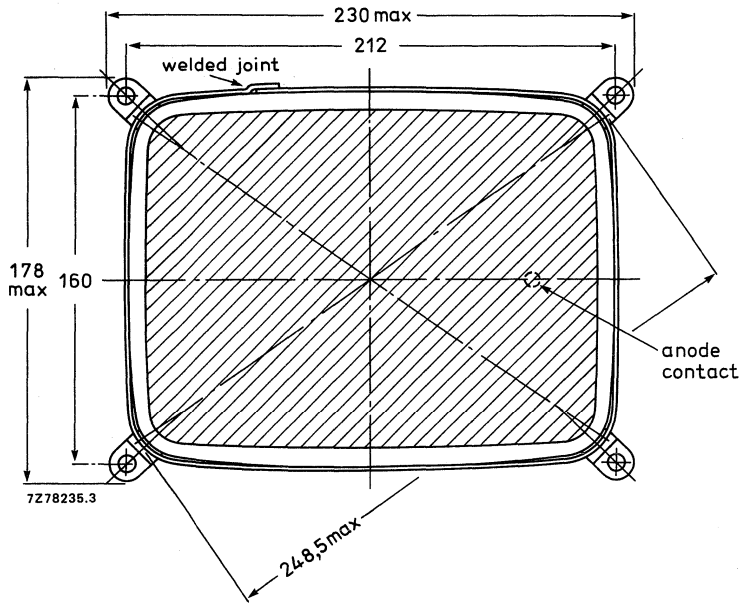

Fig. 13 Tube mounting dimensions; front view.

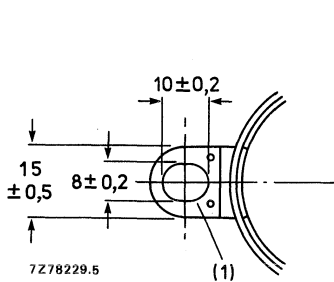

Fig. 14 Lug dimensions.

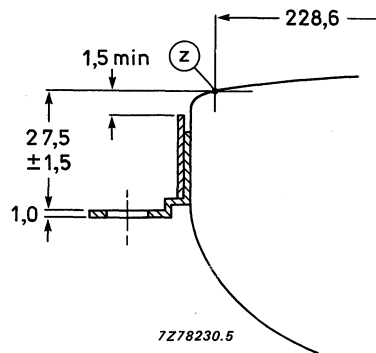

Fig. 15 Lug position.

(1) The position of the mounting screws in the cabinet must be within a circle of 5 mm diameter drawn around the true geometrical positions, i.e. the corners of a rectangle of 212 mm x 160 mm.

Front view and lug dimensions of tube M24-308

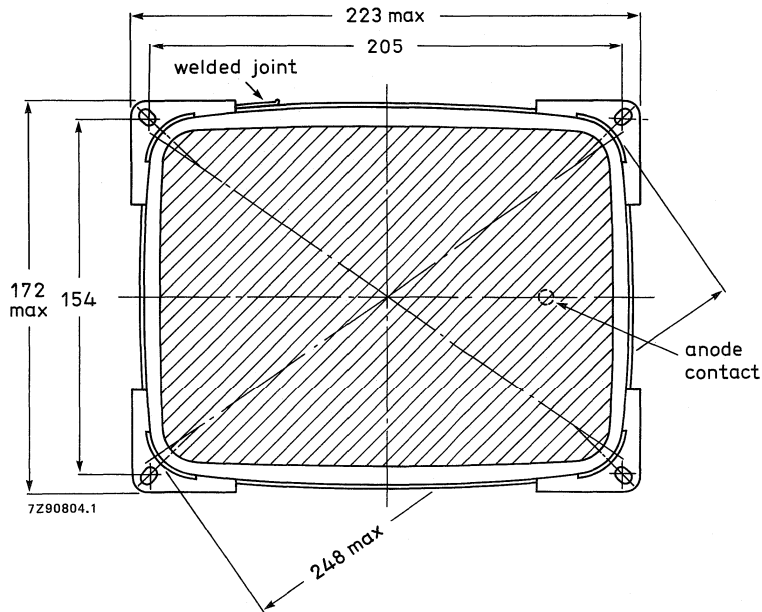

Fig. 16 Tube mounting dimensions; front view.

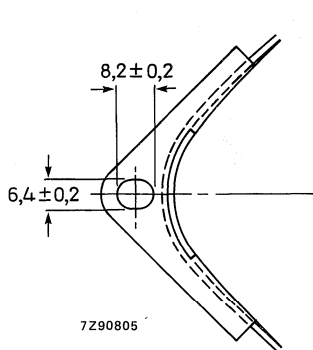

Fig. 17 Lug dimensions.

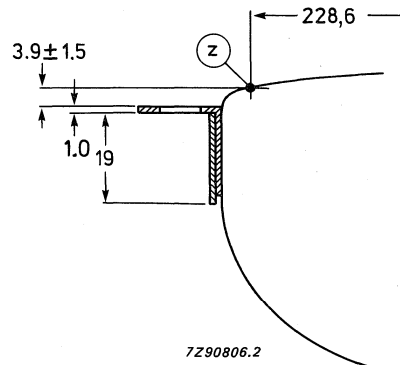

Fig. 18 Lug position.

(1) The position of the mounting screws in the cabinet must be within a circle of 3,4 mm diameter drawn around the true geometrical positions, i.e. the corners of a rectangle of 205 mm x 154 mm.

Front view and lug dimensions of tube M24-310

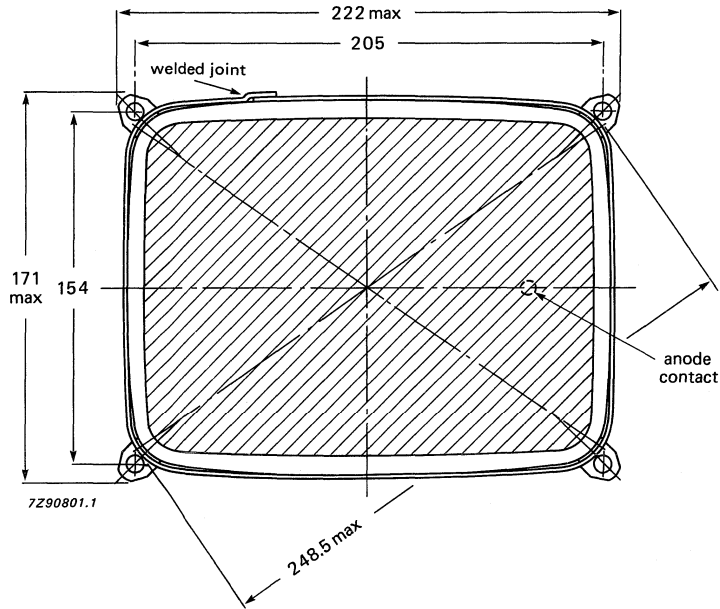

Fig. 19 Tube mounting dimensions; front view.

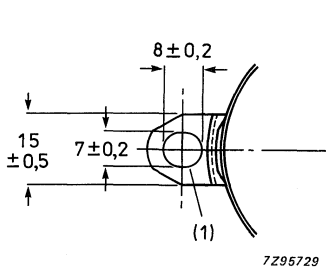

Fig. 20 Lug dimensions:

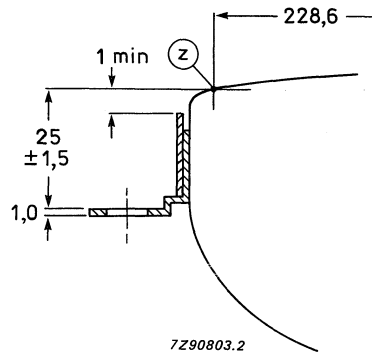

Fig. 21 Lug position.

(1) The position of the mounting screws in the cabinet must be within a circle of 4 mm diameter drawn around the true geometrical positions, i.e. the corners of a rectangle of 205 mm x 154 mm.

Front view and lug dimensions of tube M24-328 *

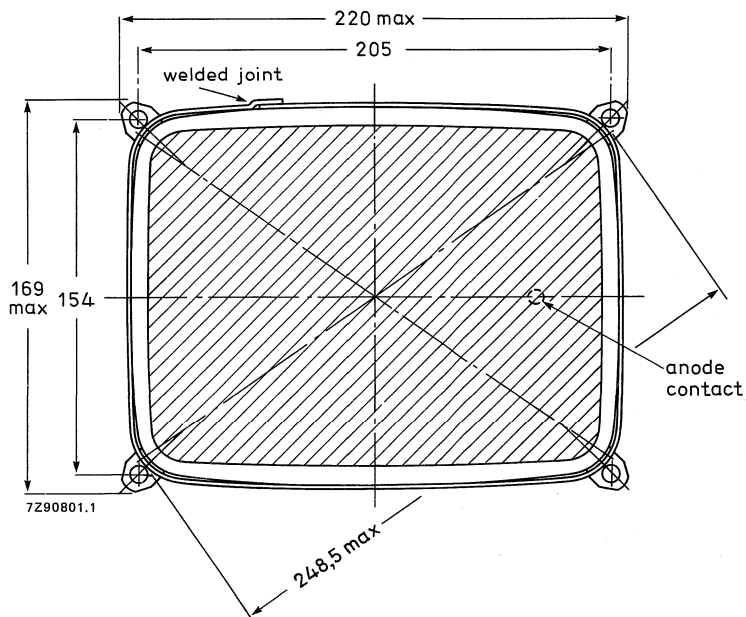

Fig. 22 Tube mounting dimensions; front view.

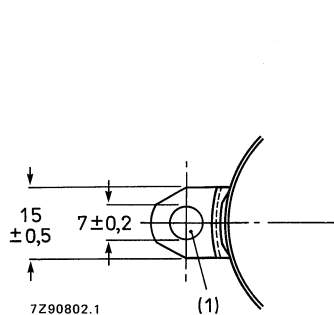

Fig. 23 Lug dimensions.

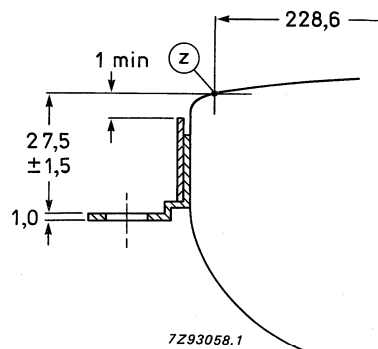

Fig. 24 Lug position.

(1) The position of the mounting screws in the cabinet must be within a circle of 4 mm diameter drawn around the true geometrical positions, i.e. the corners of a rectangle of 205 mm x 154 mm.

* This tube is still under development; data are provisional.

Maximum cone contour

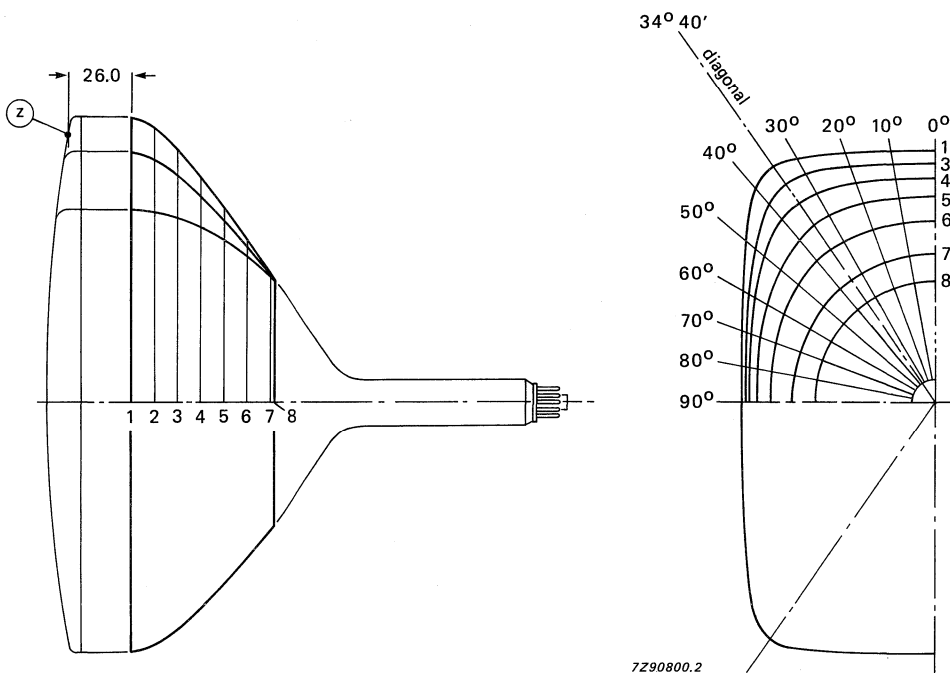

Fig. 25 Cone contour.

Table 1 Cone contour data

section	nom. distance from section 1	max. distance from centre										
		0°	10°	20°	30°	diag.	40°	50°	60°	70°	80°	90°
1	0	108,3	109,8	114,2	121,9	123,9	121,6	106,6	95,6	88,8	85,0	83,8
2	10	105,4	106,8	111,0	117,7	119,4	117,4	104,4	93,9	87,3	83,7	82,5
3	20	98,0	99,2	102,9	107,8	109,2	108,1	99,1	90,0	83,9	80,6	79,5
4	30	88,4	89,4	92,2	95,7	96,6	96,2	91,0	84,2	79,0	76,1	75,1
5	40	78,1	78,9	81,0	83,2	83,8	83,8	81,2	76,8	72,9	70,5	69,7
6	50	66,8	67,4	68,8	70,4	70,9	71,2	70,3	68,1	65,6	63,8	63,2
7	60	54,5	54,9	55,8	56,8	57,2	57,5	57,5	56,8	55,8	54,9	54,5
8	61,2	53,0	53,3	54,2	55,1	55,4	55,7	55,7	55,2	54,3	53,4	53,1

HIGH RESOLUTION MONOCHROME MONITOR TUBES

- For Data Graphic Displays
- 90° deflection angle
- 24 cm (9 in) face diagonal; rectangular glass
- 20 mm neck diameter
- Integral implosion protection

QUICK REFERENCE DATA

Deflection angle	90°
Face diagonal	24 cm (9 in)
Overall length	max. 227 mm
Neck diameter	20 mm
Heating	12 V/75 mA
Grid 2 voltage	700 V
Anode voltage	12 kV
Resolution	approx. 1300 lines

APPLICATION

These high resolution tubes are for alpha numeric and graphic display applications, such as computer terminals, small business computers, etc.

AVAILABLE VERSIONS

The following versions are available: M24-322 and M24-326. Differences between the tubes can be found under 'Dimensional data'.

The tubes can be supplied with different phosphors and anti-reflective treatments, see "High resolution monochrome monitor tubes, General".

ELECTRICAL DATA

Focusing method	electrostatic
Deflection method	magnetic
Deflection angles	
diagonal	approx. 90°
horizontal	approx. 82°
vertical	approx. 67°
Direct interelectrode capacitances	
cathode to all other electrodes	max. 5 pF
grid 1 to all other electrodes	max. 8 pF
Capacitance of external conductive coating to anode*	max. 850 pF min. 300 pF
Capacitance of external conductive coating to anode**	max. 750 pF min. 300 pF
Capacitance of anode to implosion protection hardware**	approx. 100 pF
Heater voltage	12 V
Heater current at 12 V	75 mA

OPTICAL DATA

Phosphor type	see "High resolution monochrome monitor tubes, General"
Light transmission at screen centre	
tube with normal tinted face glass	approx. 53%
tube with dark tinted face glass	approx. 42%

RASTER CENTRING

The field intensity perpendicular to the tube axis should be adjustable from 0 to 800 A/m. For optimum overall sharpness it is recommended to centre the raster electrically via the deflection coils.

* Implosion protection hardware connected to external conductive coating.

** Implosion protection hardware not connected to external conductive coating.

MECHANICAL DATA (see also the figures under Dimensions Data)

Overall length	max. 227 mm
Greatest dimensions of tube	
diagonal	248,5 mm
width	216 mm
height	167 mm
Minimum useful screen dimensions (projected)	
diagonal	222,5 mm
horizontal axis	193 mm
vertical axis	145 mm
area	268 cm ²
Implosion protection	T-band
Bulb	EIAJ-JB240AA03 or EIAJ-JB240AA04
Bulb contact designation	IEC 67-III-2, EIA-J1-21
Base designation	EIA E7-91
Basing	7GR
Mass	approx. 1,8 kg

RATINGS (Absolute Maximum System)

Unless otherwise specified voltage values are positive and measured with respect to grid 1.

Anode voltage	max. 15 kV min. 9,5 kV
Grid 4 (focusing electrode) voltage	-200 to + 1000 V
Grid 2 voltage	min. 400 V max. 1000 V
Anode current	
long-term average value	max. 130 μ A
peak value	max. 300 μ A
Cathode voltage, positive peak value	max. 400 V
Heater voltage	12 V +5/-10%*
Cathode-to-heater voltage	max. 100 V

* For maximum cathode life it is recommended that the heater supply be regulated at 12 V $\begin{matrix} +0\% \\ -5\% \end{matrix}$.

CIRCUIT DESIGN VALUES

Grid 4 current		
positive	max.	25 μ A
negative	max.	25 μ A
Grid 2 current		
positive	max.	5 μ A
negative	max.	5 μ A

MAXIMUM CIRCUIT VALUES

Resistance between cathode and heater	max.	1,0 $M\Omega$
Impedance between cathode and heater	max.	0,1 $M\Omega$
Grid 1 circuit resistance	max.	1,5 $M\Omega$
Grid 1 circuit impedance	max.	0,5 $M\Omega$

TYPICAL OPERATING CONDITIONS

Cathode drive; voltages specified with respect to grid 1

Anode voltage	12 kV
Grid 4 (focusing electrode) voltage	0 to 300 V*
Grid 2 voltage	700 V
Cathode cut-off voltage	57 to 97 V**

Grid drive; voltages specified with respect to cathode

Anode voltage	12 kV
Grid 4 (focusing electrode) voltage	0 to 300 V*
Grid 2 voltage	700 V
Grid 1 cut-off voltage	65 to 107 V**

RESOLUTION

The resolution is approx. 1300 lines. It is measured at the screen centre:

- with shrinking raster method,
- at light output 68,5 cd/m² (20 foot lambert) and raster dimensions 168 mm x 126 mm,
- at $V_{g2} = 700$ V and anode voltage = 12 kV,
- with phosphor type W (WW),
- with normal tinted face glass, without anti-glare treatment of screen surface.

X-RADIATION CHARACTERISTIC

X-radiation emitted will not exceed 0,5 mR/h throughout the useful life of the tube, when operated within the given ratings.

* Measured at screen centre on spot at anode current = 250 μ A (peak), anode voltage = 12 kV, grid 2 voltage = 700 V.

Dynamic focus (only for optimization): Typical correction for a video field of H x V = 168 mm x 126 mm:
line parabola 200 V;
field parabola 100 V.

** Visual extinction of focused raster.

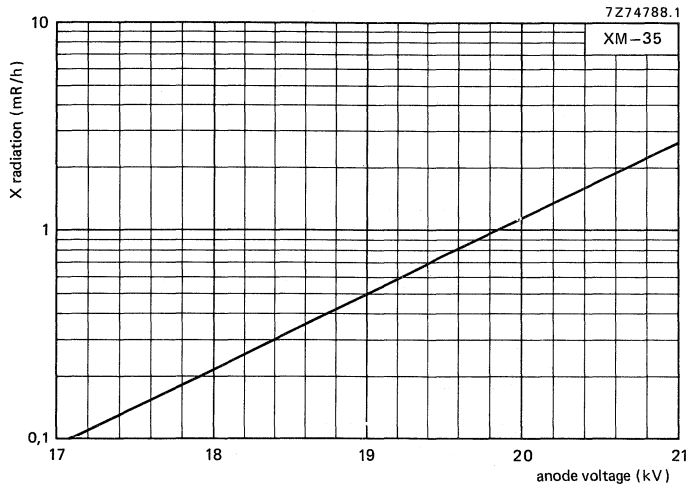

Fig. 1 X-radiation limit curve according to JEDEC94, at a constant anode current of 250 μ A, measured according to TEPAC103A.

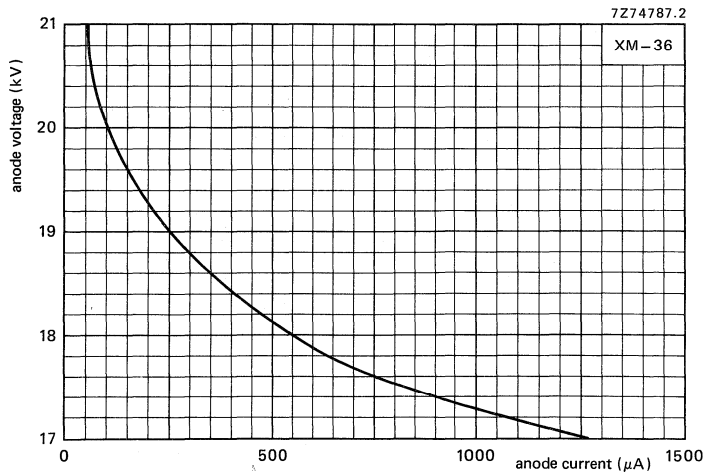

Fig. 2 0,5 mR/h isoexposure-rate limit curve, according to JEDEC94, measured according to TEPAC103A.

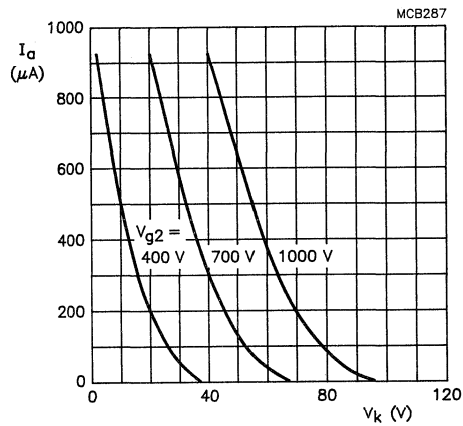

Fig. 3 Anode current as a function of cathode voltage.
Cathode drive; $V_{a,g3,g5} = 12$ kV.

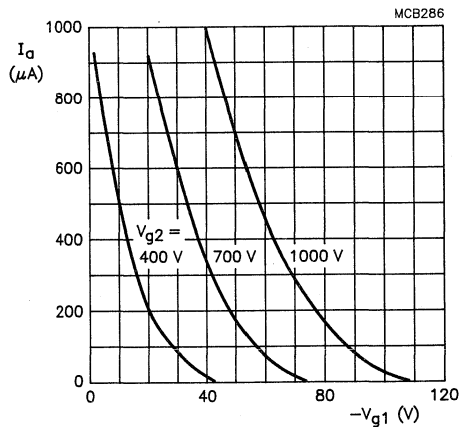

Fig. 4 Anode current as a function of grid 1 voltage.
Grid drive; $V_{a,g3,g5} = 12$ kV.

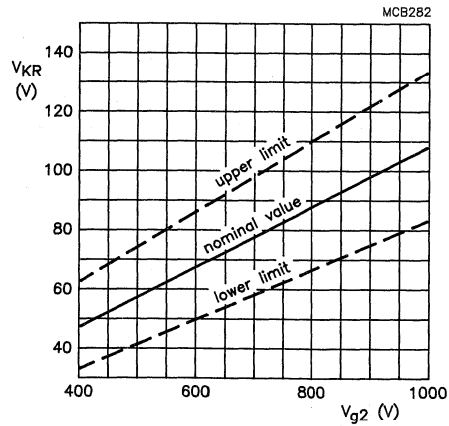

Fig. 5 Limits of cathode cut-off voltage as a function of grid 2 voltage. Cathode drive; $V_{a,g3,g5} = 12$ kV.

$$\frac{\Delta V_{KR}}{\Delta V_{a,g3,g5}} = 0.9 \times 10^{-3}$$

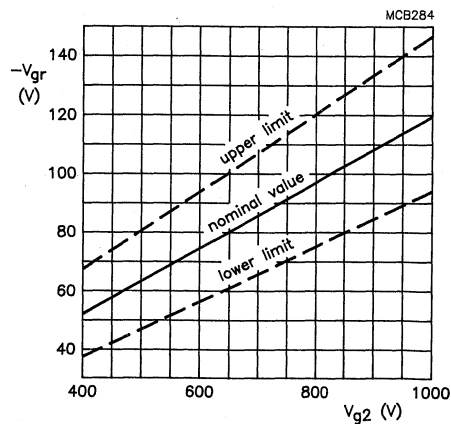

Fig. 6 Limits of grid 1 cut-off voltage as a function of grid 2 voltage. Grid drive; $V_{a,g3,g5} = 12$ kV.

$$\frac{\Delta V_{KR}}{\Delta V_{a,g3,g5}} = 0.9 \times 10^{-3}$$

DIMENSIONAL DATA

Dimensions in mm

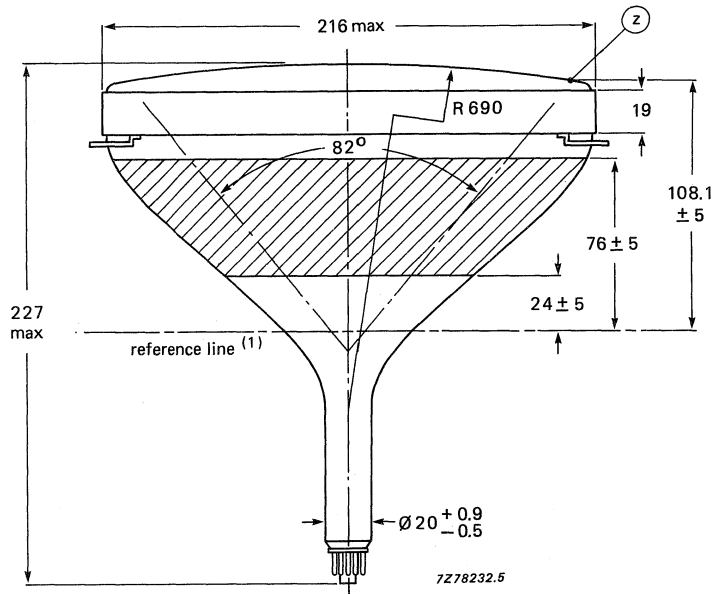

Fig. 7.

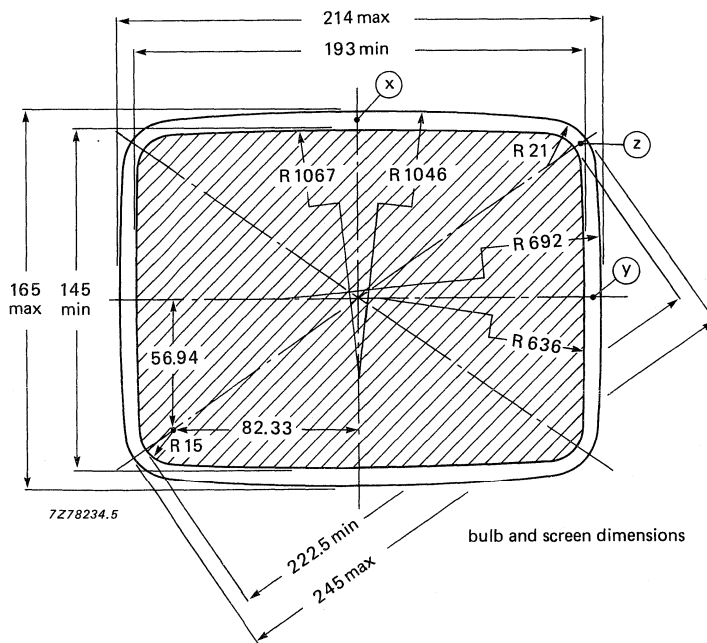

Fig. 8.

(1) The reference line is determined by the plane of the upper edge of reference line gauge D when the gauge is resting on the cone.

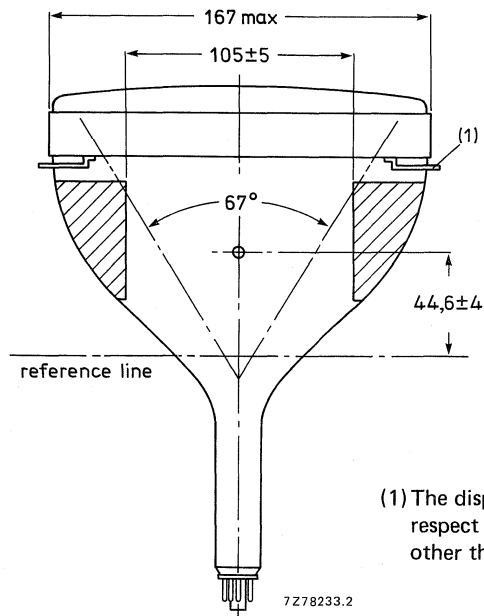

Fig. 9.

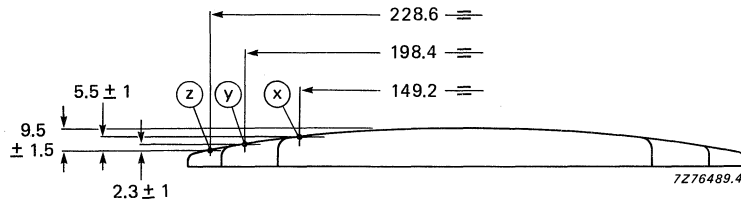

Fig. 10 Screen reference points.

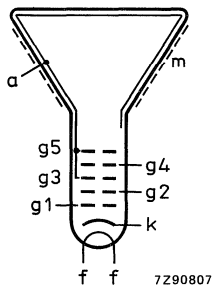

Fig. 11 Electrode configuration.

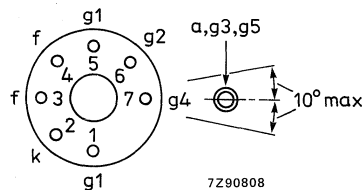

Fig. 12 Pin arrangement.

Front view and lug dimensions of tube M24-322

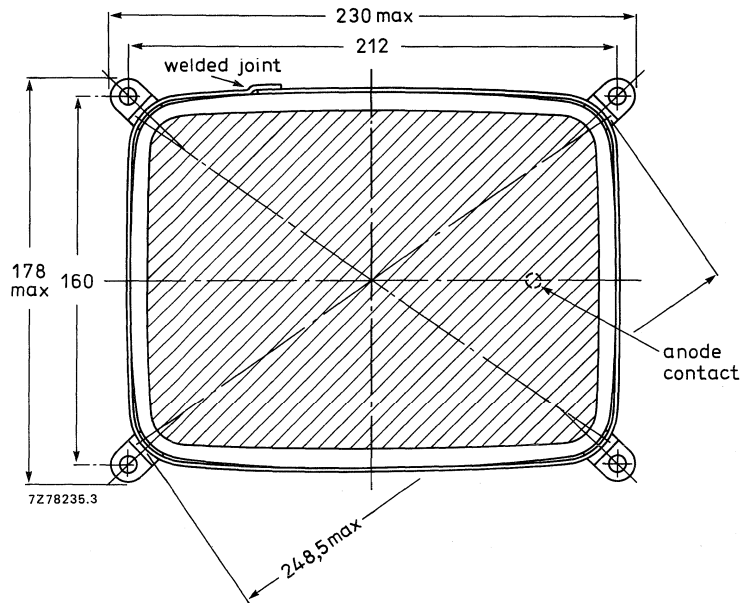

Fig. 13 Tube mounting dimensions; front view.

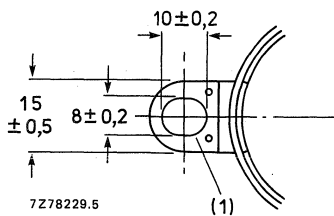

Fig. 14 Lug dimensions.

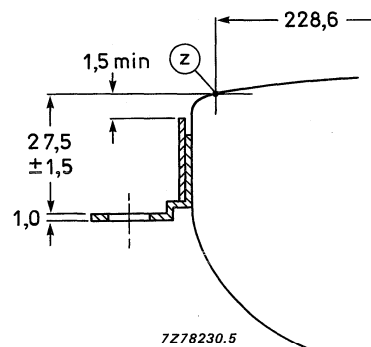

Fig. 15 Lug position.

(1) The position of the mounting screws in the cabinet must be within a circle of 5 mm diameter drawn around the true geometrical positions, i.e. the corners of a rectangle of 212 mm x 160 mm.

Front view and lug dimensions of tube M24-326

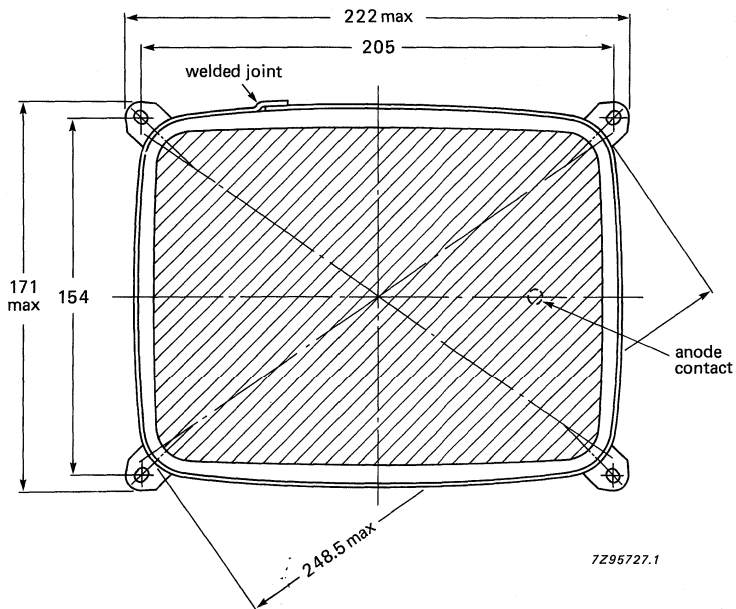

Fig. 16 Tube mounting dimensions; front view.

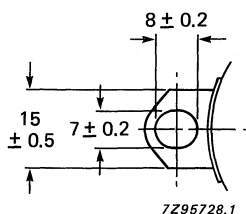

Fig. 17 Lug dimensions.

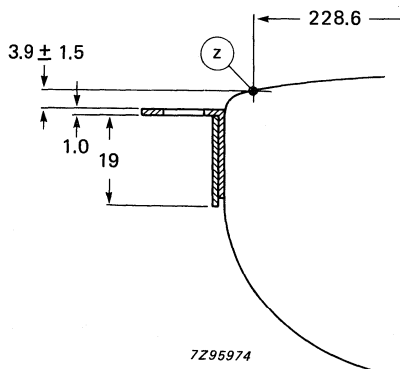

Fig. 18 Lug position.

(1) The position of the mounting screws in the cabinet must be within a circle of 3,4 mm diameter drawn around the true geometrical positions, i.e. the corners of a rectangle of 205 mm x 154 mm.

Maximum cone contour

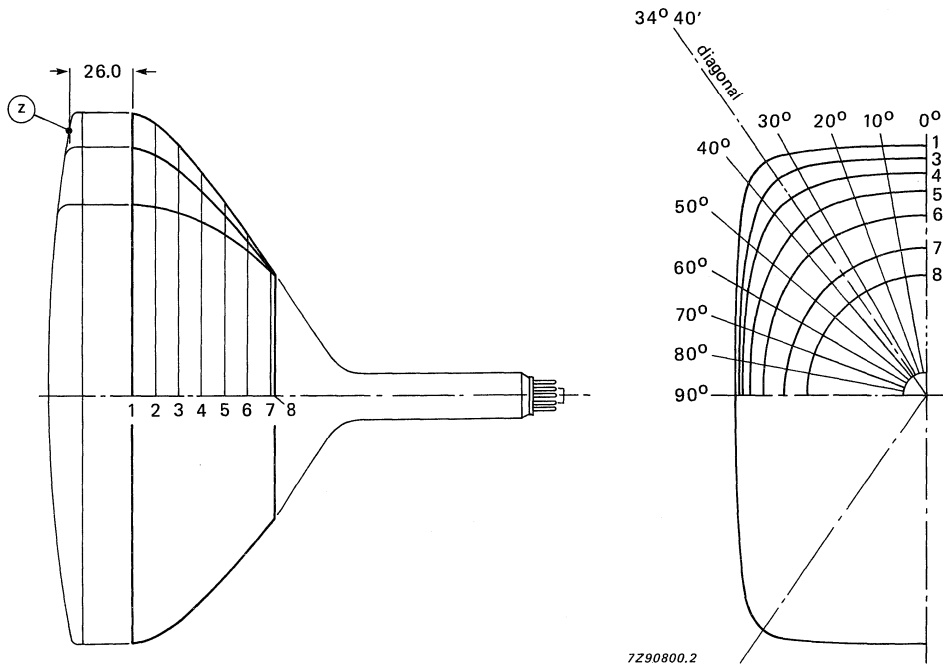

Fig. 19 Cone contour.

Table 1 Cone contour data

section	nom. distance from section 1	max. distance from centre										
		0°	10°	20°	30°	diag.	40°	50°	60°	70°	80°	90°
1	0	108,3	109,8	114,2	121,9	123,9	121,6	106,6	95,6	88,8	85,0	83,8
2	10	105,4	106,8	111,0	117,7	119,4	117,4	104,4	93,9	87,3	83,7	82,5
3	20	98,0	99,2	102,9	107,8	109,2	108,1	99,1	90,0	83,9	80,6	79,5
4	30	88,4	89,4	92,2	95,7	96,6	96,2	91,0	84,2	79,0	76,1	75,1
5	40	78,1	78,9	81,0	83,2	83,8	83,8	81,2	76,8	72,9	70,5	69,7
6	50	66,8	67,4	68,8	70,4	70,9	71,2	70,3	68,1	65,6	63,8	63,2
7	60	54,5	54,9	55,8	56,8	57,2	57,5	57,5	56,8	55,8	54,9	54,5
8	61,2	53,0	53,3	54,2	55,1	55,4	55,7	55,7	55,2	54,3	53,4	53,1

DEVELOPMENT DATA

This data sheet contains advance information and specifications are subject to change without notice.

M24-330

HIGH RESOLUTION MONOCHROME MONITOR TUBE

- For Data Graphic Displays
- 90° deflection angle
- 24 cm (9 in) face diagonal; rectangular glass
- 20 mm neck diameter
- Integral implosion protection

QUICK REFERENCE DATA

Deflection angle	90°
Face diagonal	24 cm (9 in)
Overall length	max. 227 mm
Neck diameter	20 mm
Heating	12 V/75 mA
Quick heating cathode	with a typical tube a legible picture will appear within 5 s
Grid 2 voltage	700 V
Anode voltage	12 kV
Resolution	approx. 1300 lines

APPLICATION

This high resolution tube is for alpha numeric and graphic display applications, such as computer terminals, small business computers, etc.

AVAILABLE VERSIONS

The tube can be supplied with different phosphors and anti-reflective treatments, see "High resolution monochrome monitor tubes, General".

ELECTRICAL DATA

Focusing method	electrostatic
Deflection method	magnetic
Deflection angles	
diagonal	approx. 90°
horizontal	approx. 82°
vertical	approx. 67°
Direct interelectrode capacitances	
cathode to all other electrodes	max. 5 pF
grid 1 to all other electrodes	max. 8 pF
Capacitance of external conductive coating to anode*	max. 850 pF min. 300 pF
Capacitance of external conductive coating to anode**	max. 750 pF min. 300 pF
Capacitance of anode to implosion protection hardware**	approx. 100 pF
Heater voltage	12 V
Heater current at 12 V	75 mA

OPTICAL DATA

Phosphor type	see "High resolution monochrome monitor tubes, General"
Light transmission at screen centre	
tube with normal tinted face glass	approx. 53%
tube with dark tinted face glass	approx. 42%

RASTER CENTRING

The field intensity perpendicular to the tube axis should be adjustable from 0 to 800 A/m. For optimum overall sharpness it is recommended to centre the raster electrically via the deflection coils.

* Implosion protection hardware connected to external conductive coating.

** Implosion protection hardware not connected to external conductive coating.

MECHANICAL DATA (see also the figures under Dimensional Data)

Overall length	max. 227 mm
Greatest dimensions of tube	
diagonal	248,5 mm
width	216 mm
height	167 mm
Minimum useful screen dimensions (projected)	
diagonal	222,5 mm
horizontal axis	193 mm
vertical axis	145 mm
area	268 cm ²
Implosion protection	T-band
Bulb	EIAJ-JB240AA03 or EIAJ-JB240AA04
Bulb contact designation	IEC 67-III-2, EIA-J1-21
Base designation	EIA E7-91
Basing	7GR
Mass	approx. 1,8 kg

DEVELOPMENT DATA

RATINGS (Absolute Maximum System)

Unless otherwise specified voltage values are positive and measured with respect to grid 1.

Anode voltage	max. 15 kV min. 9,5 kV
Grid 4 (focusing electrode) voltage	-200 to + 1000 V
Grid 2 voltage	min. 400 V max. 1000 V
Anode current	
long-term average value	max. 130 μ A
peak value	max. 300 μ A
Cathode voltage, positive peak value	max. 400 V
Heater voltage	12 V +5/-10%*
Cathode-to-heater voltage	max. 100 V

* For maximum cathode life it is recommended that the heater supply be regulated at 12 V $\begin{matrix} +0\% \\ -5\% \end{matrix}$

CIRCUIT DESIGN VALUES

Grid 4 current		
positive	max.	25 μA
negative	max.	25 μA
Grid 2 current		
positive	max.	5 μA
negative	max.	5 μA

MAXIMUM CIRCUIT VALUES

Resistance between cathode and heater	max.	1,0 $\text{M}\Omega$
Impedance between cathode and heater	max.	0,1 $\text{M}\Omega$
Grid 1 circuit resistance	max.	1,5 $\text{M}\Omega$
Grid 1 circuit impedance	max.	0,5 $\text{M}\Omega$

TYPICAL OPERATING CONDITIONS

Cathode drive; voltages specified with respect to grid 1

Anode voltage	12 kV
Grid 4 (focusing electrode) voltage	0 to 300 V*
Grid 2 voltage	700 V
Cathode cut-off voltage	57 to 97 V**

Grid drive; voltages specified with respect to cathode

Anode voltage	12 kV
Grid 4 (focusing electrode) voltage	0 to 300 V*
Grid 2 voltage	700 V
Grid 1 cut-off voltage	65 to 105 V**

RESOLUTION

The resolution is approx. 1300 lines. It is measured at the screen centre:

- with shrinking raster method
- at light output 68,5 cd/m^2 (20 foot lambert) and raster dimensions 168 mm x 126 mm
- at $V_{g2} = 700 \text{ V}$ and anode voltage = 12 kV
- with phosphor type W (WW)
- with normal tinted face glass, without anti-glare treatment of screen surface

X-RADIATION CHARACTERISTICS

X-radiation emitted will not exceed 0,5 mR/h throughout the useful life of the tube, when operated within the given ratings.

* Measured at screen centre on spot at anode current = 250 μA (peak), anode voltage = 12 kV, grid 2 voltage = 700 V.

Dynamic focus (only for optimization): Typical correction for a video field of $H \times V = 168 \text{ mm} \times 126 \text{ mm}$:
line parabola 200 V;
field parabola 100 V.

** Visual extinction of focused raster.

DEVELOPMENT DATA

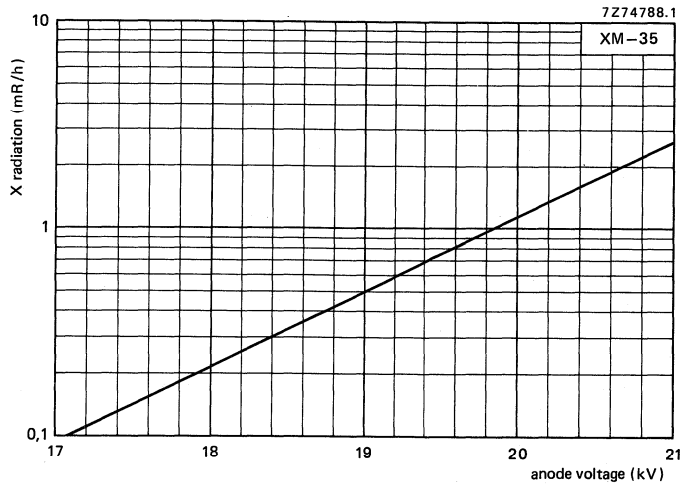

Fig. 1 X-radiation limit curve according to JEDEC94, at a constant anode current of 250 μ A, measured according to TEPAC103A.

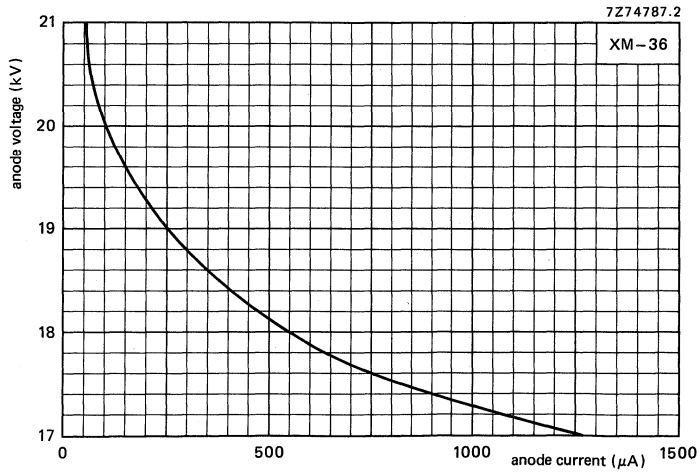

Fig. 2 0,5 mR/h isoexposure-rate limit curve, according to JEDEC94, measured according to TEPAC103A.

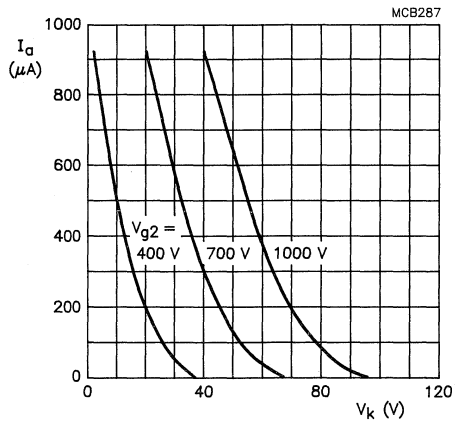

Fig. 3 Anode current as a function of cathode voltage.
Cathode drive; $V_{a,g3,g5} = 12$ kV.

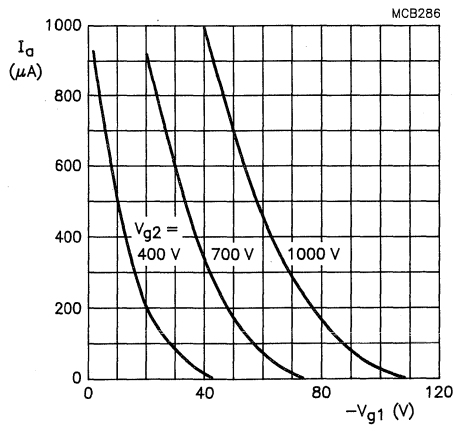

Fig. 4 Anode current as a function of grid 1 voltage.
Grid drive; $V_{a,g3,g5} = 12$ kV.

DEVELOPMENT DATA

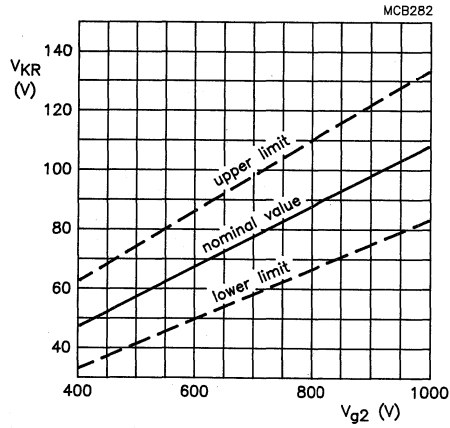

Fig. 5 Limits of cathode cut-off voltage as a function of grid 2 voltage. Cathode drive; $V_{a,g3,g5} = 12$ kV.

$$\frac{\Delta V_{KR}}{\Delta V_{a,g3,g5}} = 0.9 \times 10^{-3}$$

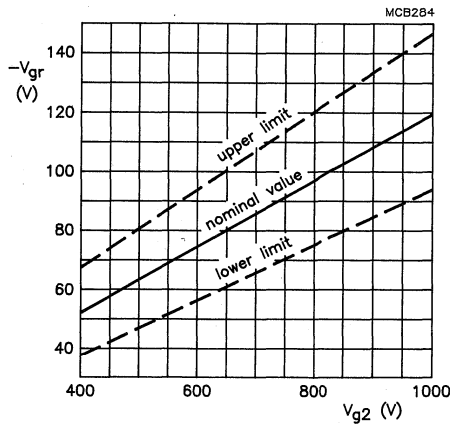

Fig. 6 Limits of grid 1 cut-off voltage as a function of grid 2 voltage. Grid drive; $V_{a,g3,g5} = 12$ kV.

$$\frac{\Delta V_{GR}}{\Delta V_{a,g3,g5}} = 0.9 \times 10^{-3}$$

DIMENSIONAL DATA

Dimensions in mm

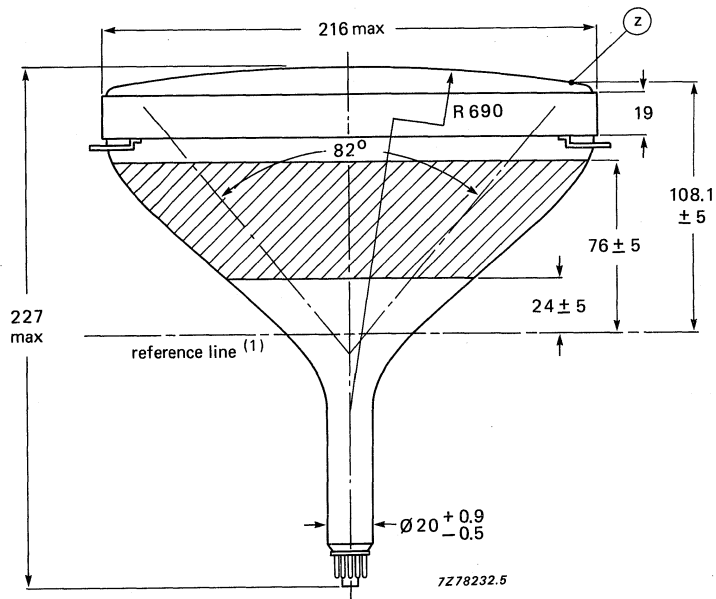

Fig. 7.

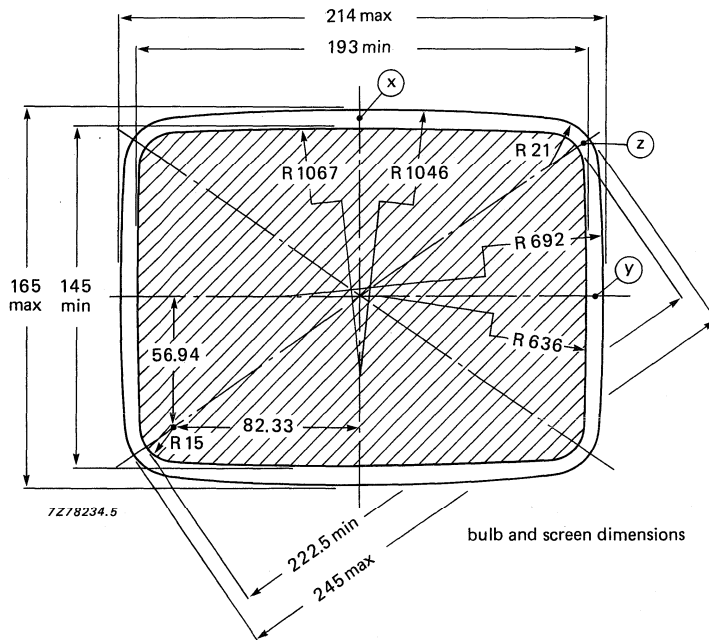

Fig. 8.

(1) The reference line is determined by the plane of the upper edge of reference line gauge D when the gauge is resting on the cone.

DEVELOPMENT DATA

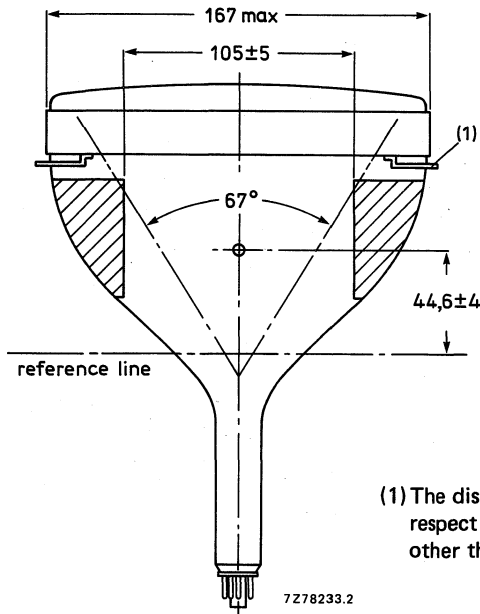

Fig. 9.

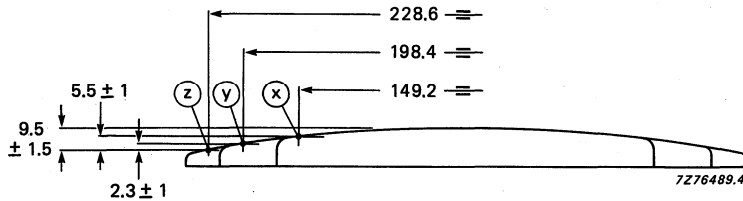

Fig. 10 Screen reference points.

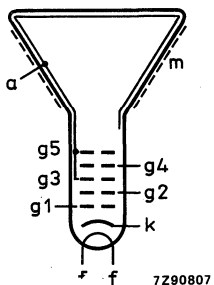

Fig. 11 Electrode configuration.

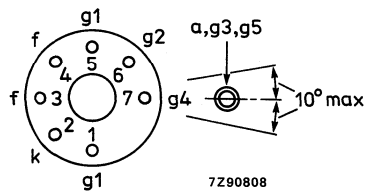

Fig. 12 Pin arrangement; bottom view.

Front view and lug dimensions

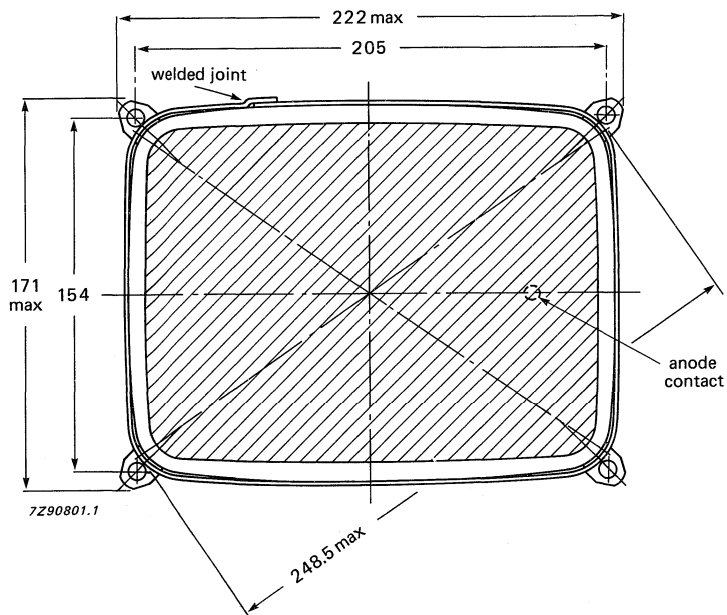

Fig. 13 Tube mounting dimensions; front view.

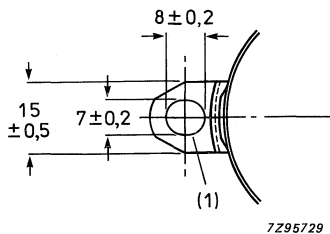

Fig. 14 Lug dimensions.

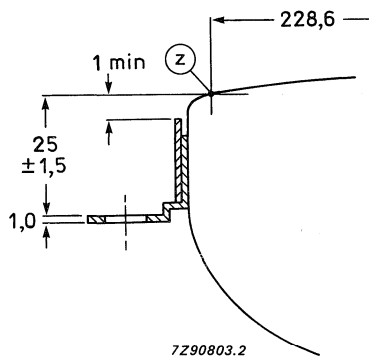

Fig. 15 Lug position.

(1) The position of the mounting screws in the cabinet must be within a circle of 4 mm diameter drawn around the true geometrical positions, i.e. the corners of a rectangle of 205 mm x 154 mm.

Maximum cone contour

DEVELOPMENT DATA

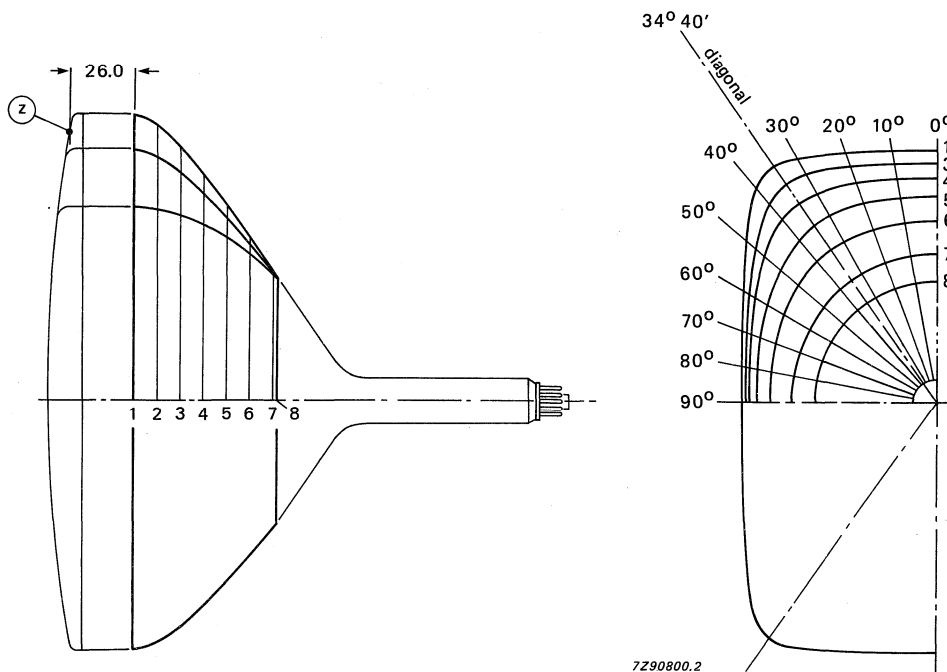

Fig. 16 Cone contour.

Table 1 Cone contour data

section	nom. distance from section 1	max. distance from centre										
		0°	10°	20°	30°	diag.	40°	50°	60°	70°	80°	90°
1	0	108,3	109,8	114,2	121,9	123,9	121,6	106,6	95,6	88,8	85,0	83,8
2	10	105,4	106,8	111,0	117,7	119,4	117,4	104,4	93,9	87,3	83,7	82,5
3	20	98,0	99,2	102,9	107,8	109,2	108,1	99,1	90,0	83,9	80,6	79,5
4	30	88,4	89,4	92,2	95,7	96,6	96,2	91,0	84,2	79,0	76,1	75,1
5	40	78,1	78,9	81,0	83,2	83,8	83,8	81,2	76,8	72,9	70,5	69,7
6	50	66,8	67,4	68,8	70,4	70,9	71,2	70,3	68,1	65,6	63,8	63,2
7	60	54,5	54,9	55,8	56,8	57,2	57,5	57,5	56,8	55,8	54,9	54,5
8	61,2	53,0	53,3	54,2	55,1	55,4	55,7	55,7	55,2	54,3	53,4	53,1

MONOCHROME MONITOR TUBE

- 90° deflection angle
- 24 cm (9 in) face diagonal; rectangular glass
- 20 mm neck diameter
- Integral implosion protection

QUICK REFERENCE DATA

Deflection angle	90°
Face diagonal	24 cm (9 in)
Overall length	max. 227 mm
Neck diameter	20 mm
Heating	11 V/140 mA
Quick heating cathode	with a typical tube a legible picture will appear within 5 s
Grid 2 voltage	130 V
Anode voltage	12 kV
Resolution	approx. 800 lines

APPLICATION

This monitor tube is for alpha numeric and graphic display applications, such as computer terminals, small business computers, etc.

ELECTRICAL DATA

Focusing method	electrostatic
Deflection method	magnetic
Deflection angles	
diagonal	approx. 90°
horizontal	approx. 82°
vertical	approx. 67°
Direct interelectrode capacitances	
cathode to all other electrodes	max. 4 pF
grid 1 to all other electrodes	max. 8 pF
Capacitance of external conductive coating to anode*	max. 850 pF min. 300 pF
Capacitance of external conductive coating to anode**	max. 750 pF min. 300 pF
Capacitance of anode to implosion protection hardware**	approx. 100 pF
Heater voltage	11 V
Heater current at 11 V	140 mA

OPTICAL DATA

Phosphor type	W (P4)
Light transmission at screen centre	approx. 53%

RASTER CENTRING

The field intensity perpendicular to the tube axis should be adjustable from 0 to 800 A/m. For optimum overall sharpness it is recommended to centre the raster electrically via the deflection coils.

* Implosion protection hardware connected to external conductive coating.

** Implosion protection hardware not connected to external conductive coating.

MECHANICAL DATA (see also the figures under Dimensions Data)

Overall length	max. 227 mm
Greatest dimensions of tube	
diagonal	249,5 mm
width	216 mm
height	167 mm
Minimum useful screen dimensions (projected)	
diagonal	222,5 mm
horizontal axis	193 mm
vertical axis	145 mm
area	268 cm ²
Implosion protection	T-band
Bulb	EIAJ-JB240AA03
Bulb contact designation	IEC 67-III-2, EIA-J1-21
Base designation	EIA E7-91
Basing	7GR
Mass	approx. 1,8 kg

RATINGS (Absolute Maximum System)

Unless otherwise specified voltage values are positive and measured with respect to grid 1.

Anode voltage	max. 15 kV min. 9,5 kV
Grid 4 (focusing electrode) voltage	-200 to +500 V
Grid 2 voltage	max. 200 V
Cathode voltage, positive peak value	max. 200 V
Heater voltage	11 V +5/-10%*
Cathode-to-heater voltage	max. 100 V

CIRCUIT DESIGN VALUES

Grid 4 current	
positive	max. 25 μ A
negative	max. 25 μ A
Grid 2 current	
positive	max. 5 μ A
negative	max. 5 μ A

MAXIMUM CIRCUIT VALUES

Resistance between cathode and heater	max. 1,0 M Ω
Impedance between cathode and heater	max. 0,1 M Ω
Grid 1 circuit resistance	max. 1,5 M Ω
Grid 1 circuit impedance	max. 0,5 M Ω

* For maximum cathode life it is recommended that the heater supply be regulated at 11 V $\begin{matrix} +0\% \\ -5\% \end{matrix}$.

TYPICAL OPERATING CONDITIONS

Cathode drive; voltages specified with respect to grid 1

Anode voltage	12 kV
Grid 4 (focusing electrode) voltage	130 V*
Grid 2 voltage	130 V
Cathode cut-off voltage	45 to 65 V**

RESOLUTION

The resolution is approx. 800 lines. It is measured at the screen centre:

- with shrinking raster method,
- at light output $68,5 \text{ cd/m}^2$ (20 foot lambert) and raster dimensions 168 mm x 126 mm,
- at $V_{g2} = 200 \text{ V}$ and anode voltage = 12 kV,
- with phosphor type W (WW)
- with normal tinted face glass, without anti-glare treatment of screen surface.

X-RADIATION CHARACTERISTIC

X-radiation emitted will not exceed 0,5 mR/h throughout the useful life of the tube, when operated within the given ratings.

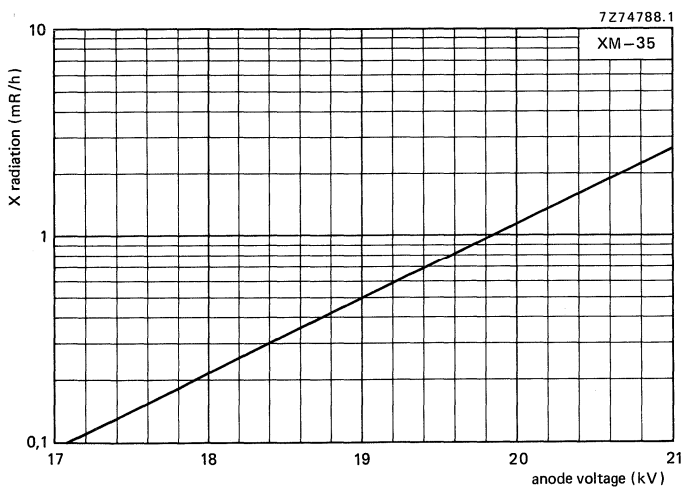

Fig.1 X-radiation limit curve according to JEDEC94, at a constant anode current of $250 \mu\text{A}$, measured according TEPAC103A.

- * Measured at screen centre on spot at anode current = $250 \mu\text{A}$ (peak), anode voltage = 12 kV, grid 2 voltage = 130 V.
Because of the flat focus characteristic it is sufficient to choose a focusing voltage between 0 V and + 130 V. The optimum focus voltage of individual tubes may be between - 150 and + 50 V.
- ** Visual extinction of focused raster.

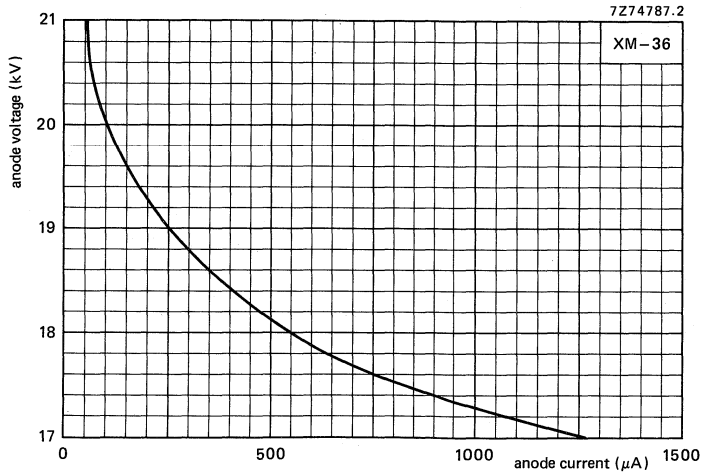

Fig. 2 0,5 mR/h isoexposure-rate limit curve, according to JEDEC94, measured according to TEPAC103A.

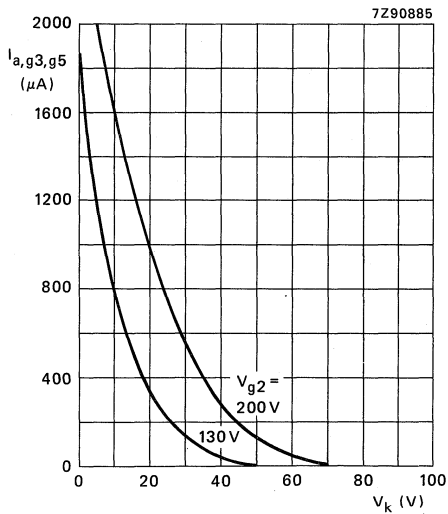

Fig. 3 Anode current as a function of cathode voltage.
Cathode drive; $V_{a,g3,g5} = 12$ kV.

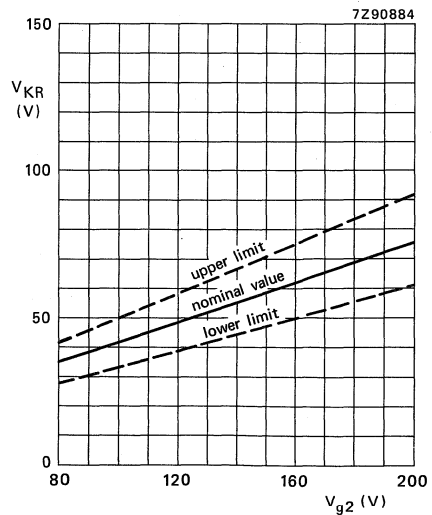
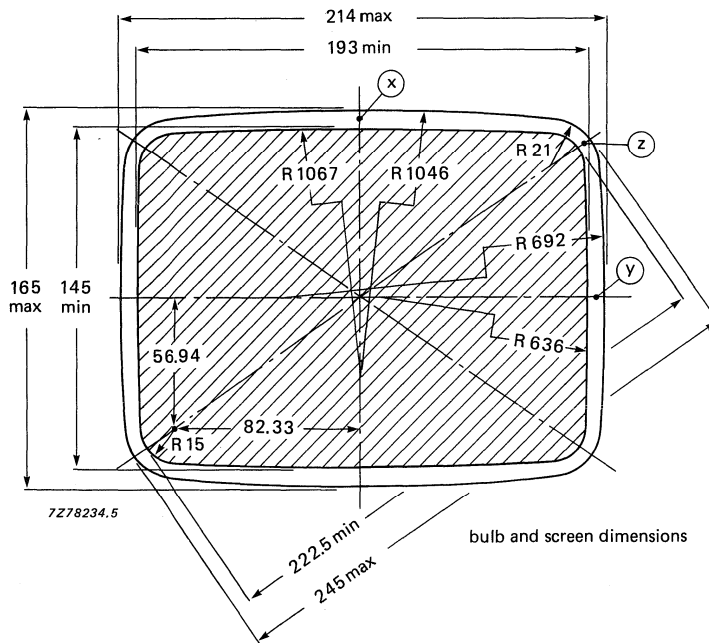
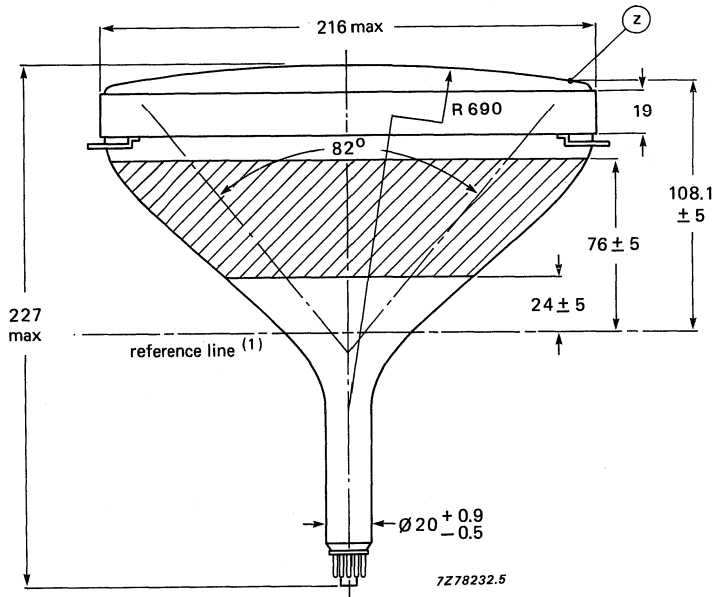

Fig. 4 Limits of cathode cut-off voltage as a function of grid 2 voltage.
Cathode drive; $V_{a,g3,g5} = 12$ kV.

$$\frac{\Delta V_{KR}}{\Delta V_{a,g3,g5}} = 0,3 \times 10^{-3}$$

DIMENSIONAL DATA

Dimensions in mm



(1) The reference line is determined by the plane of the upper edge of reference line gauge D when the gauge is resting on the cone.

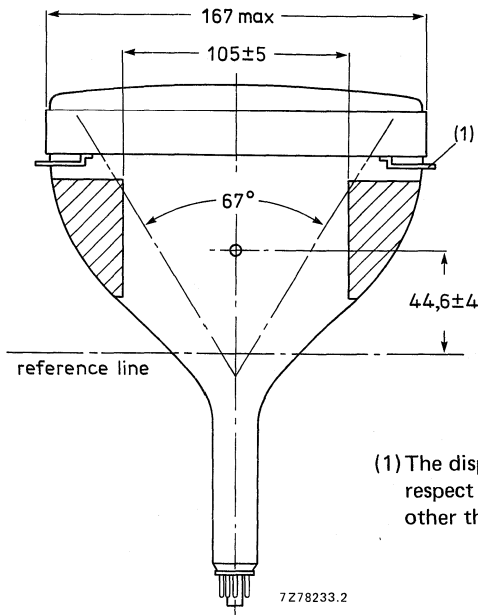

Fig. 7.

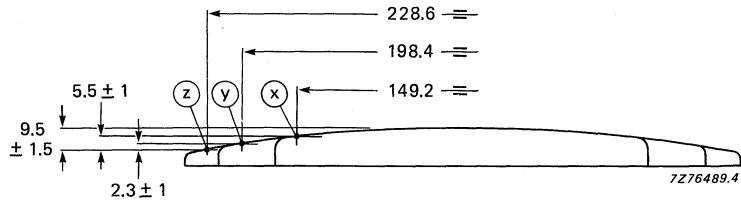

Fig. 8 Screen reference points.

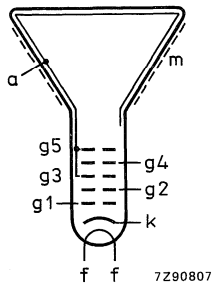

Fig. 9 Electrode configuration.

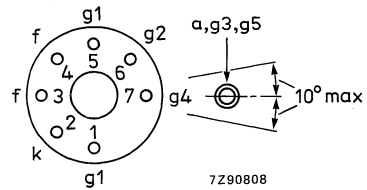

Fig. 10 Pin arrangement.

Front view and lug dimensions of tube

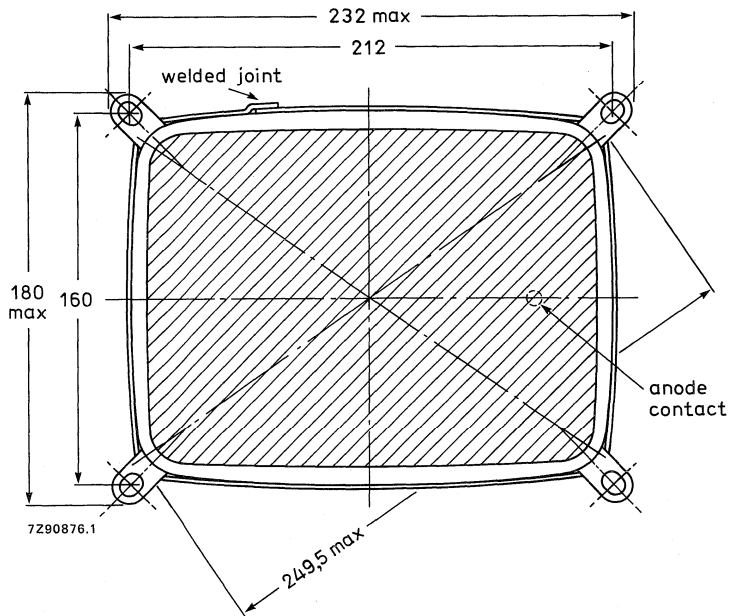

Fig. 11 Tube mounting dimensions; front view.

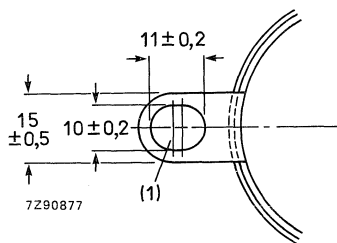

Fig. 12 Lug dimensions.

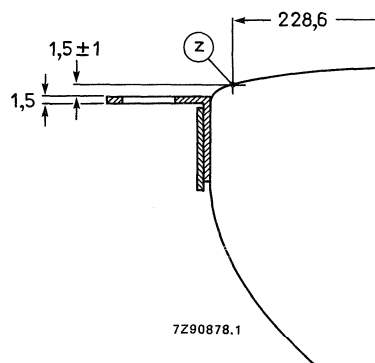

Fig. 13 Lug position.

(1) The position of the mounting screws in the cabinet must be within a circle of 7 mm diameter drawn around the true geometrical positions, i.e. the corners of a rectangle of 212 mm x 160 mm.

Maximum cone contour

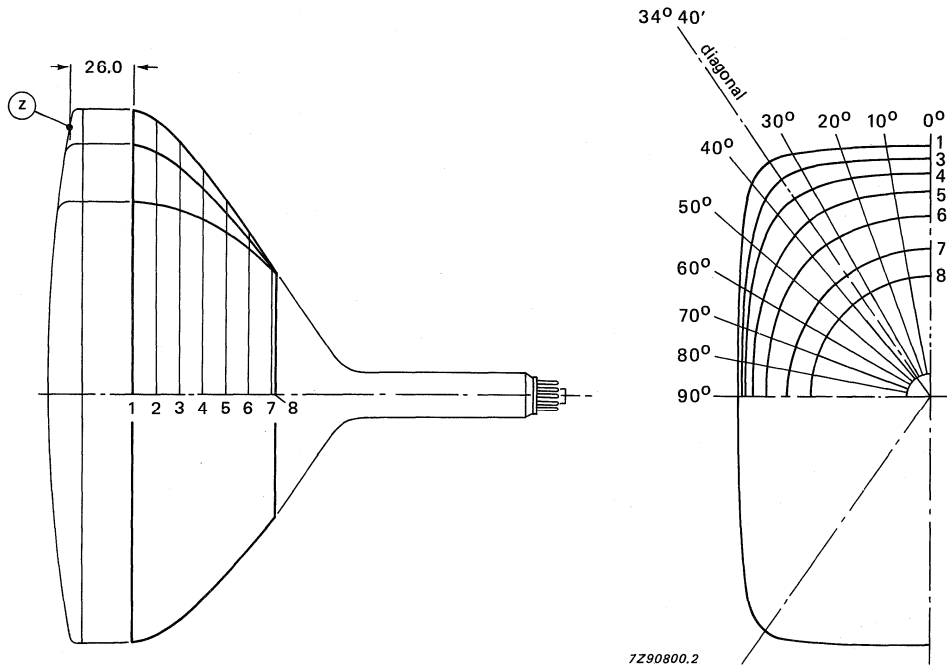

Fig. 14 Cone contour.

Table 1 Cone contour data

section	nom. distance from section 1	max. distance from centre										
		0°	10°	20°	30°	diag.	40°	50°	60°	70°	80°	90°
1	0	108,3	109,8	114,2	121,9	123,9	121,6	106,6	95,6	88,8	85,0	83,8
2	10	105,4	106,8	111,0	117,7	119,4	117,4	104,4	93,9	87,3	83,7	82,5
3	20	98,0	99,2	102,9	107,8	109,2	108,1	99,1	90,0	83,9	80,6	79,5
4	30	88,4	89,4	92,2	95,7	96,6	96,2	91,0	84,2	79,0	76,1	75,1
5	40	78,1	78,9	81,0	83,2	83,8	83,8	81,2	76,8	72,9	70,5	69,7
6	50	66,8	67,4	68,8	70,4	70,9	71,2	70,3	68,1	65,6	63,8	63,2
7	60	54,5	54,9	55,8	56,8	57,2	57,5	57,5	56,8	55,8	54,9	54,5
8	61,2	53,0	53,3	54,2	55,1	55,4	55,7	55,7	55,2	54,3	53,4	53,1

FLAT SQUARE HIGH RESOLUTION MONOCHROME MONITOR TUBES

- For Data Graphic Displays
- 90° deflection angle
- 31 cm (12 in) face diagonal; rectangular glass
- 1200 mm radius of screen curvature
- 20 mm neck diameter
- Integral implosion protection

QUICK REFERENCE DATA

Deflection angle	90°
Face diagonal	31 cm (12 in)
Overall length	max. 275 mm
Neck diameter	20 mm
Heating	12 V/130 mA
Quick heating cathode	with a typical tube a legible picture will appear within 5 s
Grid 2 voltage	700 V
Anode voltage	12 kV
Resolution	approx. 1300 lines

APPLICATION

These high resolution tubes are for alpha numeric and graphic display applications, such as computer terminals, small business computers, etc.

AVAILABLE VERSIONS

The following versions are available: M29EAA and M29EAB.

The tubes can be supplied with different phosphors and anti-reflective treatments, see "High resolution monochrome monitor tubes, General".

Differences between the tubes can be found under 'Dimensional data'.

ELECTRICAL DATA

Focusing method	electrostatic
Deflection method	magnetic
Deflection angles	
diagonal	approx. 90°
horizontal	approx. 79°
vertical	approx. 61°
Interelectrode capacitances	
cathode to all other electrodes	max. 5 pF
grid 1 to all other electrodes	max. 7 pF
Capacitance of external conductive coating to anode*	max. 1250 pF min. 800 pF
Heater voltage	12 V
Heater current at 12 V	130 mA

OPTICAL DATA

Phosphor type	see "High resolution monochrome monitor tubes, General"
Light transmission at screen centre	
tube with normal tinted face glass	approx. 43%
tube with dark tinted face glass	approx. 32%

RASTER CENTRING

The field intensity perpendicular to the tube axis should be adjustable from 0 to 800 A/m. For optimum overall sharpness it is recommended to centre the raster electrically via the deflection coils.

* Implosion protection hardware connected to external conductive coating.

MECHANICAL DATA (see also the figures under Dimensional Data)

Overall length	max. 275 mm
Greatest dimensions of tube	
diagonal	323.5 mm
width	273 mm
height	212.5 mm
Minimum useful screen dimensions (projected)	
diagonal	294 mm
horizontal axis	246 mm
vertical axis	181 mm
area	440 cm ²
Implosion protection	T-band
Bulb	EIAJ-JB320AA03 or EIAJ-JB320AA04
Bulb contact designation	IEC 67-III-2, EIAJ1-21
Base designation	EIA E7-91
Basing	7GR
Mass	approx. 3,5 kg

RATINGS (Absolute Maximum System)

Unless otherwise specified voltage values are positive and measured with respect to grid 1.

Anode voltage	max. 15 kV min. 10 kV
Grid 4 (focusing electrode) voltage	-200 to + 1000 V
Grid 2 voltage	min. 400 V max. 1000V
Anode current	
long-term average value	max. 130 μ A
peak value	max. 300 μ A
Cathode voltage, positive peak value	max. 400 V
Heater voltage	12 V +5/-10%*
Cathode-to-heater voltage	max. 100 V

* For maximum cathode life it is recommended that the heater supply be regulated at 12 V $\begin{matrix} +0\% \\ -5\% \end{matrix}$

CIRCUIT DESIGN VALUES

Grid 4 current	
positive	max. 25 μ A
negative	max. 25 μ A
Grid 2 current	
positive	max. 5 μ A
negative	max. 5 μ A

MAXIMUM CIRCUIT VALUES

Resistance between cathode and heater	max. 1,0 M Ω
Impedance between cathode and heater	max. 0,1 M Ω
Grid 1 circuit resistance	max. 1,5 M Ω
Grid 1 circuit impedance	max. 0,5 M Ω

TYPICAL OPERATING CONDITIONS

Cathode drive; voltages specified with respect to grid 1

Anode voltage	12 kV
Grid 4 (focusing electrode) voltage	0 to 300 V*
Grid 2 voltage	700 V
Cathode cut-off voltage	57 to 97 V**

Grid drive; voltages specified with respect to cathode

Anode voltage	12 kV
Grid 4 (focusing electrode) voltage	0 to 300 V*
Grid 2 voltage	700 V
Grid 1 cut-off voltage	65 to 107 V**

RESOLUTION

The resolution is approx. 1300 lines. It is measured at the screen centre:

- with shrinking raster method,
- at light output 68,5 cd/m² (20 foot lambert) and raster dimensions 216 mm x 162 mm,
- at $V_{g2} = 700$ V and anode voltage = 12 kV,
- with phosphor type W (WW),
- with normal tinted face glass, without anti-glare treatment of screen surface.

X-RADIATION CHARACTERISTIC

X-radiation emitted will not exceed 0,5 mR/h throughout the useful life of the tube, when operated within the given ratings.

* Measured at screen centre on spot at anode current = 250 μ A (peak), anode voltage = 12 kV, grid 2 voltage = 700 V.

Dynamic focus (only for optimization): Typical correction for a video field of H x V = 216 mm x 162 mm:
line parabola 250 V,
field parabola 0 V.

** Visual extinction of focused raster.

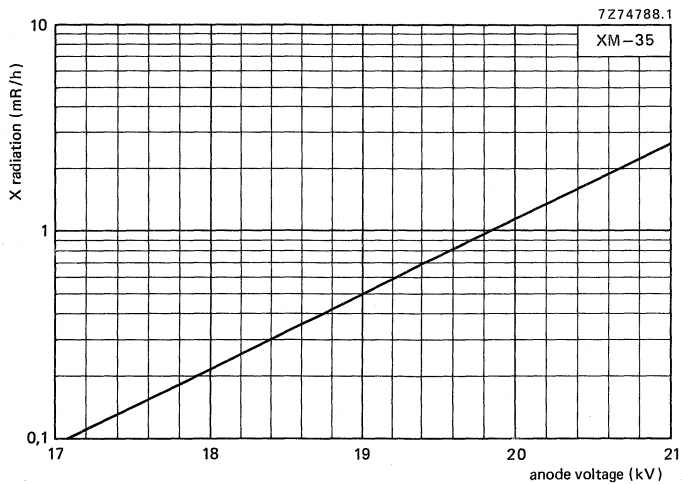

Fig. 1 X-radiation limit curve according to JEDEC 94, at a constant anode current of 250 μA , measured according to TEPAC103A.

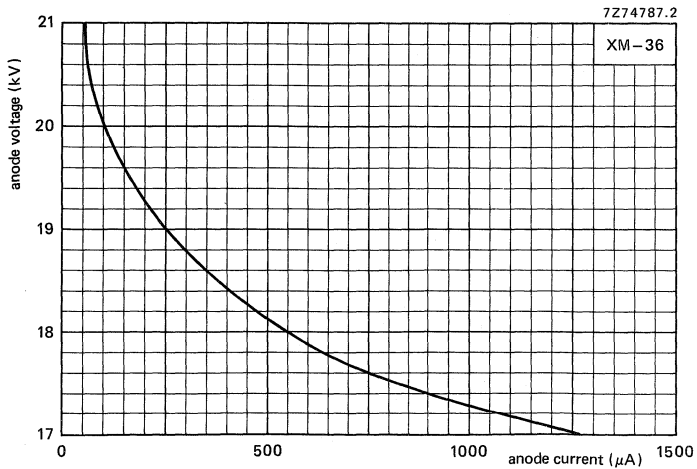

Fig. 2 0,5 mR/h isoexposure-rate limit curve, according to JEDEC 94, measured according to TEPAC103A.

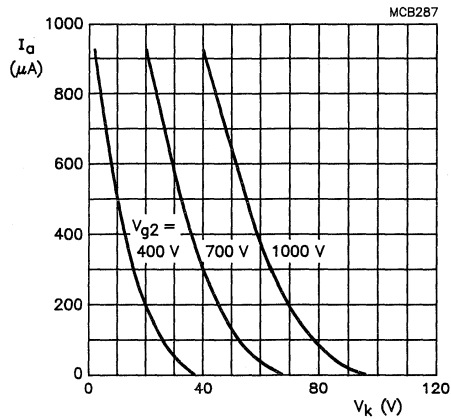

Fig. 3 Anode current as a function of cathode voltage.
Cathode drive; $V_{a,g3,g5} = 12$ kV.

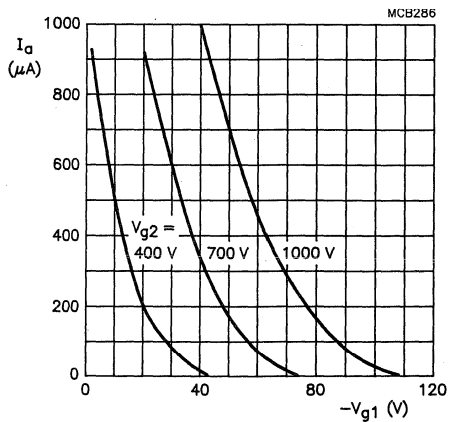

Fig. 4 Anode current as a function of grid 1 voltage.
Grid drive; $V_{a,g3,g5} = 12$ kV.

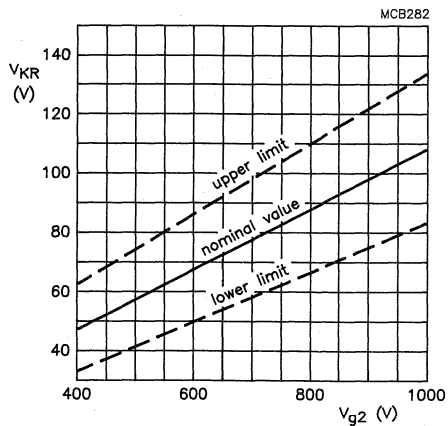

Fig. 5 Limits of cathode raster cut-off voltage as a function of grid 2 voltage. Cathode drive; $V_{a,g3,g5} = 12$ kV.

$$\frac{\Delta V_{KR}}{\Delta V_{a,g3,g5}} = 0.9 \times 10^{-3}.$$

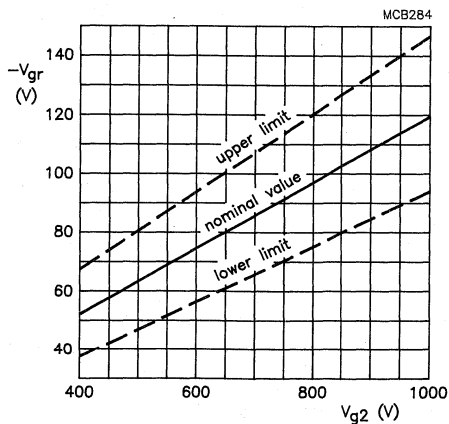

Fig. 6 Limits of grid 1 raster cut-off voltage as a function of grid 2 voltage. Grid drive; $V_{a,g3,g5} = 12$ kV.

$$\frac{\Delta V_{GR}}{\Delta V_{a,g3,g5}} = 0.9 \times 10^{-3}.$$

DIMENSIONAL DATA

Dimensions in mm

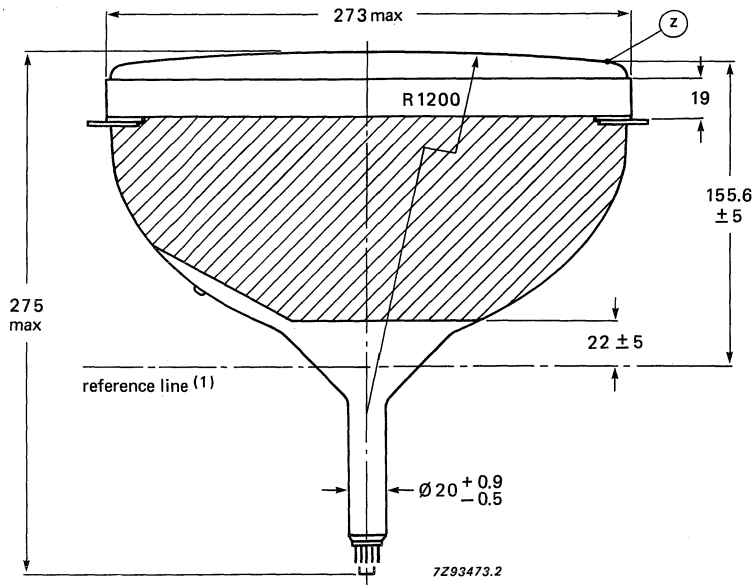

Fig. 7

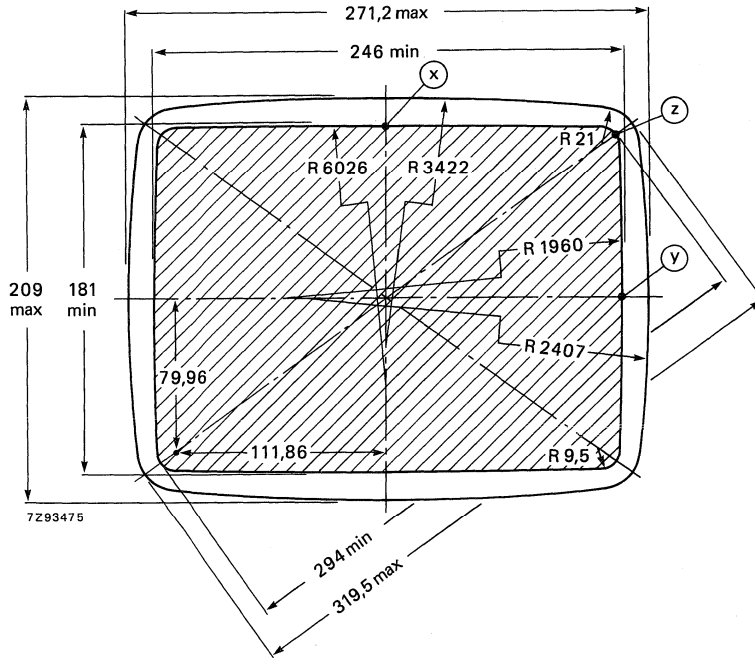
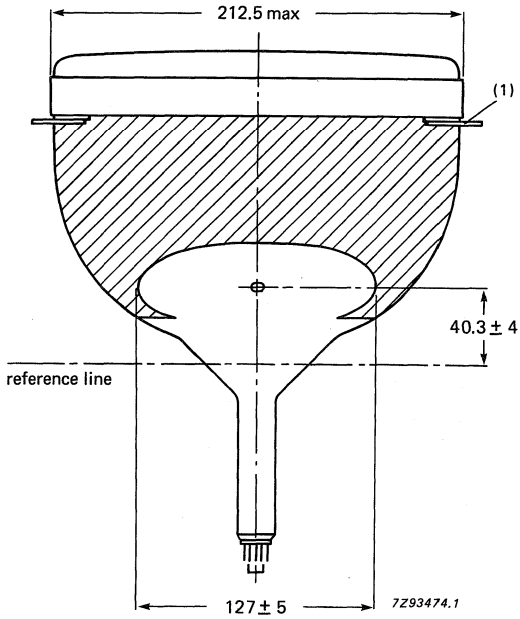

Fig. 8

(1) The reference line is determined by the plane of the upper edge of reference line gauge D when the gauge is resting on the cone.



(1) The displacement of any lug with respect to the plane through the other three lugs is max. 2 mm.

Fig. 9

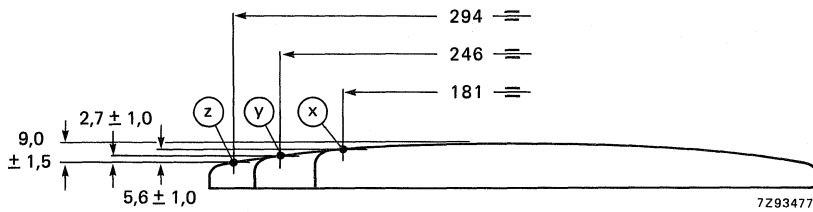

Fig. 10 Screen reference points.

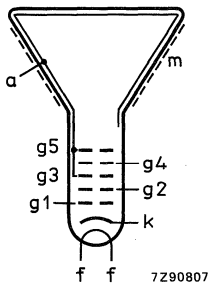

Fig. 11 Electrode configuration.

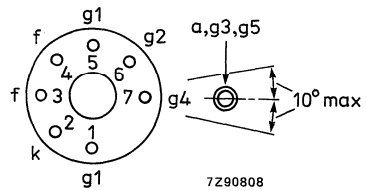

Fig. 12 Pin arrangement.

Front view of tube M29EAA

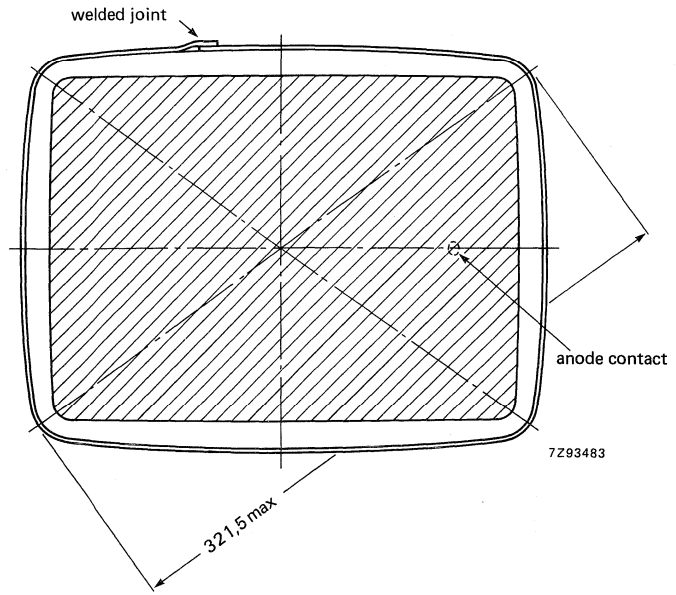

Fig. 13 Tube front view with rimband.

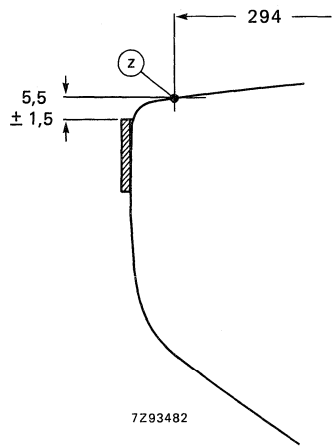

Fig. 14 Rimband position.

Front view and lug dimensions of tube M29EAB *

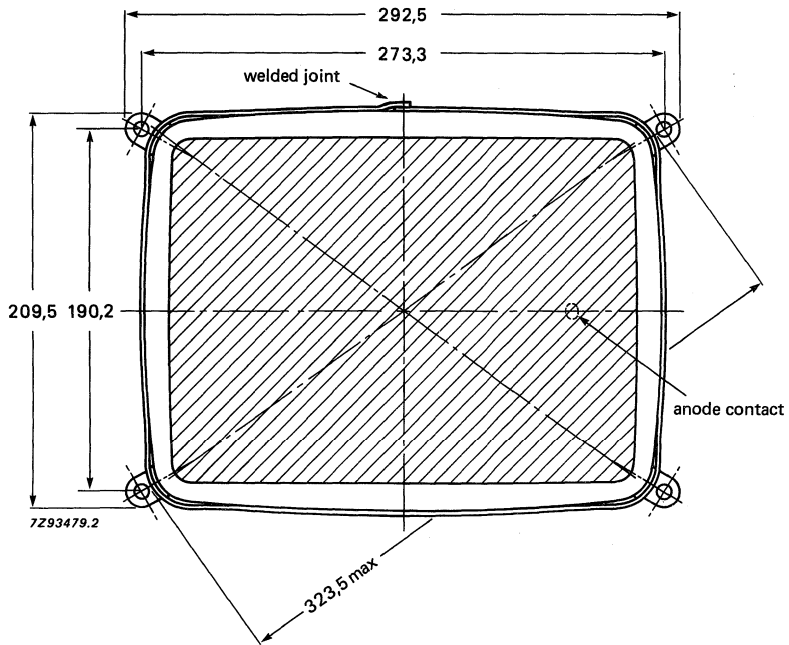

Fig. 15 Tube mounting dimensions; front view.

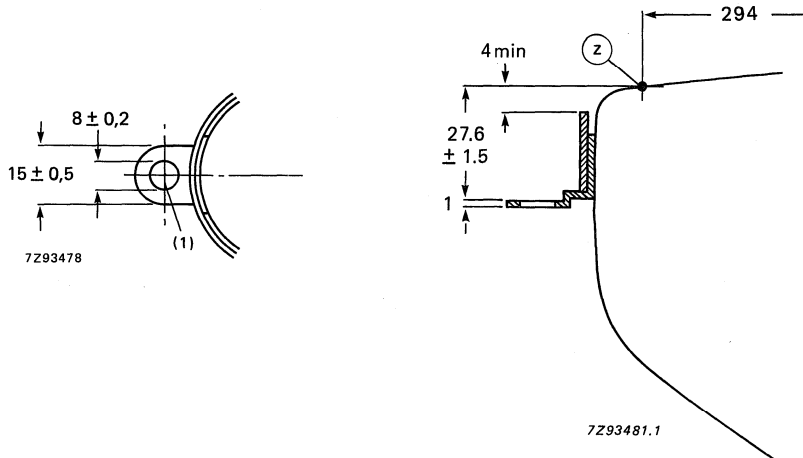

Fig. 16 Lug dimensions.

Fig. 17 Lug position.

(1) The mounting screws in the cabinet must be situated inside a circle of 5 mm diameter drawn around the true geometrical positions i.e. at the corners of a rectangle of 273.3 mm x 190.2 mm

* This tube is still under development; data are provisional.

Maximum cone contour

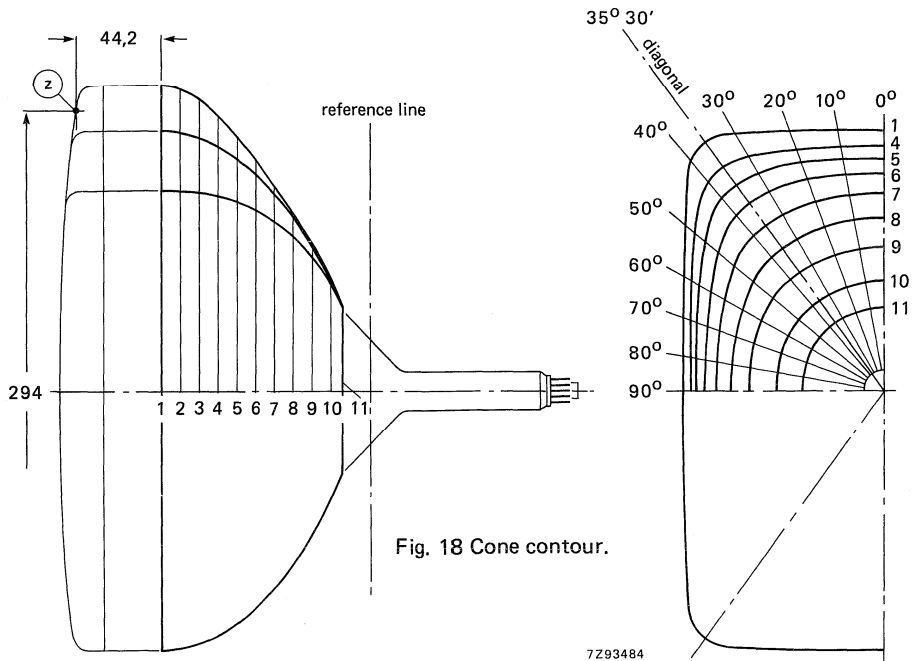

Table 1 Cone contour data

sec- tion	nom. distance from section 1	max. distance from centre										
		0°	10°	20°	30°	diag.	40°	50°	60°	70°	80°	90°
1	0	136,4	138,3	144,5	155,6	160,5	157,5	135,6	120,8	111,8	106,8	105,3
2	10	135,5	137,4	143,5	154,1	158,6	155,8	135,2	120,6	111,6	106,7	105,1
3	20	132,7	134,6	140,4	149,7	153,2	151,1	133,6	119,4	110,6	105,8	104,3
4	30	128,2	129,9	135,0	142,0	144,0	142,3	129,3	116,6	108,4	103,9	102,4
5	40	121,8	123,3	127,3	132,0	132,8	131,5	122,5	112,2	104,8	100,6	99,3
6	50	113,6	114,8	117,7	120,4	120,6	119,5	113,5	105,7	99,5	95,8	94,6
7	60	103,3	104,2	105,9	107,1	106,9	106,1	102,2	96,9	92,2	89,1	88,1
8	70	90,7	91,2	92,1	92,5	92,2	91,7	89,4	86,2	83,1	80,8	80,0
9	80	75,3	75,7	76,3	76,6	76,6	76,5	75,6	74,0	72,3	71,0	70,4
10	90	57,7	57,7	57,7	57,7	57,6	57,6	57,4	57,2	57,0	56,8	56,6
11	96,5	44,7	44,7	44,7	44,7	44,7	44,7	44,7	44,7	44,7	44,7	44,7

FLAT SQUARE HIGH RESOLUTION MONOCHROME MONITOR TUBES

- For Data Graphic Displays
- 90° deflection angle
- 31 cm (12 in) face diagonal; rectangular glass
- 1200 mm radius of screen curvature
- 20 mm neck diameter
- Integral implosion protection

QUICK REFERENCE DATA

Deflection angle	90°
Face diagonal	31 cm (12 in)
Overall length	max. 275 mm
Neck diameter	20 mm
Heating	12 V/75 mA
Grid 2 voltage	700 V
Anode voltage	12 kV
Resolution	approx. 1300 lines

APPLICATION

These high resolution tubes are for alpha numeric and graphic display applications, such as computer terminals, small business computers, etc.

AVAILABLE VERSIONS

The following versions are available: M29ECA and M29ECB.

The tubes can be supplied with different phosphors and anti-reflective treatments, see "High resolution monochrome monitor tubes, General".

Differences between the tubes can be found under 'Dimensional data'.

ELECTRICAL DATA

Focusing method	electrostatic
Deflection method	magnetic
Deflection angles	
diagonal	approx. 90°
horizontal	approx. 79°
vertical	approx. 61°
Interelectrode capacitances	
cathode to all other electrodes	max. 5 pF
grid 1 to all other electrodes	max. 8 pF
Capacitance of external conductive coating to anode*	max. 1250 pF min. 800 pF
Heater voltage	12 V
Heater current at 12 V	75 mA

OPTICAL DATA

Phosphor type	see "High resolution monochrome monitor tubes, General"
Light transmission at screen centre	
tube with normal tinted face glass	approx. 43%
tube with dark tinted face glass	approx. 32%

RASTER CENTRING

The field intensity perpendicular to the tube axis should be adjustable from 0 to 800 A/m. For optimum overall sharpness it is recommended to centre the raster electrically via the deflection coils.

* Implosion protection hardware connected to external conductive coating.

FLAT SQUARE

High resolution monochrome monitor tubes

**M29ECA
M29ECB****MECHANICAL DATA** (see also the figures under Dimensional Data)

Overall length	max. 275 mm
Greatest dimensions of tube	
diagonal	323,5 mm
width	273 mm
height	212,5 mm
Minimum useful screen dimensions (projected)	
diagonal	294 mm
horizontal axis	246 mm
vertical axis	181 mm
area	440 cm ²
Implosion protection	T-band
Bulb	EIAJ-JB320AA03 or EIAJ-JB320AA04
Bulb contact designation	IEC 67-III-2, EIAJ1-21
Base designation	EIA E7-91
Basing	7GR
Mass	approx. 3,5 kg

RATINGS (Absolute Maximum System)

Unless otherwise specified voltage values are positive and measured with respect to grid 1.

Anode voltage	max. 15 kV min. 10 kV
Grid 4 (focusing electrode) voltage	-200 to + 1000 V
Grid 2 voltage	max. 1000 V min. 400 V
Anode current	
long-term average value	max. 130 μ A
peak value	max. 300 μ A
Cathode voltage, positive peak value	max. 400 V
Heater voltage	12 V +5/-10%*
Cathode-to-heater voltage	max. 100 V

* For maximum cathode life it is recommended that the heater supply be regulated at 12 V $\begin{matrix} +0\% \\ -5\% \end{matrix}$.

CIRCUIT DESIGN VALUES

Grid 4 current	
positive	max. 25 μ A
negative	max. 25 μ A
Grid 2 current	
positive	max. 5 μ A
negative	max. 5 μ A

MAXIMUM CIRCUIT VALUES

Resistance between cathode and heater	max. 1,0 Ω
Impedance between cathode and heater	max. 0,1 Ω
Grid 1 circuit resistance	max. 1,5 Ω
Grid 1 circuit impedance	max. 0,5 Ω

TYPICAL OPERATING CONDITIONS

Cathode drive; voltages specified with respect to grid 1

Anode voltage	12 kV
Grid 4 (focusing electrode) voltage	0 to 300 V*
Grid 2 voltage	700 V
Cathode cut-off voltage	57 to 97 V**

Grid drive; voltages specified with respect to cathode

Anode voltage	12 kV
Grid 4 (focusing electrode) voltage	0 to 300 V*
Grid 2 voltage	700 V
Grid 1 cut-off voltage	65 to 107 V**

RESOLUTION

The resolution is approx. 1300 lines. It is measured at the screen centre:

- with shrinking raster method,
- at light output 68,5 cd/m² (20 foot lambert) and raster dimensions 216 mm x 162 mm,
- at $V_{g2} = 700$ V and anode voltage = 12 kV,
- with phosphor type WW,
- with normal tinted face glass, without anti-glare treatment of screen surface.

X-RADIATION CHARACTERISTIC

X-radiation emitted will not exceed 0,5 mR/h throughout the useful life of the tube, when operated within the given ratings.

* Measured at screen centre on spot at anode current = 250 μ A (peak), anode voltage = 12 kV, grid 2 voltage = 700 V.

Dynamic focus (only for optimization): Typical correction for a video field of H x V = 216 mm x 162 mm:
line parabola 250 V,
field parabola 0 V.

** Visual extinction of focused raster.

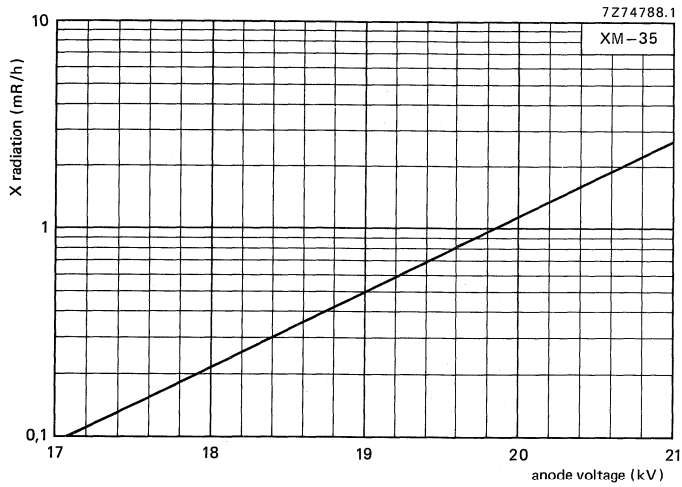

Fig. 1 X-radiation limit curve according to JEDEC 94, at a constant anode current of $250 \mu\text{A}$, measured according to TEPAC103A.

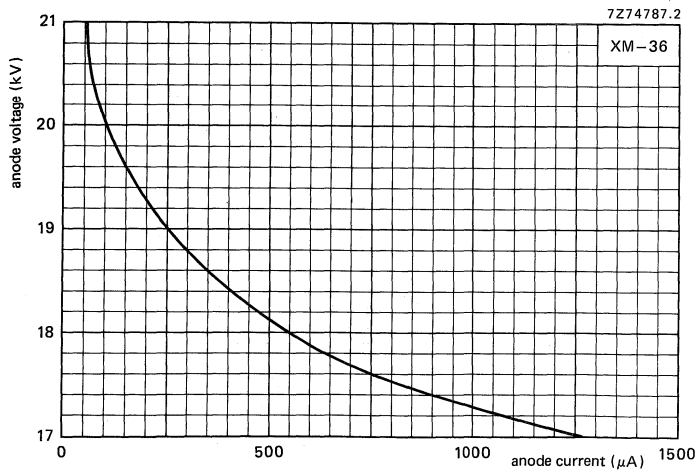

Fig. 2 0,5 mR/h isoexposure-rate limit curve, according to JEDEC 94, measured according to TEPAC103A.

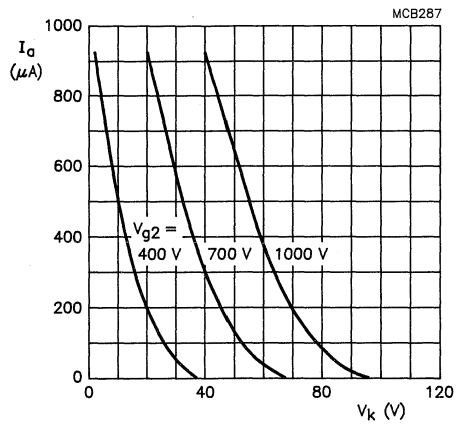

Fig. 3 Anode current as a function of cathode voltage.
Cathode drive; $V_{a,g3,g5} = 12 \text{ kV}$.

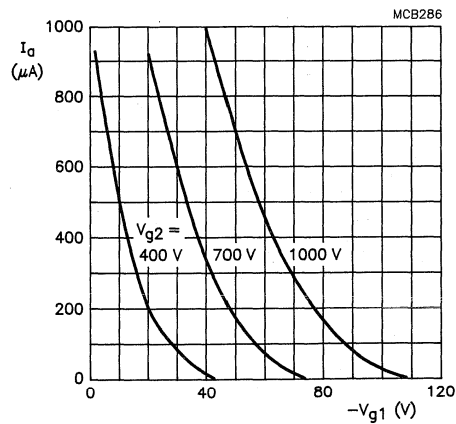

Fig. 4 Anode current as a function of grid 1 voltage.
Grid drive; $V_{a,g3,g5} = 12 \text{ kV}$.

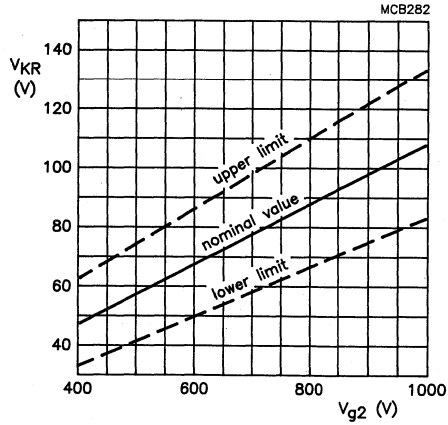

Fig. 5 Limits of cathode raster cut-off voltage as a function of grid 2 voltage.
Cathode drive; $V_{a,g3,g5} = 12$ kV.

$$\frac{\Delta V_{KR}}{\Delta V_{a,g3,g5}} = 0.9 \times 10^{-3}.$$

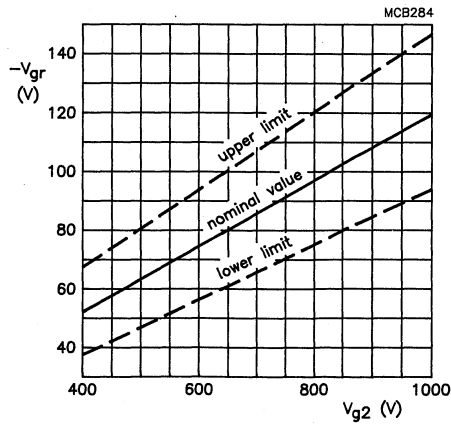
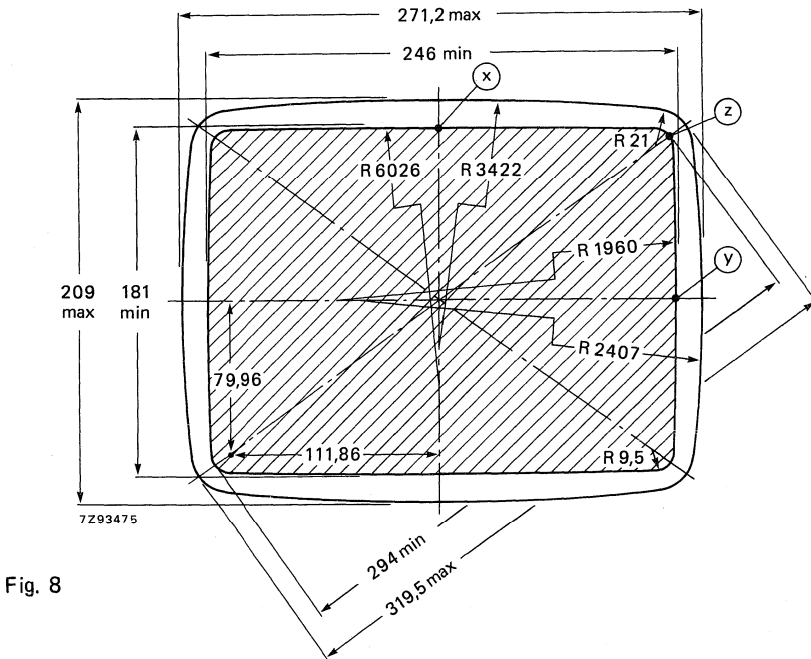
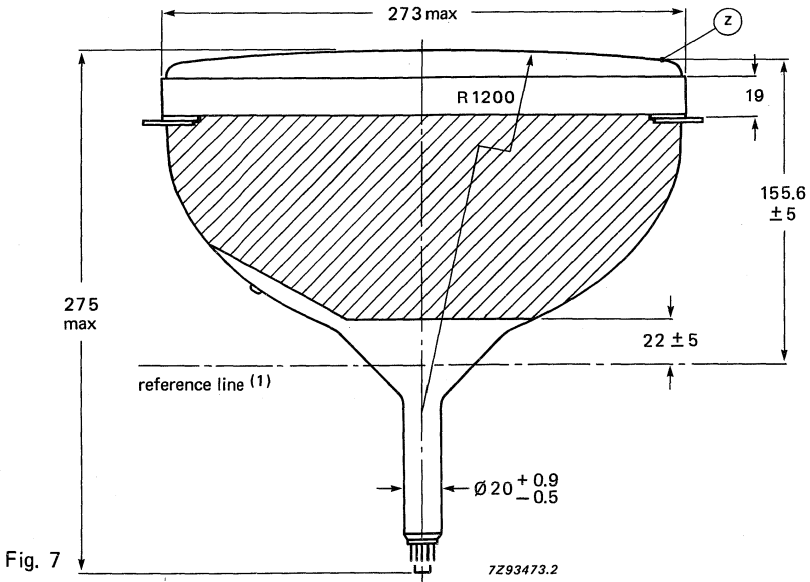

Fig. 6 Limits of grid 1 raster cut-off voltage as a function of grid 2 voltage.
Grid drive; $V_{a,g3,g5} = 12$ kV.

$$\frac{\Delta V_{GR}}{\Delta V_{a,g3,g5}} = 0.9 \times 10^{-3}.$$

DIMENSIONAL DATA

Dimensions in mm



(1) The reference line is determined by the plane of the upper edge of reference line gauge D when the gauge is resting on the cone.

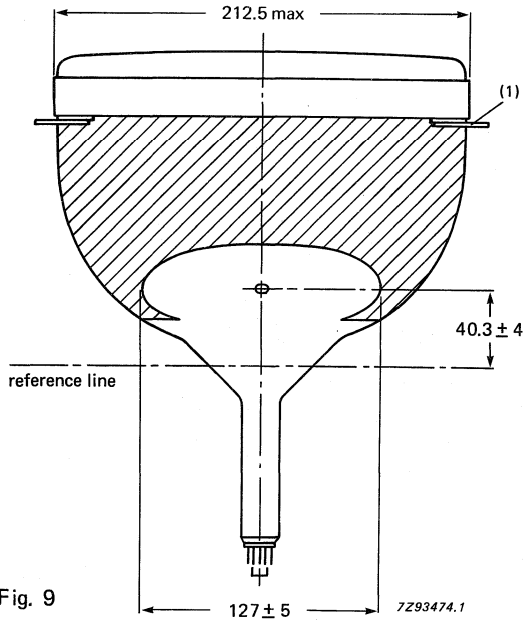

(1) The displacement of any lug with respect to the plane through the other three lugs is max. 2 mm.

Fig. 9

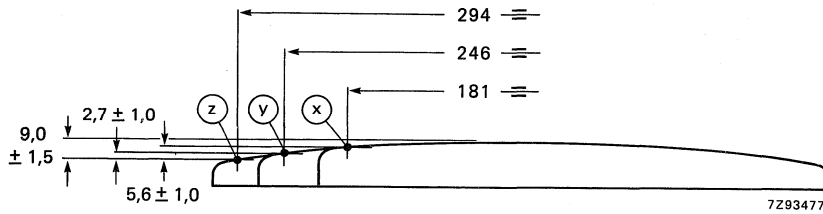

Fig. 10 Screen reference points.

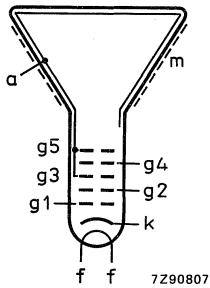

Fig. 11 Electrode configuration.

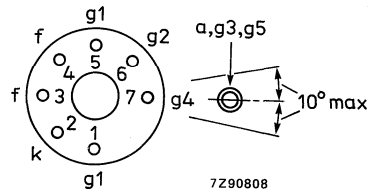

Fig. 12 Pin arrangement.

Front view of tube M29ECA

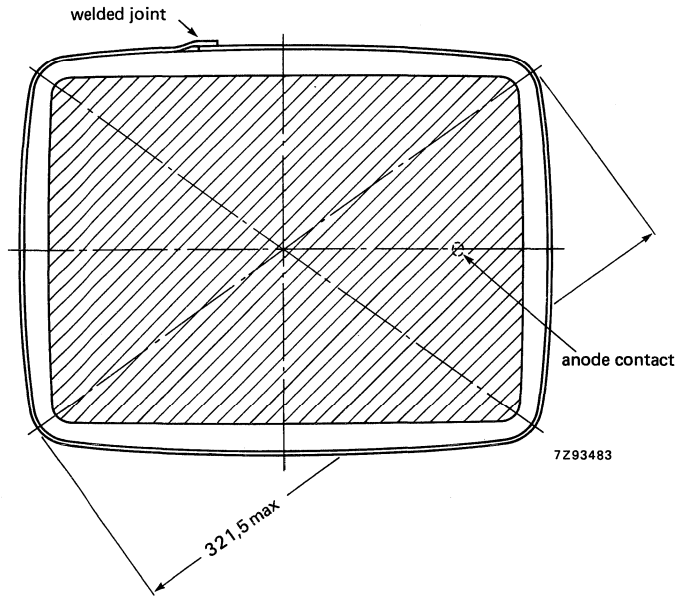

Fig. 13 Tube front view with rimband.

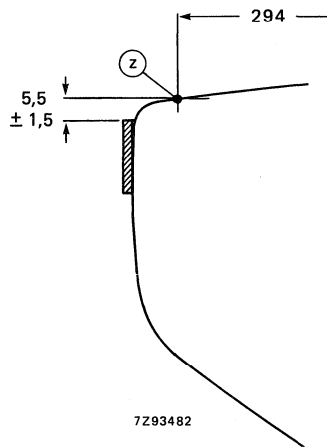

Fig. 14 Rimband position.

Front view and lug dimensions of tube M29ECB

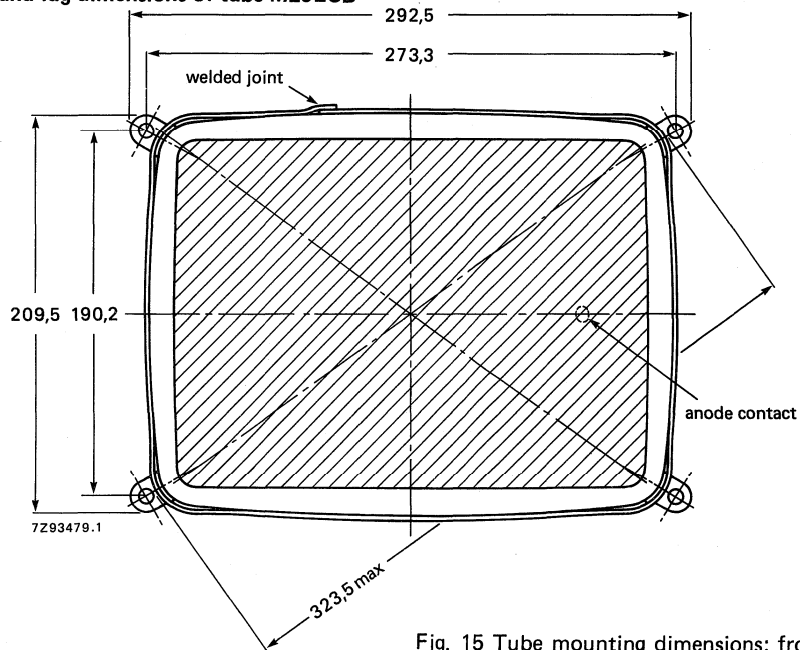

Fig. 15 Tube mounting dimensions; front view.

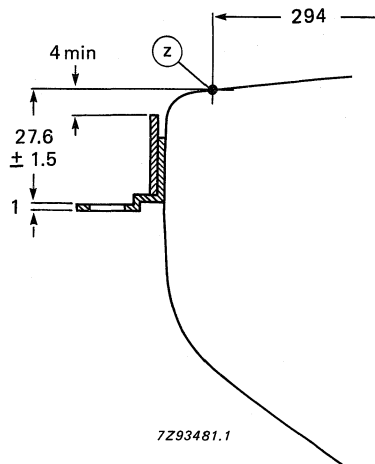

Fig. 16 Lug position.

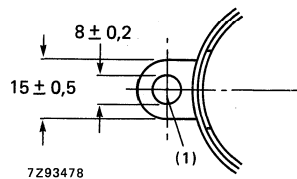

Fig. 17 Lug dimensions.

- (1) The mounting screws in the cabinet must be situated inside a circle of 5 mm diameter drawn around the true geometrical positions i.e. at the corners of a rectangle of 273,3 mm x 190,2 mm.

Maximum cone contour

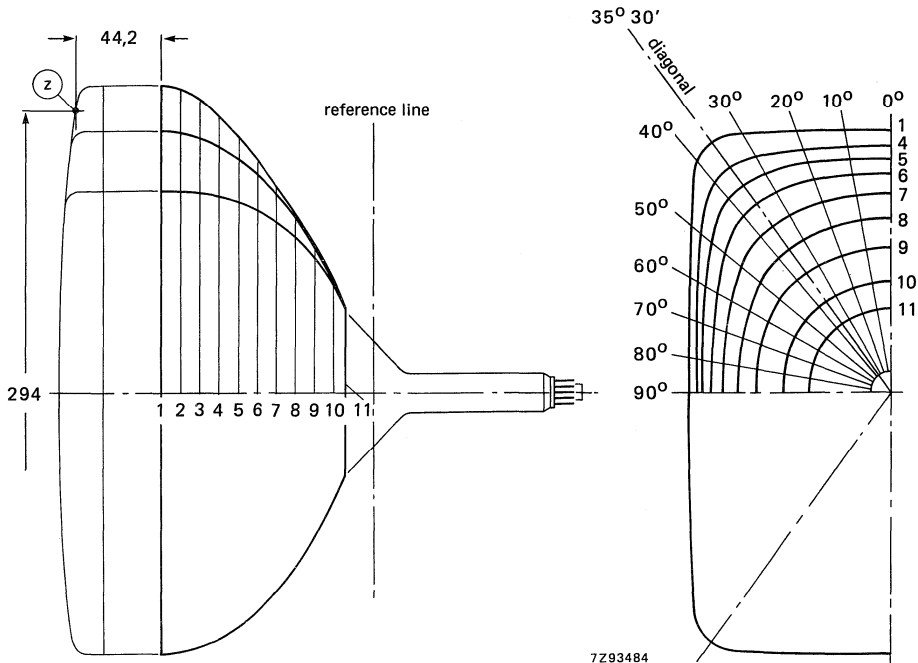

Fig. 18 Cone contour.

Table 1 Cone contour data

sec- tion	nom. distance from section 1	max. distance from centre										
		0°	10°	20°	30°	diag.	40°	50°	60°	70°	80°	90°
1	0	136,4	138,3	144,5	155,6	160,5	157,5	135,6	120,8	111,8	106,8	105,3
2	10	135,5	137,4	143,5	154,1	158,6	155,8	135,2	120,6	111,6	106,7	105,1
3	20	132,7	134,6	140,4	149,7	153,2	151,1	133,6	119,4	110,6	105,8	104,3
4	30	128,2	129,9	135,0	142,0	144,0	142,3	129,3	116,6	108,4	103,9	102,4
5	40	121,8	123,3	127,3	132,0	132,8	131,5	122,5	112,2	104,8	100,6	99,3
6	50	113,6	114,8	117,7	120,4	120,6	119,5	113,5	105,7	99,5	95,8	94,6
7	60	103,3	104,2	105,9	107,1	106,9	106,1	102,2	96,9	92,2	89,1	88,1
8	70	90,7	91,2	92,1	92,5	92,2	91,7	89,4	86,2	83,1	80,8	80,0
9	80	75,3	75,7	76,3	76,6	76,6	76,5	75,6	74,0	72,3	71,0	70,4
10	90	57,7	57,7	57,7	57,7	57,6	57,6	57,4	57,2	57,0	56,8	56,6
11	96,5	44,7	44,7	44,7	44,7	44,7	44,7	44,7	44,7	44,7	44,7	44,7

HIGH RESOLUTION MONOCHROME MONITOR TUBES

- For Data Graphic Displays
- 90° deflection angle
- 31 cm (12 in) face diagonal; rectangular glass
- 4:5 screen aspect ratio
- 510 mm radius of screen curvature
- 20 mm neck diameter
- Integral implosion protection

QUICK REFERENCE DATA

Deflection angle	90°
Face diagonal	31 cm (12 in)
Overall length	max. 280 mm
Neck diameter	20 mm
Heating	12 V/130 mA
Quick heating cathode	with a typical tube a legible picture will appear within 5 s
Grid 2 voltage	700 V
Anode voltage	12 kV
Resolution	approx. 1300 lines

APPLICATION

These high resolution tubes are for alpha-numeric and graphic display applications, such as computer terminals, small business computers, etc.

AVAILABLE VERSIONS

The following versions are available: M31-336, M31-338 and M31-350. Differences between the tubes can be found under 'Dimensional data'.

The tubes can be supplied with different phosphors and anti-reflective treatments, see "High resolution monochrome monitor tubes, General".

ELECTRICAL DATA

Focusing method	electrostatic
Deflection method	magnetic
Deflection angles	
diagonal	approx. 90°
horizontal	approx. 83°
vertical	approx. 65°
Direct interelectrode capacitances	
cathode to all other electrodes	max. 5 pF
grid 1 to all other electrodes	max. 7 pF
Capacitance of external conductive coating to anode*	max. 1050 pF min. 450 pF
Capacitance of external conductive coating to anode**	max. 900 pF min. 450 pF
Capacitance of anode to implosion protection hardware**	approx. 150 pF
Heater voltage	12 V
Heater current at 12 V	130 mA

OPTICAL DATA

Phosphor type	see "High resolution monochrome monitor tubes, General"
Light transmission at screen centre	
tube with normal tinted face glass	approx. 50%
tube with dark tinted face glass	approx. 34%

RASTER CENTRING

The field intensity perpendicular to the tube axis should be adjustable from 0 to 800 A/m. For optimum overall sharpness it is recommended to centre the raster electrically via the deflection coils.

* Implosion protection hardware connected to external conductive coating.

** Implosion protection hardware not connected to external conductive coating.

MECHANICAL DATA (see also the figures under Dimensional Data)

Overall length	max.	280 mm
Greatest dimensions of tube		
diagonal		315 mm
width		279 mm
height		227 mm
Minimum useful screen dimensions (projected)		
diagonal		292 mm
horizontal axis		254 mm
vertical axis		201 mm
area		484 cm ²
Implosion protection		T-band
Bulb		EIAJ-JB310AM03 or EIAJ-JB310AW04
Bulb contact designation		IEC 67-III-2, EIA-J1-21
Base designation		EIA E7-91
Basing		7GR
Mass		approx. 2,9 kg

RATINGS (Absolute Maximum System)

Unless otherwise specified voltage values are positive and measured with respect to grid 1.

Anode voltage	max.	15 kV
	min.	10 kV
Grid 4 (focusing electrode) voltage		-200 to +1000 V
Grid 2 voltage	max.	1000 V
	min.	400 V
Anode current		
	long-term average value	max.
peak value	max.	300 μ A
Cathode voltage, positive peak value	max.	400 V
Heater voltage		12 V +5/-10%*
Cathode-to-heater voltage	max.	100 V

* For maximum cathode life it is recommended that the heater supply be regulated at 12 V $\begin{matrix} +0\% \\ -5\% \end{matrix}$.

CIRCUIT DESIGN VALUES

Grid 4 current	
positive	max. 25 μ A
negative	max. 25 μ A
Grid 2 current	
positive	max. 5 μ A
negative	max. 5 μ A

MAXIMUM CIRCUIT VALUES

Resistance between cathode and heater	max. 1,0 M Ω
Impedance between cathode and heater	max. 0,1 M Ω
Grid 1 circuit resistance	max. 1,5 M Ω
Grid 1 circuit impedance	max. 0,5 M Ω

TYPICAL OPERATING CONDITIONS

Cathode drive; voltages specified with respect to grid 1

Anode voltage	12 kV
Grid 4 (focusing electrode) voltage	0 to 300 V*
Grid 2 voltage	700 V
Cathode cut-off voltage	57 to 97 V**

Grid drive; voltages specified with respect to cathode

Anode voltage	12 kV
Grid 4 (focusing electrode) voltage	0 to 300 V*
Grid 2 voltage	700 V.
Grid 1 cut-off voltage	65 to 107 V**

RESOLUTION

The resolution is approx. 1300 lines. It is measured at the screen centre:

- with shrinking raster method,
- at light output 68,5 cd/m² (20 foot lambert) and raster dimensions 216 mm x 162 mm,
- at $V_{g2} = 700$ V and anode voltage = 12 kV,
- with phosphor type W (WW),
- with normal tinted face glass, without anti-glare treatment of screen surface.

X-RADIATION CHARACTERISTIC

X-radiation emitted will not exceed 0,5 mR/h throughout the useful life of the tube, when operated within the given ratings.

* Measured at screen centre on spot at anode current = 250 μ A (peak), anode voltage = 12 kV, grid 2 voltage = 700 V.

Dynamic focus (only for optimization): Typical correction for a video field of H x V = 216 mm x 162 mm:
line parabola 200 V,
field parabola 100 V.

** Visual extinction of focused raster.

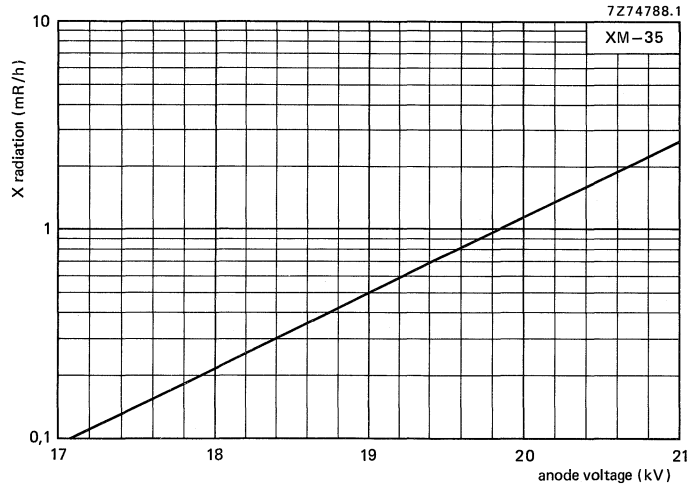

Fig. 1 X-radiation limit curve according to JEDEC94, at a constant anode current of 250 μ A, measured according to TEPAC103A.

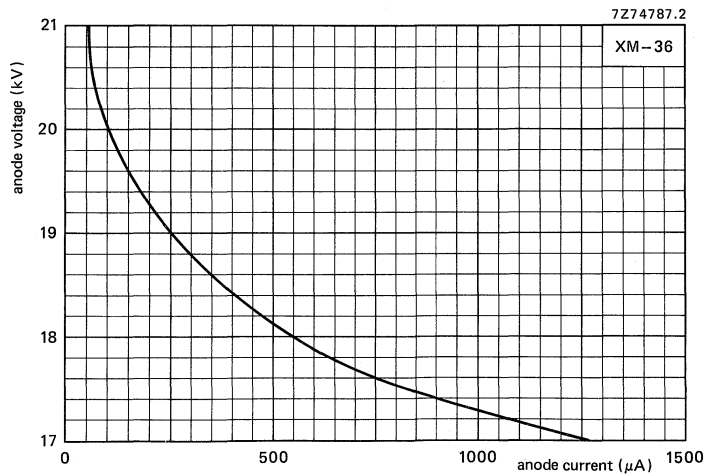

Fig. 2 0,5 mR/h isoexposure-rate limit curve, according to JEDEC94, measured according to TEPAC103A.

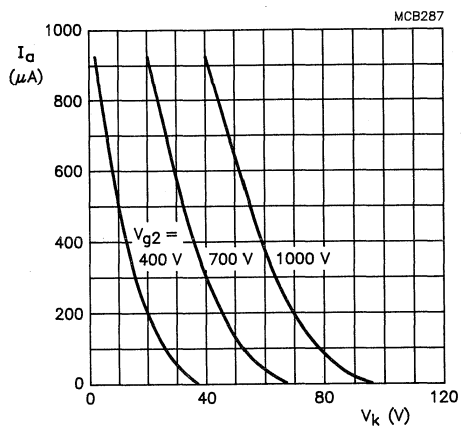

Fig. 3 Anode current as a function of cathode voltage.
Cathode drive; $V_{a,g3,g5} = 12$ kV.

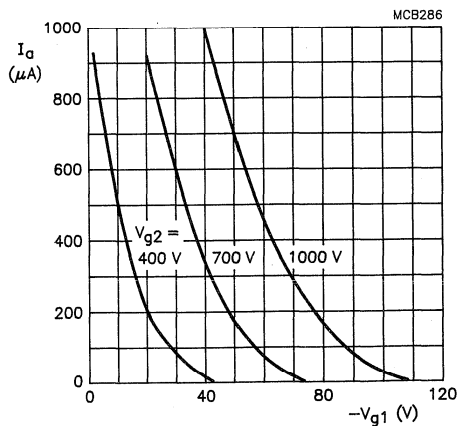

Fig. 4 Anode current as a function of grid 1 voltage.
Grid drive; $V_{a,g3,g5} = 12$ kV.

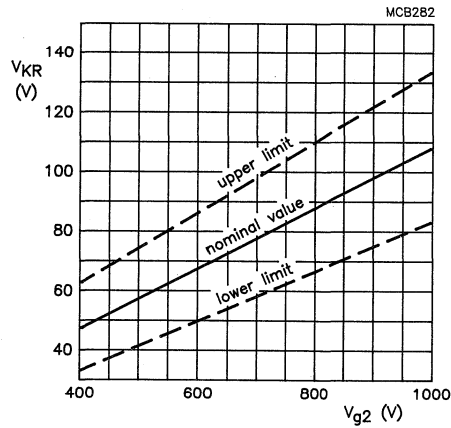

Fig. 5 Limits of cathode cut-off voltage as a function of grid 2 voltage.
Cathode drive; $V_{a,g3,g5} = 12$ kV.

$$\frac{\Delta V_{KR}}{\Delta V_{a,g3,g5}} = 0.9 \times 10^{-3}$$

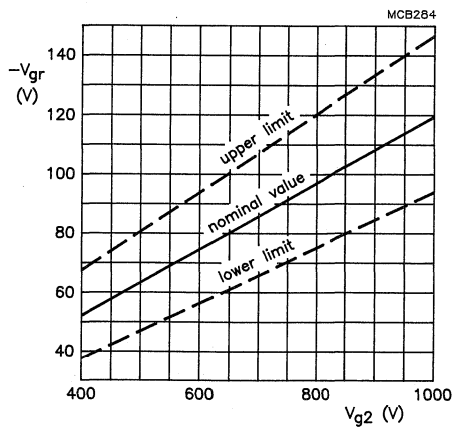

Fig. 6 Limits of grid 1 cut-off voltage as a function of grid 2 voltage.
Grid drive; $V_{a,g3,g5} = 12$ kV.

$$\frac{\Delta V_{GR}}{\Delta V_{a,g3,g5}} = 0.9 \times 10^{-3}$$

DIMENSIONAL DATA

Dimensions in mm

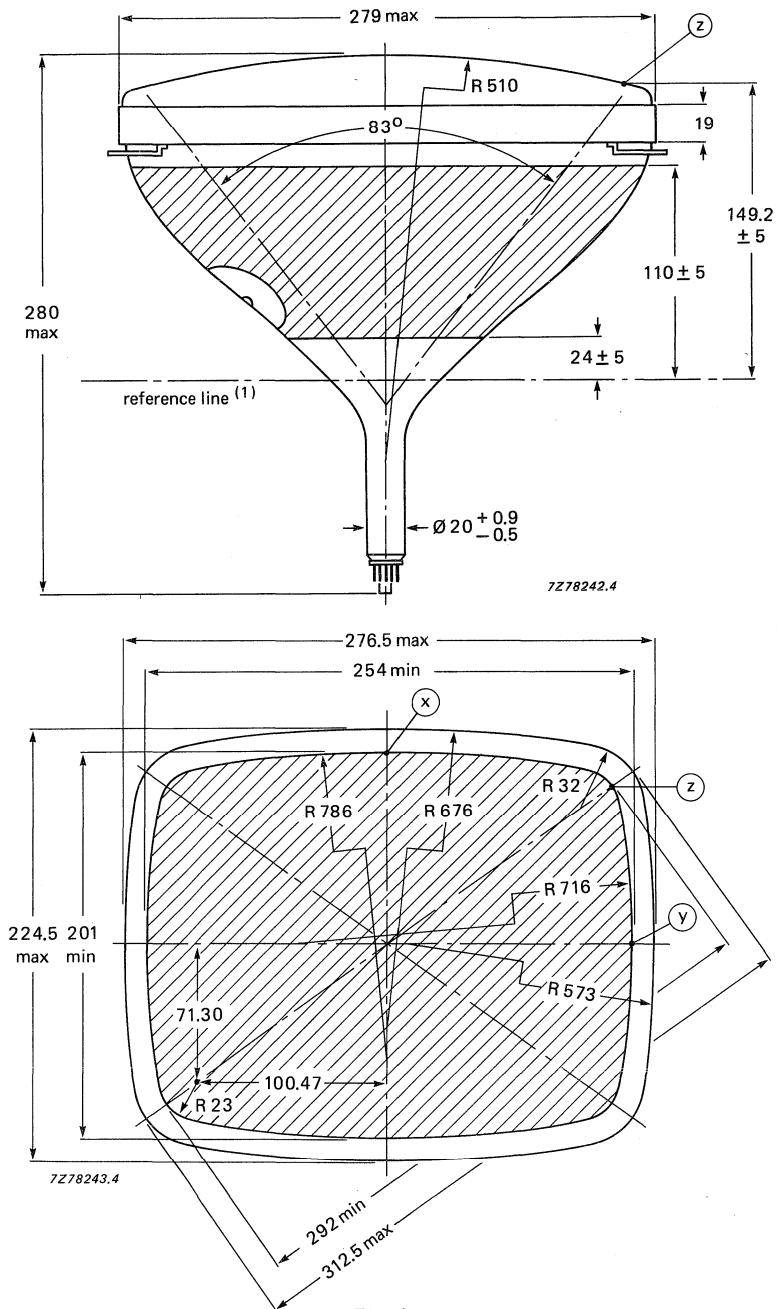

Fig. 8

(1) The reference line is determined by the plane of the upper edge of reference line gauge D when the gauge is resting on the cone.

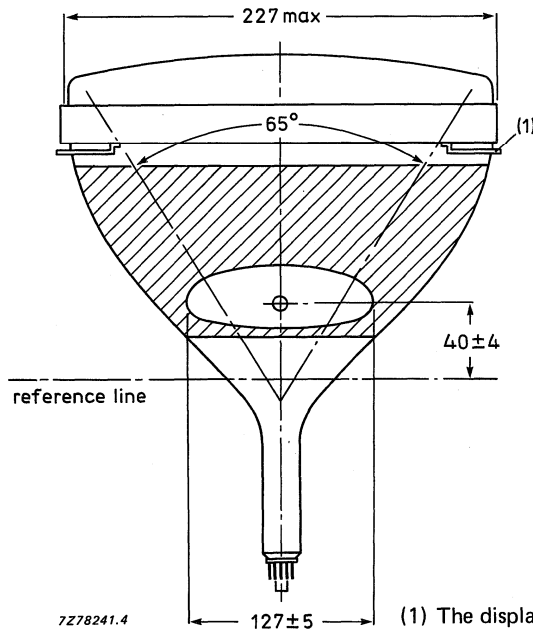

Fig. 9

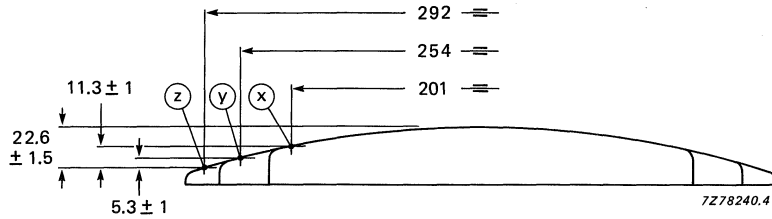

Fig. 10 Screen reference points.

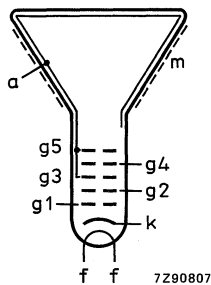

Fig. 11 Electrode configuration

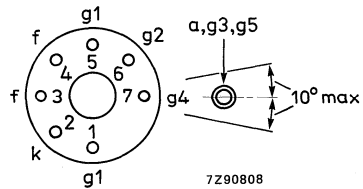

Fig. 12 Pin arrangement.

Front view and lug dimensions of tube M31-336

Dimensions in mm

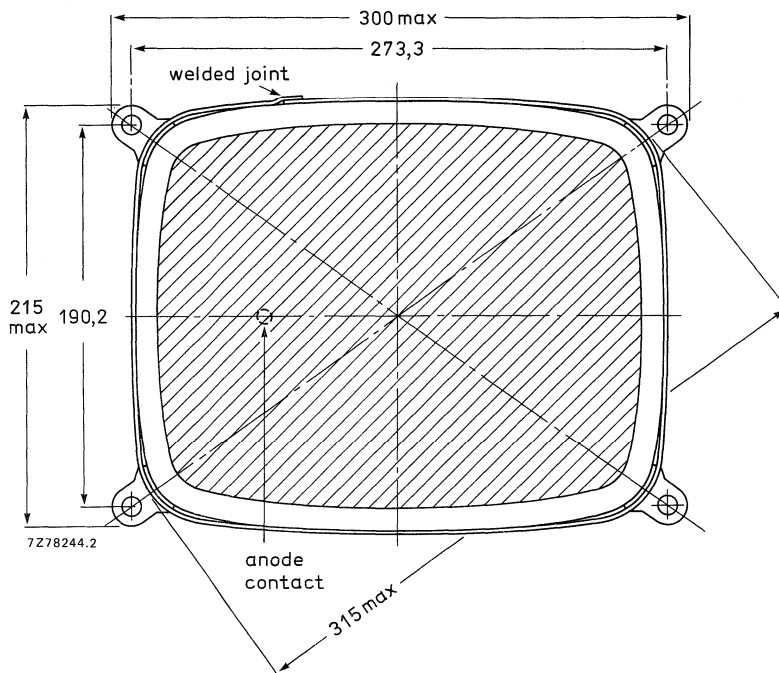

Fig. 13 Tube mounting dimensions; front view

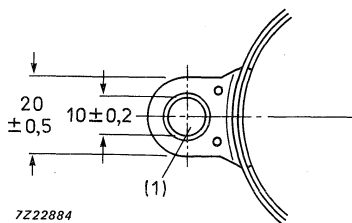

Fig. 14 Lug dimensions.

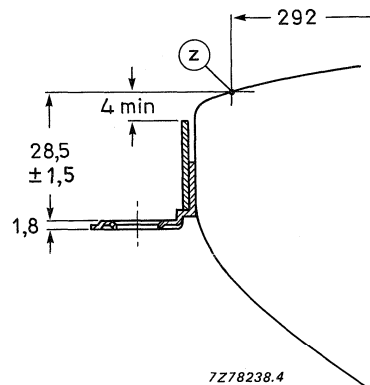

Fig. 15 Lug position.

(1) The position of the mounting screws in the cabinet must be within a circle of 7 mm diameter drawn around the true geometrical positions, i.e. the corners of a rectangle of 273,3 mm x 190,2 mm.

Front view and lug dimensions of tube M31-338

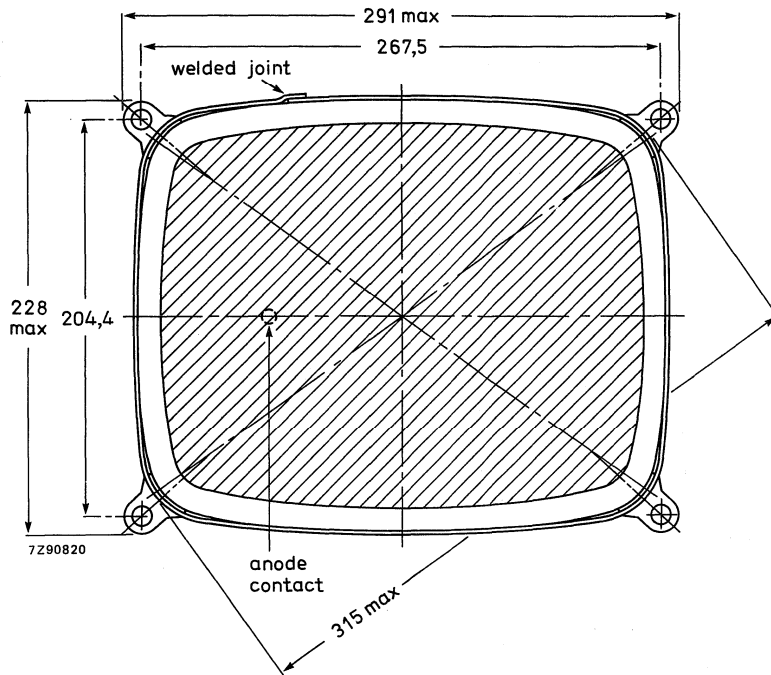

Fig. 16 Tube mounting dimensions; front view

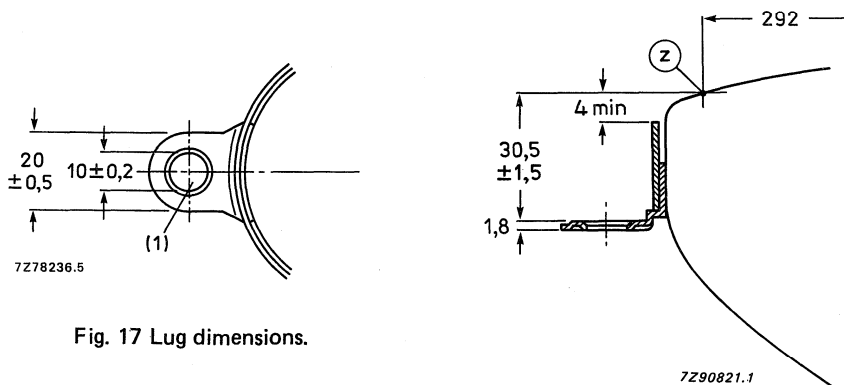

Fig. 17 Lug dimensions.

Fig. 18 Lug position.

(1) The position of the mounting screws in the cabinet must be within a circle of 7 mm diameter drawn around the true geometrical positions, i.e. corners of a rectangle of 267,5 mm x 204,4 mm.

Front view of tube M31-350

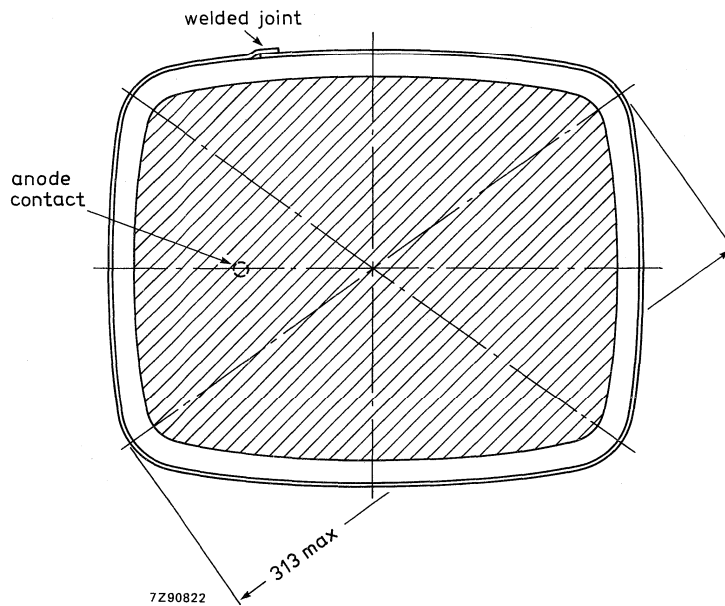

Fig. 19 Tube front view with rimband.

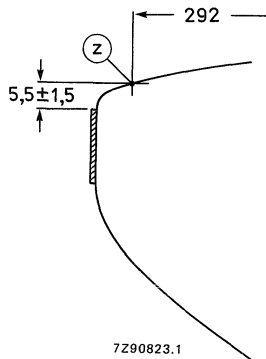

Fig. 20 Rimband position.

Maximum cone contour

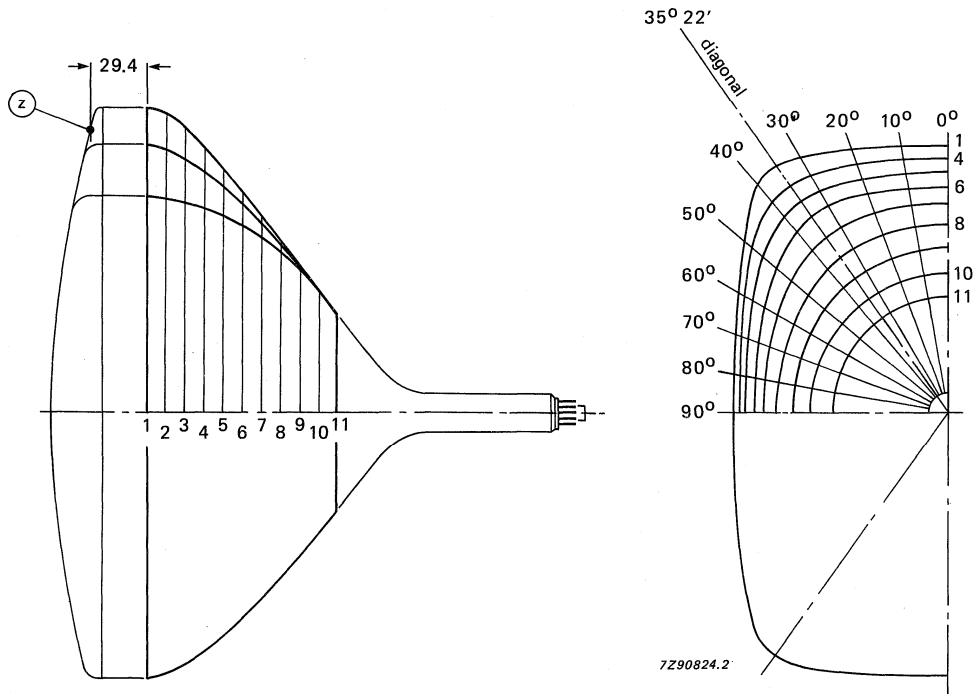

Fig. 21 Cone contour.

Table 1 Cone contour data

sec- tion	nom. distance from section 1	max. distance from centre										
		0°	10°	20°	30°	diag.	40°	50°	60°	70°	80°	90°
1	0	138,3	139,9	145,0	153,9	156,6	154,7	138,9	126,3	118,2	113,7	112,3
2	10	136,5	138,1	143,2	151,5	154,4	152,6	137,5	125,0	116,9	112,4	110,9
3	20	131,8	133,4	138,1	145,1	147,5	146,2	133,8	122,1	114,3	110,0	108,6
4	30	125,2	126,6	130,6	136,0	137,5	136,6	127,9	117,8	110,7	106,6	105,3
5	40	117,0	118,2	121,3	124,8	125,6	125,0	119,6	112,1	106,1	102,5	101,3
6	50	107,9	108,8	111,0	113,1	113,5	113,2	110,2	105,2	100,6	97,6	96,6
7	60	98,1	98,7	100,0	101,1	101,3	101,2	99,8	97,2	94,3	92,0	91,2
8	70	87,7	88,0	88,5	89,0	89,1	89,1	88,8	87,9	86,6	85,5	84,9
9	80	76,6	76,5	76,5	76,6	76,8	76,9	77,1	77,3	77,4	77,3	77,2
10	90	64,6	64,4	64,1	64,1	64,2	64,3	64,8	65,5	66,3	66,9	67,3
11	99	51,1	51,1	51,1	51,1	51,1	51,1	51,1	51,1	51,1	51,1	51,1

HIGH RESOLUTION MONOCHROME MONITOR TUBES

- For Data Graphic Displays
- 90° deflection angle
- 31 cm (12 in) face diagonal; rectangular glass
- 3: 4 screen aspect ratio
- 635 mm radius of screen curvature
- 20 mm neck diameter
- Integral implosion protection

QUICK REFERENCE DATA

Deflection angle	90°
Face diagonal	31 cm (12 in)
Overall length	max. 277 mm
Neck diameter	20 mm
Heating	12 V/130 mA
Quick heating cathode	with a typical tube a legible picture will appear within 5 s
Grid 2 voltage	700 V
Anode voltage	12 kV
Resolution	approx. 1300 lines

APPLICATION

These high resolution tubes are for alpha numeric and graphic display applications, such as computer terminals, small business computers, etc.

AVAILABLE VERSIONS

The following versions are available: M31-340, M31-342, M31-344, M31346 and M31-348.

The tubes can be supplied with different phosphors and anti-reflective treatments, see "High resolution monochrome monitor tubes, General".

Differences between the tubes can be found under 'Dimensional data'.

ELECTRICAL DATA

Focusing method	electrostatic
Deflection method	magnetic
Deflection angles	
diagonal	approx. 90°
horizontal	approx. 78°
vertical	approx. 61°
Interelectrode capacitances	
cathode to all other electrodes	max. 5 pF
grid 1 to all other electrodes	max. 7 pF
Capacitance of external conductive coating to anode*	max. 1200 pF min. 450 pF
Capacitance of external conductive coating to anode**	max. 1050 pF min. 450 pF
Capacitance of anode to implosion protection hardware**	approx. 150 pF
Heater voltage	12 V
Heater current at 12 V	130 mA

OPTICAL DATA

Phosphor type	see "High resolution monochrome monitor tubes, General"
Light transmission at screen centre	
tube with normal tinted face glass	approx. 46%
tube with dark tinted face glass	approx. 34%

RASTER CENTRING

The field intensity perpendicular to the tube axis should be adjustable from 0 to 800 A/m. For optimum overall sharpness it is recommended to centre the raster electrically via the deflection coils.

* Implosion protection hardware connected to external conductive coating.

** Implosion protection hardware not connected to external conductive coating.

MECHANICAL DATA (see also the figures under Dimensional Data)

Overall length	max. 277 mm
Greatest dimensions of tube	
diagonal	321 mm
width	283 mm
height	222 mm
Minimum useful screen dimensions (projected)	
diagonal	294 mm
horizontal axis	257 mm
vertical axis	195 mm
area	478 cm ²
Implosion protection	T-band
Bulb	EIAJ-JB310AP03 or EIAJ-JB310AP04
Bulb contact designation	IEC 67-III-2, EIAJ1-21
Base designation	EIA E7-91
Basing	7GR
Mass	approx. 2,9 kg

RATINGS (Absolute Maximum System)

Unless otherwise specified voltage values are positive and measured with respect to grid 1.

Anode voltage	max. 15 kV min. 10 kV
Grid 4 (focusing electrode) voltage	-200 to + 1000 V
Grid 2 voltage	max. 1000 V min. 400 V
Anode current	
long-term average value	max. 130 μ A
peak value	max. 300 μ A
Cathode voltage, positive peak value	max. 400 V
Heater voltage	12 V +5/-10%*
Cathode-to-heater voltage	max. 100 V

* For maximum cathode life it is recommended that the heater supply be regulated at 12 V $\begin{matrix} +0\% \\ -5\% \end{matrix}$.

CIRCUIT DESIGN VALUES

Grid 4 current	
positive	max. 25 μ A
negative	max. 25 μ A
Grid 2 current	
positive	max. 5 μ A
negative	max. 5 μ A

MAXIMUM CIRCUIT VALUES

Resistance between cathode and heater	max. 1,0 $M\Omega$
Impedance between cathode and heater	max. 0,1 $M\Omega$
Grid 1 circuit resistance	max. 1,5 $M\Omega$
Grid 1 circuit impedance	max. 0,5 $M\Omega$

TYPICAL OPERATING CONDITIONS

Cathode drive; voltages specified with respect to grid 1

Anode voltage	12 kV
Grid 4 (focusing electrode) voltage	0 to 300 V*
Grid 2 voltage	700 V
Cathode cut-off voltage	57 to 97 V**

Grid drive; voltages specified with respect to cathode

Anode voltage	12 kV
Grid 4 (focusing electrode) voltage	0 to 300 V*
Grid 2 voltage	700 V
Grid 1 cut-off voltage	65 to 107 V**

RESOLUTION

The resolution is approx. 1300 lines. It is measured at the screen centre:

- with shrinking raster method,
- at light output 68,5 cd/m² (20 foot lambert) and raster dimensions 216 x 162 mm,
- at $V_{g2} = 700$ V and anode voltage = 12 kV,
- with phosphor type W (WW),
- with normal tinted face glass, without anti-glare treatment of screen surface.

X-RADIATION CHARACTERISTIC

X-radiation emitted will not exceed 0,5 mR/h throughout the useful life of the tube, when operated within the given ratings.

* Measured at screen centre on spot at anode current = 250 μ A (peak), anode voltage = 12 kV, grid 2 voltage = 700 V.

Dynamic focus (only for optimization): Typical correction for a video field of $H \times V = 216$ mm x 162 mm:
line parabola 200 V,
field parabola 100 V.

** Visual extinction of focused raster.

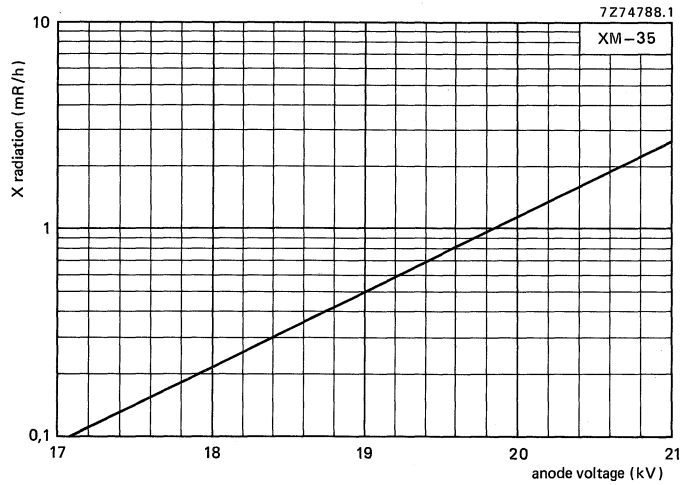

Fig. 1 X-radiation limit curve according to JEDEC94, at a constant anode current of 250 μ A, measured according to TEPAC103A.

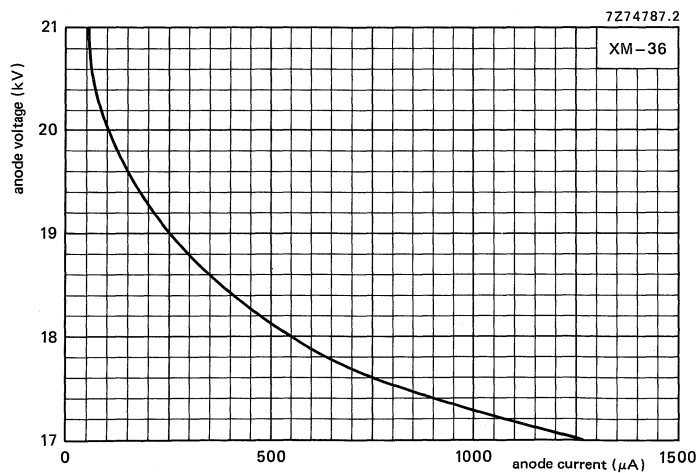

Fig. 2 0,5 mR/h isoexposure-rate limit curve, according to JEDEC94, measured according to TEPAC103A.

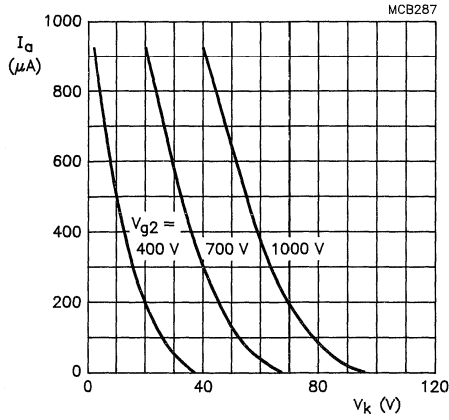

Fig. 3 Anode current as a function of cathode voltage.
Cathode drive; $V_{a,g3,g5} = 12$ kV.

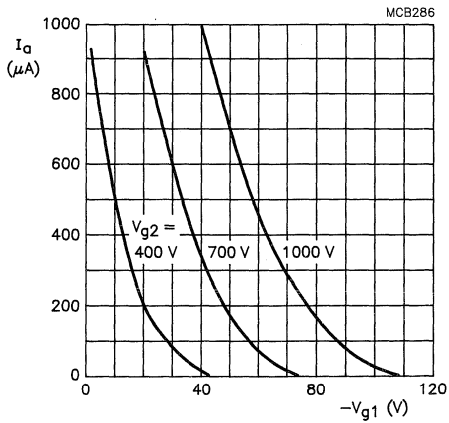

Fig. 4 Anode current as a function of grid 1 voltage.
Grid drive; $V_{a,g3,g5} = 12$ kV.

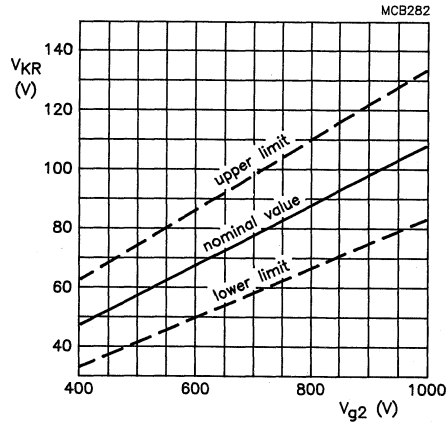

Fig. 5 Limits of cathode cut-off voltage as a function of grid 2 voltage.
Cathode drive; $V_{a,g3,g5} = 12$ kV.

$$\frac{\Delta V_{KR}}{\Delta V_{a,g3,g5}} = 0.9 \times 10^{-3}$$

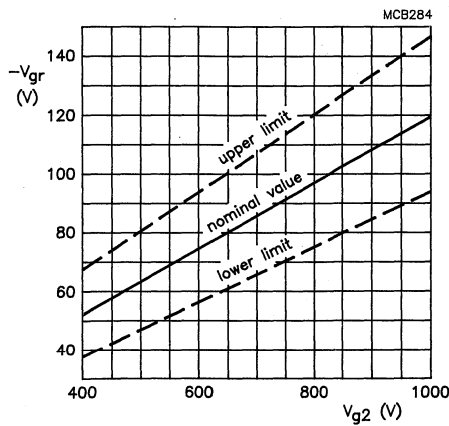

Fig. 6 Limits of grid 1 cut-off voltage as a function of grid 2 voltage.
Grid drive; $V_{a,g3,g5} = 12$ kV.

$$\frac{\Delta V_{GR}}{\Delta V_{a,g3,g5}} = 0.9 \times 10^{-3}$$

DIMENSIONAL DATA

Dimensions in mm

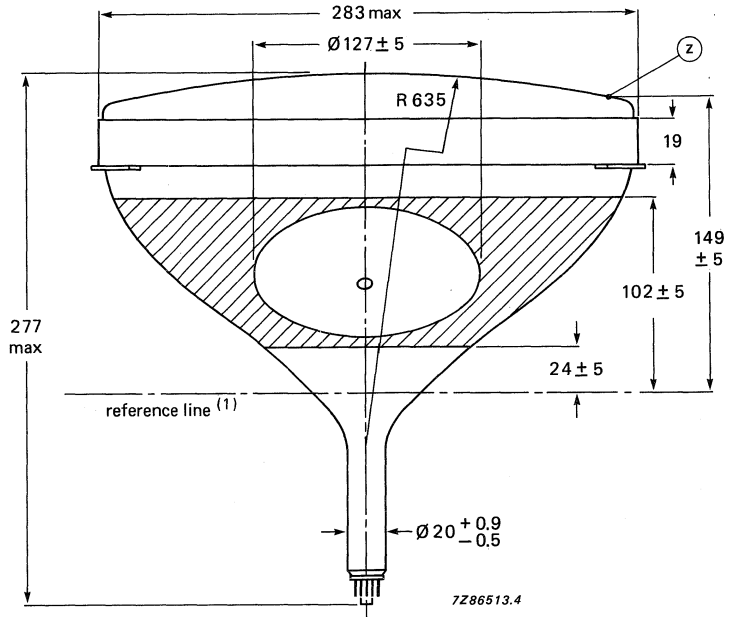

Fig. 7

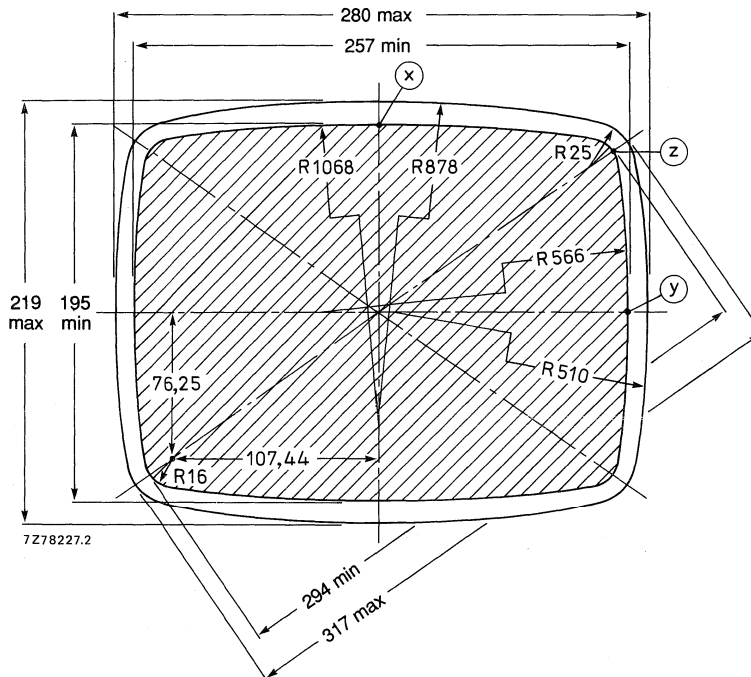

Fig. 8

(1) The reference line is determined by the plane of the upper edge of reference line gauge D when the gauge is resting on the cone.

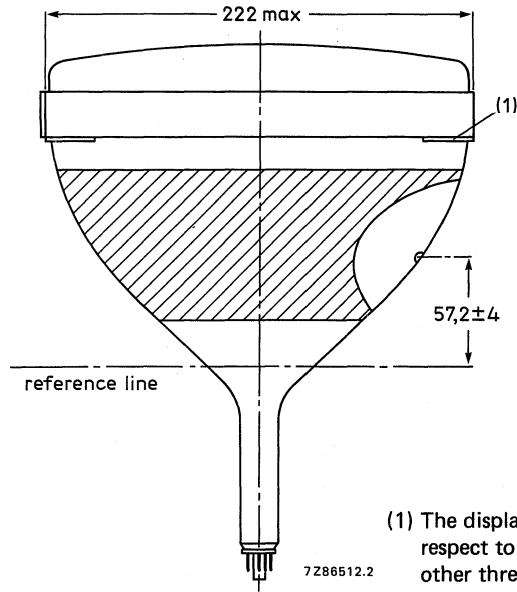

Fig. 9

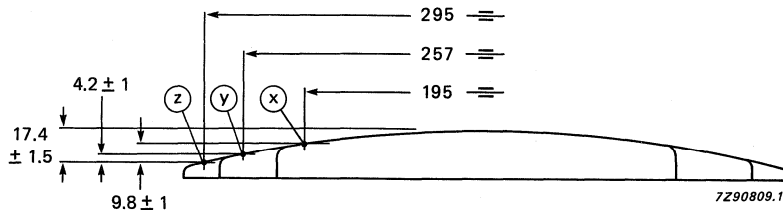

Fig. 10 Screen reference points.

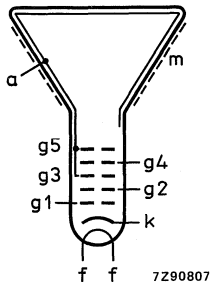

Fig. 11 Electrode configuration.

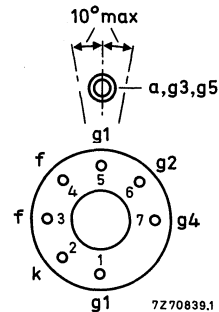

Fig. 12 Pin arrangement.

Front view and lug dimensions of tube M31-340

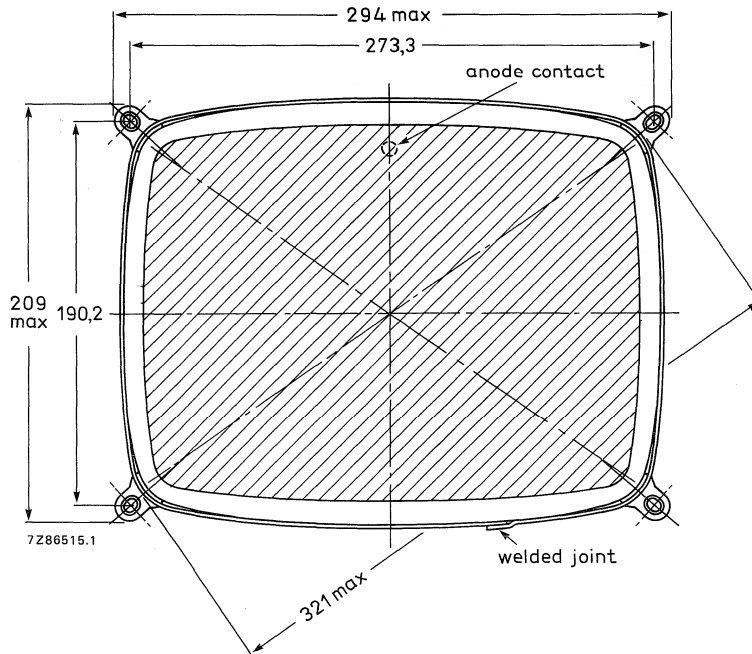

Fig. 13 Tube mounting dimensions; front view.

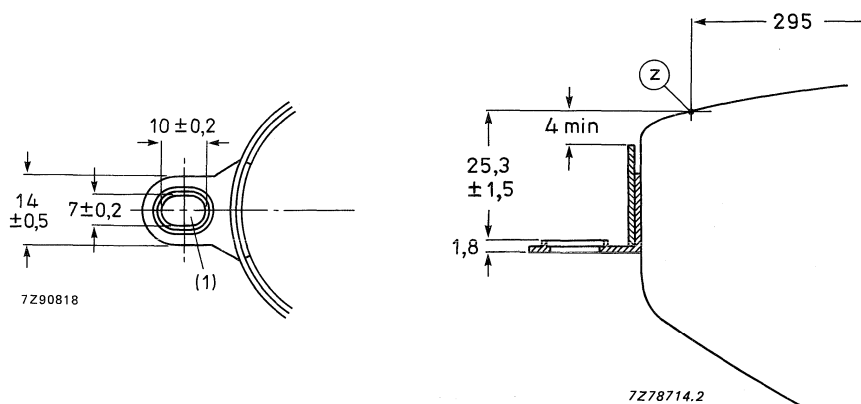

Fig. 14 Lug dimensions.

Fig. 15 Lug position.

(1) The mounting screws in the cabinet must be situated inside a circle of 4 mm diameter drawn around the true geometrical positions i.e. at the corners of a rectangle of 273.3 mm x 190.2 mm.

Front view and lug dimensions of tube M31-342

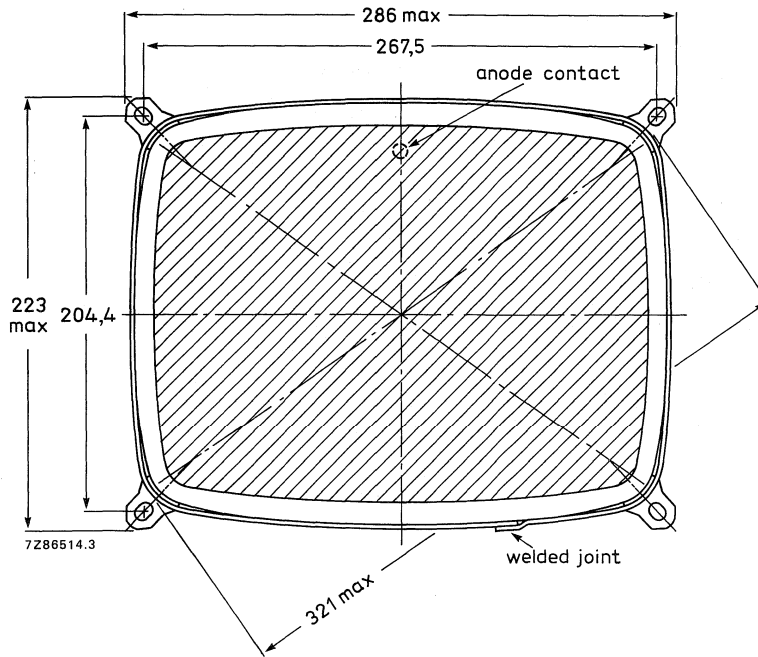

Fig. 16 Tube mounting dimensions; front view.

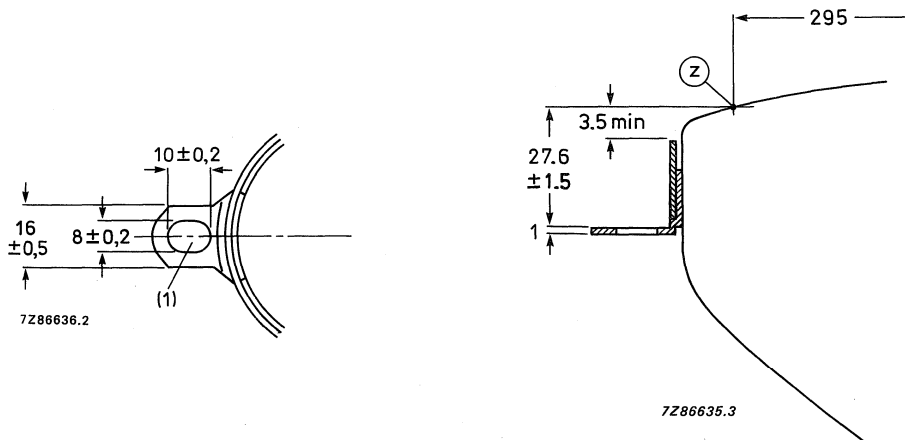

Fig. 17 Lug dimensions.

Fig. 18 Lug position.

(1) The mounting screws in the cabinet must be situated inside a circle of 5 mm diameter drawn around the true geometrical positions i.e. at the corners of a rectangle of 267.5 mm x 204.4 mm.

Front view of tube M31-344

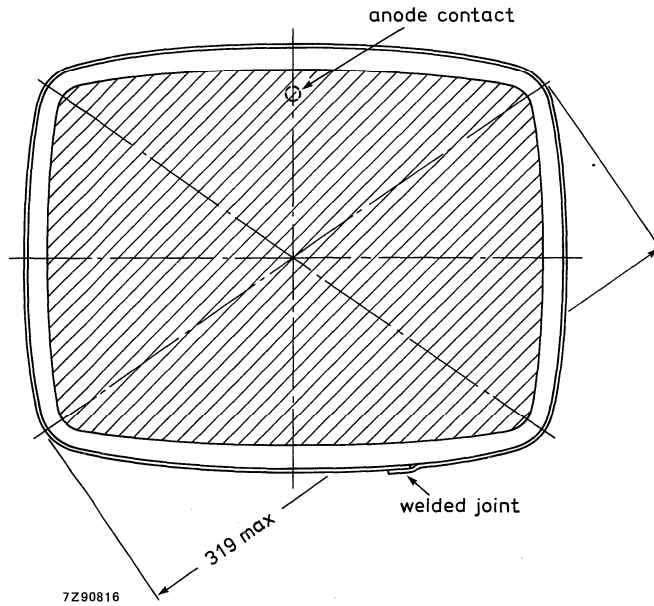

Fig. 19 Tube front view with rimband.

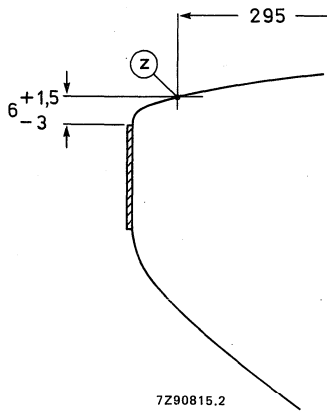

Fig. 20 Rimband position.

Front view and lug dimensions of tube M31-346

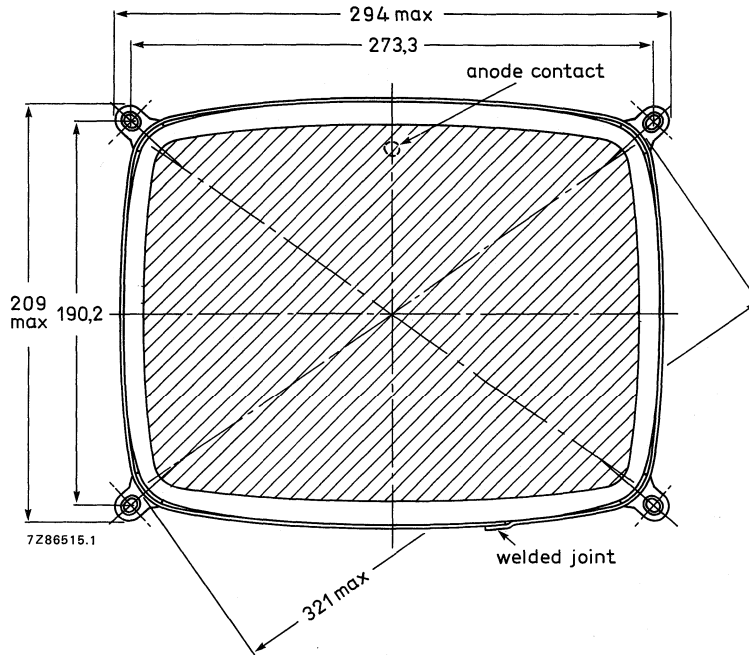

Fig. 21 Tube mounting dimensions; front view.

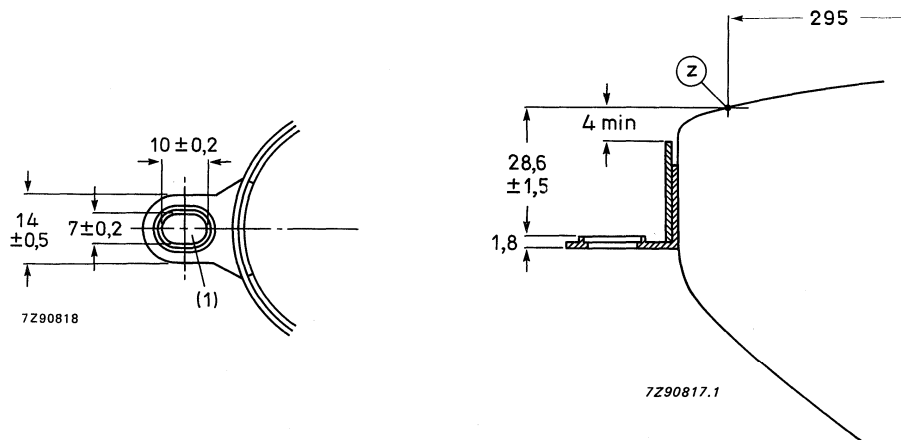

Fig. 22 Lug dimensions.

Fig. 23 Lug position.

(1) The mounting screws in the cabinet must be situated inside a circle of 4 mm diameter drawn around the true geometrical positions i.e. at the corners of a rectangle of 273.3 mm x 190.2 mm.

Front view and lug dimensions of tube M31-348

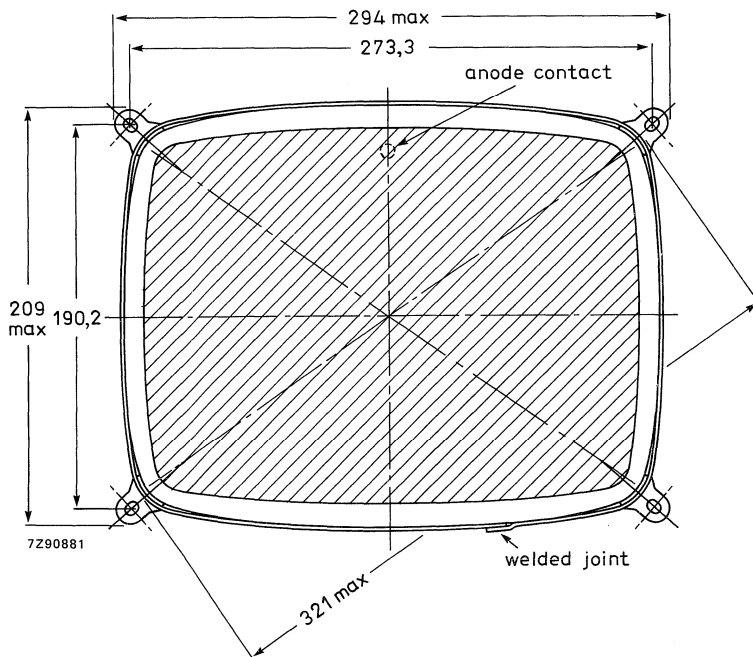

Fig. 24 Tube mounting dimensions; front view.

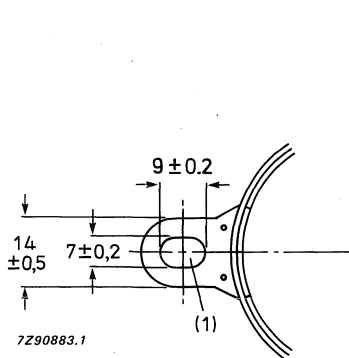

Fig. 25 Lug dimensions.

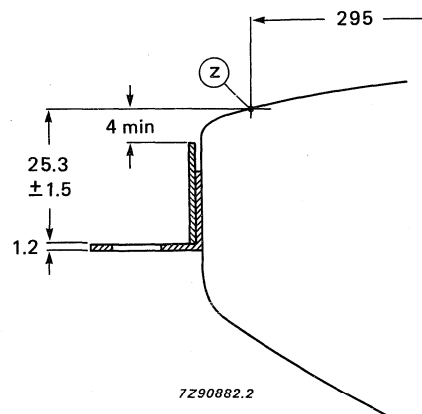

Fig. 26 Lug position.

(1) The mounting screws in the cabinet must be situated inside a circle of 4 mm diameter drawn around the true geometrical positions i.e. at the corners of a rectangle of 273.3 mm x 190.2 mm.

Maximum cone contour

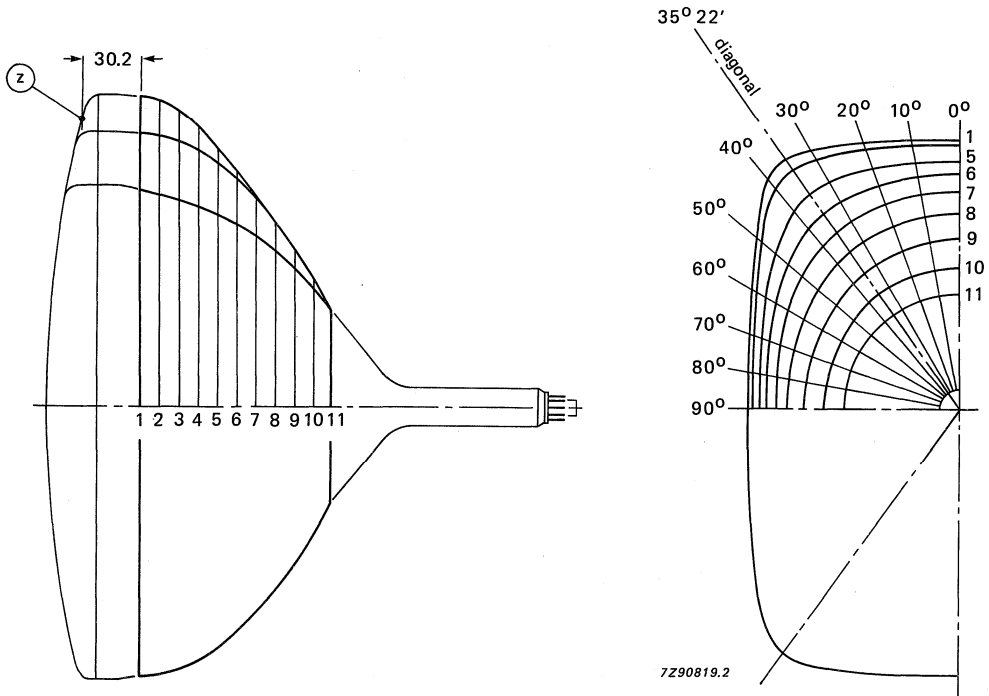

Fig. 27 Cone contour.

Table 1 Cone contour data

sec- tion	nom. distance from section 1	max. distance from centre										
		0°	10°	20°	30°	diag.	40°	50°	60°	70°	80°	90°
1	0	140,6	142,4	147,9	156,8	160,4	156,9	139,3	126,1	117,5	112,7	111,2
2	10	139,8	141,6	147,0	155,5	158,5	154,4	136,8	123,7	115,2	110,5	109,0
3	20	137,8	139,4	144,4	151,9	153,6	149,5	133,0	120,4	112,3	107,8	106,4
4	30	133,5	135,0	139,3	144,8	145,1	141,6	127,7	116,3	108,7	104,5	103,1
5	40	126,9	128,1	131,3	134,2	133,6	130,9	120,7	110,9	104,2	100,4	99,1
6	50	117,9	118,8	120,9	122,1	121,1	119,2	112,1	104,5	98,7	95,3	94,2
7	60	107,2	107,9	109,1	109,3	108,5	107,1	102,3	96,8	92,1	89,1	88,1
8	70	95,5	95,9	96,4	96,0	95,2	94,2	91,2	87,5	84,1	81,8	80,9
9	80	82,4	82,5	82,4	81,8	81,2	80,5	78,7	76,6	74,5	73,0	72,4
10	90	67,5	67,5	67,2	66,6	66,3	65,9	65,0	64,1	63,2	62,5	62,2
11	99	50,3	50,3	50,3	50,3	50,3	50,3	50,3	50,3	50,3	50,3	50,3

HIGH RESOLUTION MONOCHROME MONITOR TUBE

- For Data Graphic Displays
- 90° deflection angle
- 31 cm (12 in) face diagonal; rectangular glass
- 4:5 screen aspect ratio
- 510 mm radius of screen curvature
- 20 mm neck diameter
- Integral implosion protection

QUICK REFERENCE DATA

Deflection angle	90°
Face diagonal	31 cm (12 in)
Overall length	max. 280 mm
Neck diameter	20 mm
Heating	12 V/75 mA
Grid 2 voltage	700 V
Anode voltage	12 kV
Resolution	approx. 1300 lines

APPLICATION

This high resolution tube is for alpha-numeric and graphic display applications, such as computer terminals, small business computers, etc.

The tube can be supplied with different phosphors and anti-reflective treatments, see "High resolution monochrome monitor tubes, General".

ELECTRICAL DATA

Focusing method	electrostatic
Deflection method	magnetic
Deflection angles	
diagonal	approx. 90°
horizontal	approx. 83°
vertical	approx. 65°
Direct interelectrode capacitances	
cathode to all other electrodes	max. 5 pF
grid 1 to all other electrodes	max. 8 pF
Capacitance of external conductive coating to anode*	max. 1050 pF min. 450 pF
Capacitance of external conductive coating to anode**	max. 900 pF min. 450 pF
Capacitance of anode to implosion protection hardware**	approx. 150 pF
Heater voltage	12 V
Heater current at 12 V	75 mA

OPTICAL DATA

Phosphor type	see "High resolution monochrome monitor tubes, General"
Light transmission at screen centre	
tube with normal tinted face glass	approx. 50%
tube with dark tinted face glass	approx. 34%

RASTER CENTRING

The field intensity perpendicular to the tube axis should be adjustable from 0 to 800 A/m. For optimum overall sharpness it is recommended to centre the raster electrically via the deflection coils.

* Implosion protection hardware connected to external conductive coating.

** Implosion protection hardware not connected to external conductive coating.

MECHANICAL DATA (see also the figures under Dimensional Data)

Overall length	max. 280 mm
Greatest dimensions of tube	
diagonal	315 mm
width	279 mm
height	227 mm
Minimum useful screen dimensions (projected)	
diagonal	292 mm
horizontal axis	254 mm
vertical axis	201 mm
area	484 cm ²
Implosion protection	T-band
Bulb	EIAJ-JB310AM03 or EIAJ-JB310AW04
Bulb contact designation	IEC67-III-2, EIAJ1-21
Base designation	EIA E7-91
Basing	7GR
Mass	approx. 2,9 kg

RATINGS (Absolute Maximum System)

Unless otherwise specified voltage values are positive and measured with respect to grid 1.

Anode voltage	max. 15 kV min. 10 kV
Grid 4 (focusing electrode) voltage	-200 to + 1000 V
Grid 2 voltage	max. 1000 V min. 400 V
Anode current	
long-term average value	max. 130 μ A
peak value	max. 300 μ A
Cathode voltage, positive peak value	max. 400 V
Heater voltage	12 V +5/-10%*
Cathode-to-heater voltage	max. 100 V

* For maximum cathode life it is recommended that the heater supply be regulated at 12 V $\begin{matrix} +0\% \\ -5\% \end{matrix}$.

CIRCUIT DESIGN VALUES

Grid 4 current	
positive	max. 25 μ A
negative	max. 25 μ A
Grid 2 current	
positive	max. 5 μ A
negative	max. 5 μ A

MAXIMUM CIRCUIT VALUES

Resistance between cathode and heater	max. 1,0 M Ω
Impedance between cathode and heater	max. 0,1 M Ω
Grid 1 circuit resistance	max. 1,5 M Ω
Grid 1 circuit impedance	max. 0,5 M Ω

TYPICAL OPERATING CONDITIONS

Cathode drive; voltages specified with respect to grid 1

Anode voltage	12 kV
Grid 4 (focusing electrode) voltage	0 to 300 V*
Grid 2 voltage	700 V
Cathode cut-off voltage	57 to 97 V**

Grid drive; voltages specified with respect to cathode

Anode voltage	12 kV
Grid 4 (focusing electrode) voltage	0 to 300 V*
Grid 2 voltage	700 V
Grid 1 cut-off voltage	65 to 107 V**

RESOLUTION

The resolution is approx. 1300 lines. It is measured at the screen centre:

- with shrinking raster method,
- at light output 68,5 cd/m² (20 foot lambert) and raster dimensions 216 x 162 mm,
- at $V_{g2} = 700$ V and anode voltage = 12kV,
- with phosphor type W (WW),
- with normal tinted face glass, without anti-glare treatment of screen surface.

X-RADIATION CHARACTERISTIC

X-radiation emitted will not exceed 0,5 mR/h throughout the useful life of the tube, when operated within the given ratings.

* Measured at screen centre on spot at anode current = 250 μ A (peak), anode voltage = 12 kV, grid 2 voltage = 700 V.

Dynamic focus (only for optimization): Typical correction for a video field of H x V = 216 mm x 162 mm:
line parabola 200 V,
field parabola 100 V.

** Visual extinction of focused raster.

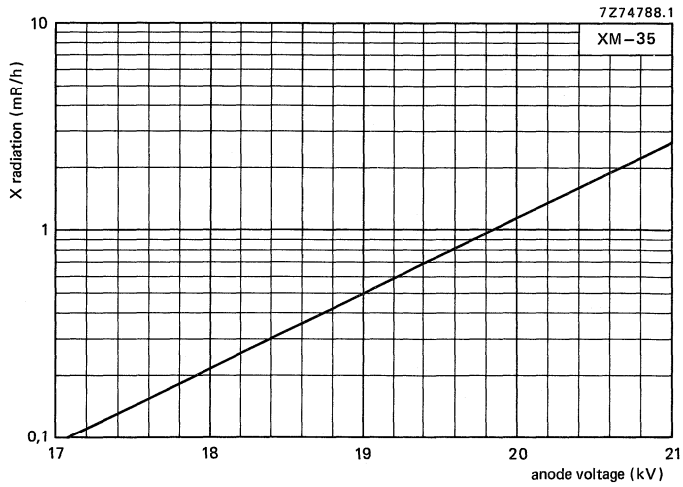

Fig. 1 X-radiation limit curve according to JEDEC94, at a constant anode current of 250 μ A, measured according to TEPAC103A.

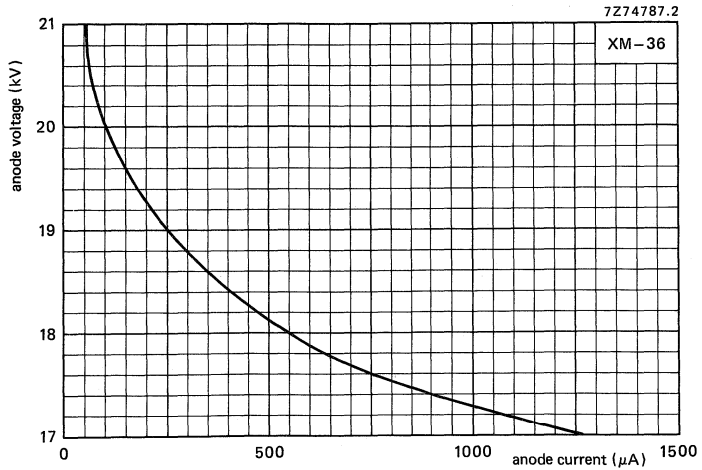

Fig. 2 0,5 mR/h isoexposure-rate limit curve, according to JEDEC94, measured according to TEPAC103A.

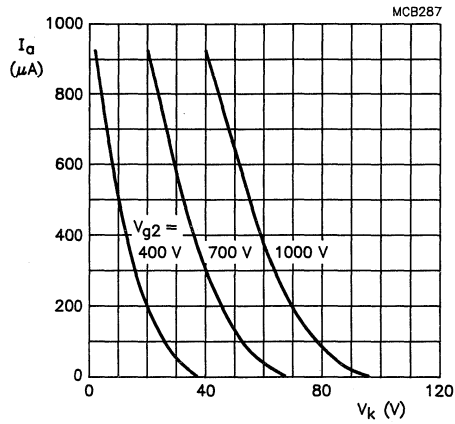

Fig. 3 Anode current as a function of cathode voltage.
Cathode drive; $V_{a,g3,g5} = 12$ kV.

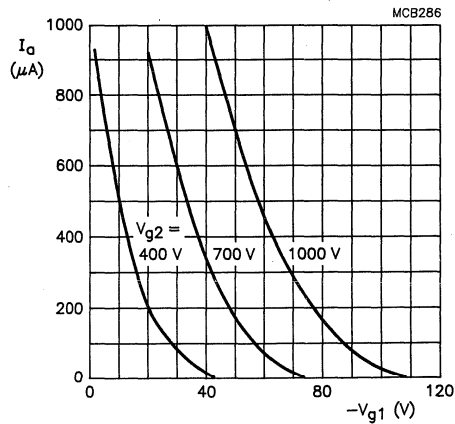

Fig. 4 Anode current as a function of grid 1 voltage.
Grid drive; $V_{a,g3,g5} = 12$ kV.

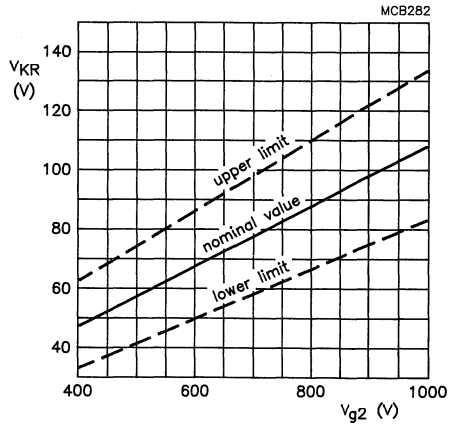

Fig. 5 Limits of cathode cut-off voltage as a function of grid 2 voltage. Cathode drive; $V_{a,g3,g5} = 12$ kV.

$$\frac{\Delta V_{KR}}{\Delta V_{a,g3,g5}} = 0.9 \times 10^{-3}$$

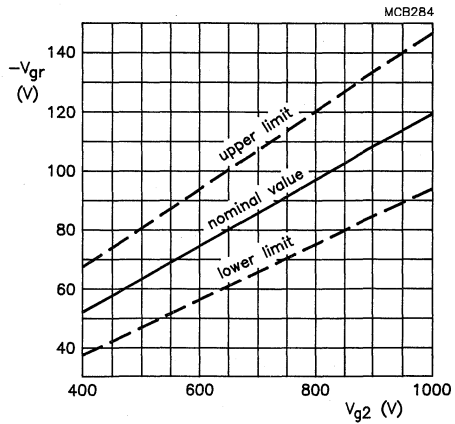
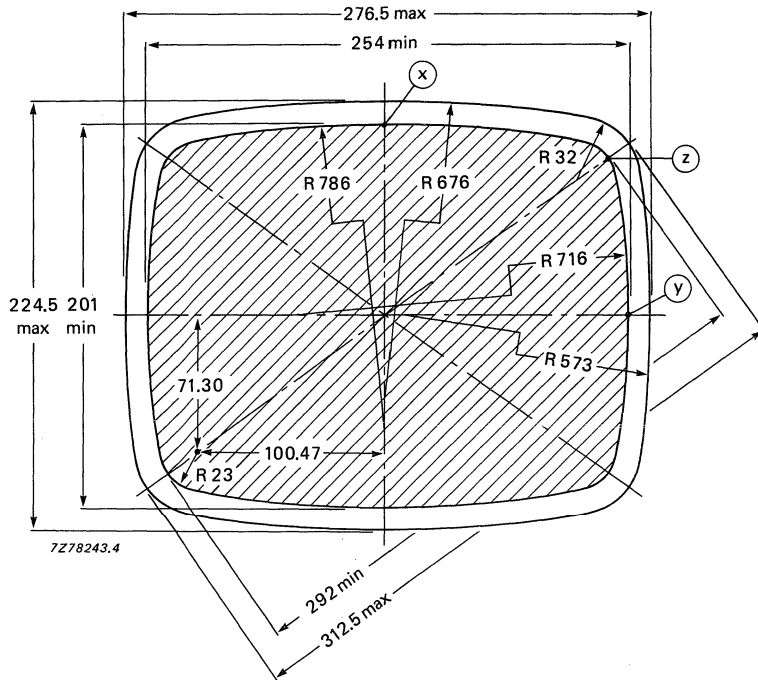
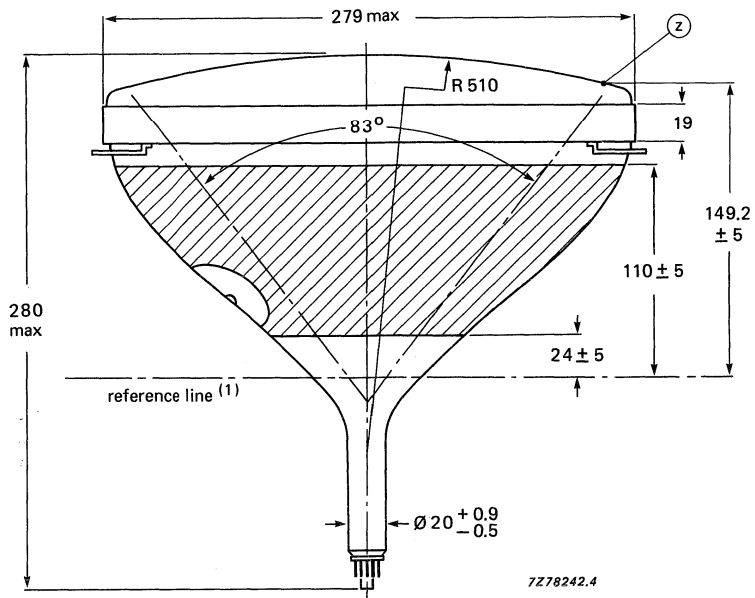

Fig. 6 Limits of grid 1 cut-off voltage as a function of grid 2 voltage. Grid drive; $V_{a,g3,g5} = 12$ kV.

$$\frac{\Delta V_{GR}}{\Delta V_{a,g3,g5}} = 0.9 \times 10^{-3}$$

DIMENSIONAL DATA

Dimensions in mm



(1) The reference line is determined by the plane of the upper edge of reference line gauge D when the gauge is resting on the cone.

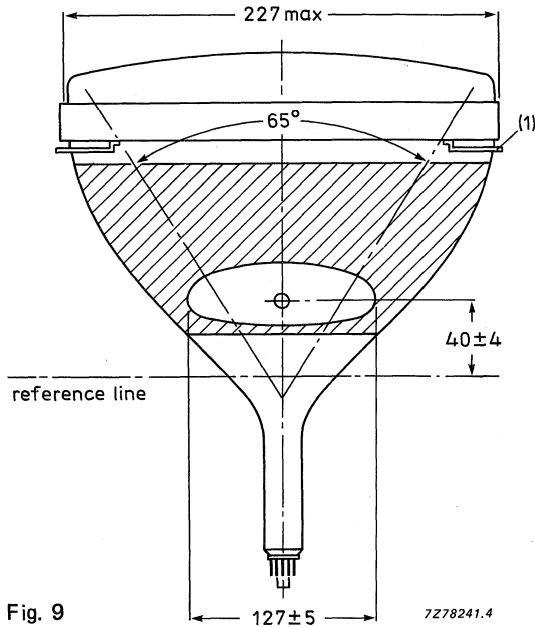

Fig. 9

(1) The displacement of any lug with respect to the plane through the other three lugs is max. 2 mm.

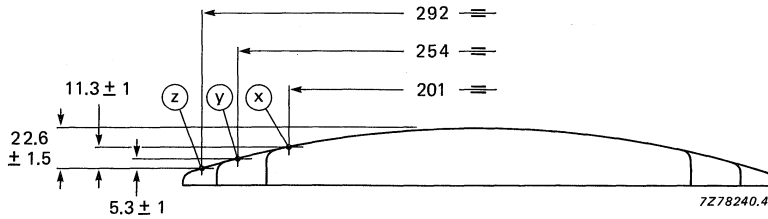

Fig. 10 Screen reference points.

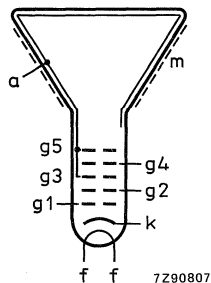

Fig. 11 Electrode configuration.

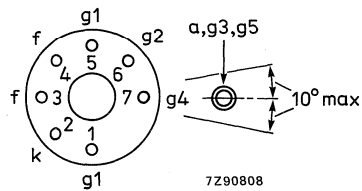

Fig. 12 Pin arrangement.

Front-view and lug dimensions of tube

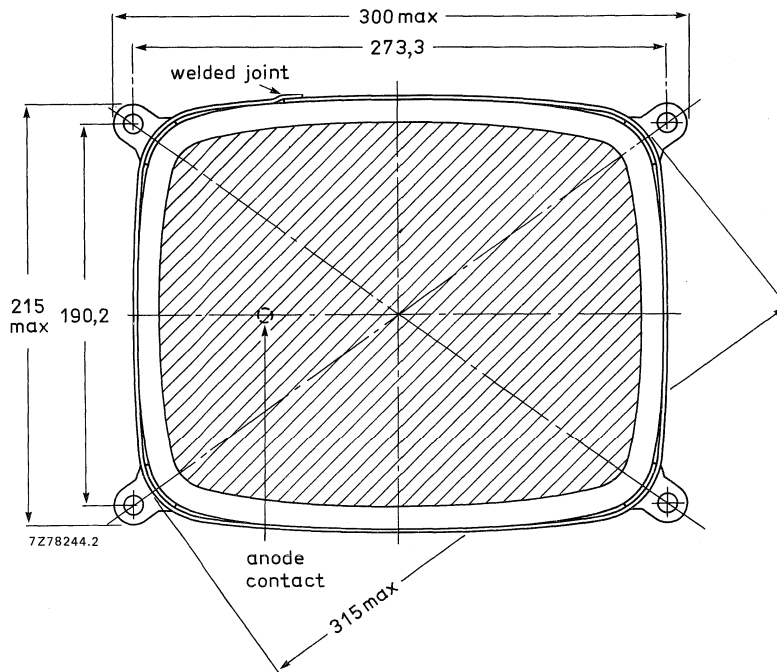

Fig. 13 Tube mounting dimensions; front view.

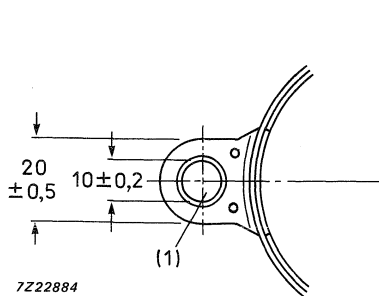

Fig. 14 Lug dimensions.

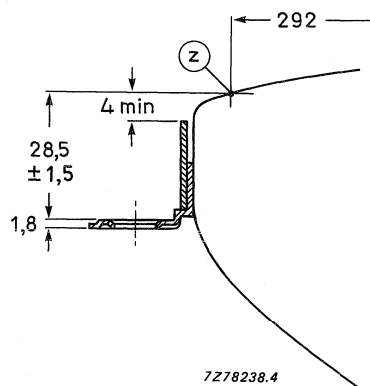

Fig. 15 Lug position.

(1) The position of the mounting screws in the cabinet must be within a circle of 7 mm diameter drawn around the true geometrical positions, i.e. the corners of a rectangle of 273.3 mm x 190.2 mm.

Maximum cone contour

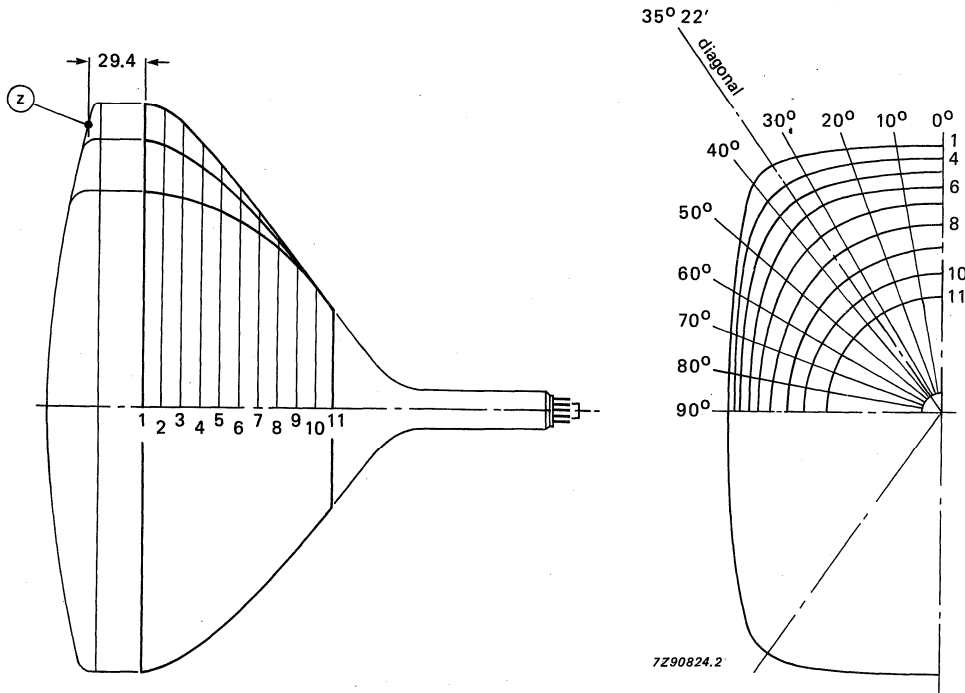

Fig. 16 Cone contour.

Table 1 Cone contour data

sec- tion	nom. distance from section 1	max. distance from centre										
		0°	10°	20°	30°	diag.	40°	50°	60°	70°	80°	90°
1	0	138,3	139,9	145,0	153,9	156,6	154,7	138,9	126,3	118,2	113,7	112,3
2	10	136,5	138,1	143,2	151,5	154,4	152,6	137,5	125,0	116,9	112,4	110,9
3	20	131,8	133,4	138,1	145,1	147,5	146,2	133,8	122,1	114,3	110,0	108,6
4	30	125,2	126,6	130,6	136,0	137,5	136,6	127,9	117,8	110,7	106,6	105,3
5	40	117,0	118,2	121,3	124,8	125,6	125,0	119,6	112,1	106,1	102,5	101,3
6	50	107,9	108,8	111,0	113,1	113,5	113,2	110,2	105,2	100,6	97,6	96,6
7	60	98,1	98,7	100,0	101,1	101,3	101,2	99,8	97,2	94,3	92,0	91,2
8	70	87,7	88,0	88,5	89,0	89,1	89,1	88,8	87,9	86,6	85,5	84,9
9	80	76,6	76,5	76,5	76,6	76,8	76,9	77,1	77,3	77,4	77,3	77,2
10	90	64,6	64,4	64,1	64,1	64,2	64,3	64,8	65,5	66,3	66,9	67,3
11	99	51,1	51,1	51,1	51,1	51,1	51,1	51,1	51,1	51,1	51,1	51,1

HIGH RESOLUTION MONOCHROME MONITOR TUBES

- For Data Graphic Displays
- 90° deflection angle
- 31 cm (12 in) face diagonal; rectangular glass
- 3:4 screen aspect ratio
- 635 mm radius of screen curvature
- 20 mm neck diameter
- Integral implosion protection

QUICK REFERENCE DATA

Deflection angle	90°
Face diagonal	31 cm (12 in)
Overall length	max. 277 mm
Neck diameter	20 mm
Heating	12 V/75 mA
Grid 2 voltage	700 V
Anode voltage	12 kV
Resolution	approx. 1300 lines

APPLICATION

These high resolution tubes are for alpha numeric and graphic display applications, such as computer terminals, small business computers, etc.

AVAILABLE VERSIONS

The following versions are available: M31-362, M31-364 and M31-366.

The tubes can be supplied with different phosphors and anti-reflective treatments, see "High resolution monochrome monitor tubes, General".

Differences between the tubes can be found under 'Dimensional Data'.

ELECTRICAL DATA

Focusing method	electrostatic
Deflection method	magnetic
Deflection angles	
diagonal	approx. 90°
horizontal	approx. 78°
vertical	approx. 61°
Interelectrode capacitances	
cathode to all other electrodes	max. 5 pF
grid 1 to all other electrodes	max. 8 pF
Capacitance of external conductive coating to anode*	max. 1200 pF min. 450 pF
Capacitance of external conductive coating to anode**	max. 1050 pF min. 450 pF
Capacitance of anode to implosion protective hardware**	approx. 150 pF
Heater voltage	12 V
Heater current at 12 V	75 mA

OPTICAL DATA

Phosphor type	see "High resolution monochrome monitor tubes, General"
Light transmission at screen centre	
tube with normal tinted face glass	approx. 46%
tube with dark tinted face glass	approx. 34%

RASTER CENTRING

The field intensity perpendicular to the tube axis should be adjustable from 0 to 800 A/m. For optimum overall sharpness it is recommended to centre the raster electrically via the deflection coils.

* Implosion protection hardware connected to external conductive coating.

** Implosion protection hardware not connected to external conductive coating.

MECHANICAL DATA (See also the figures under Dimensional Data)

Overall length	max. 277 mm
Greatest dimensions of tube	
diagonal	321 mm
width	283 mm
height	222 mm
Minimum useful screen dimensions (projected)	
diagonal	294 mm
horizontal axis	257 mm
vertical axis	195 mm
area	478 cm ²
Implosion protection	T-band
Bulb	EIAJ-JB310AP03 or EIAJ-JB310AP04
Bulb contact designation	IEC 67-III-2, EIA-J1-21
Base designation	EIA E7-91
Basing	7GR
Mass	approx. 2,9 kg

RATINGS (Absolute Maximum System)

Unless otherwise specified voltage values are positive and measured with respect to grid 1.

Anode voltage	max. 15 kV min. 10 kV
Grid 4 (focusing electrode) voltage	-200 to + 1000 V
Grid 2 voltage	max. 1000 V min. 400 V
Anode current	
long-term average value	max. 130 μ A
peak value	max. 300 μ A
Cathode voltage, positive peak value	max. 400 V
Heater voltage	12 V +5/-10%*
Cathode-to-heater voltage	max. 100 V

* For maximum cathode life it is recommended that the heater supply be regulated at 12 V $\begin{matrix} +0\% \\ -5\% \end{matrix}$.

CIRCUIT DESIGN VALUES

Grid 4 current	
positive	max. 25 μ A
negative	max. 25 μ A
Grid 2 current	
positive	max. 5 μ A
negative	max. 5 μ A

MAXIMUM CIRCUIT VALUES

Resistance between cathode and heater	max. 1,0 M Ω
Impedance between cathode and heater	max. 0,1 M Ω
Grid 1 circuit resistance	max. 1,5 M Ω
Grid 1 circuit impedance	max. 0,5 M Ω

TYPICAL OPERATING CONDITIONS

Cathode drive; voltages specified with respect to grid 1

Anode voltage	12 kV
Grid 4 (focusing electrode) voltage	0 to 300 V*
Grid 2 voltage	700 V
Cathode cut-off voltage	57 to 97 V**

Grid drive; voltages specified with respect to cathode

Anode voltage	12 kV
Grid 4 (focusing electrode) voltage	0 to 300 V*
Grid 2 voltage	700 V
Grid 1 cut-off voltage	65 to 107 V**

RESOLUTION

The resolution is approx. 1300 lines. It is measured at the screen centre:

- with shrinking raster method,
- at light output 68,5 cd/m² (20 foot lambert) and raster dimensions 216 x 162 mm,
- at $V_{g2} = 700$ V and anode voltage = 12 kV,
- with phosphor type W (WW),
- with normal tinted face glass, without anti-glare treatment of screen surface.

X-RADIATION CHARACTERISTICS

X-radiation emitted will not exceed 0,5 mR/h throughout the useful life of the tube, when operated within the given ratings.

* Measured at screen centre on spot at anode current = 250 μ A (peak), anode voltage = 12 kV, grid 2 voltage = 700 V.

Dynamic focus (only for optimization): Typical correction for a video field of H x V = 216 mm x 162 mm:
line parabola 200 V,
field parabola 100 V.

** Visual extinction of focused raster.

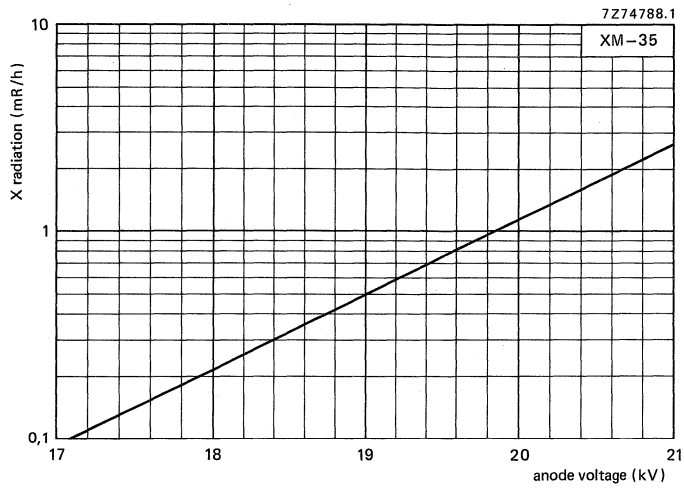

Fig. 1 X-radiation limit curve according to JEDEC 94, at a constant anode current of $250 \mu\text{A}$, measured according to TEPAC103A.

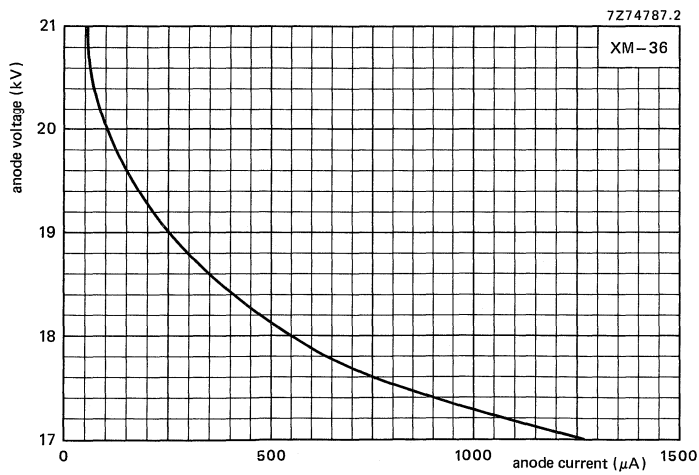

Fig. 2 0,5 mR/h isoexposure-rate limit curve, according to JEDEC94, measured according to TEPAC103A.

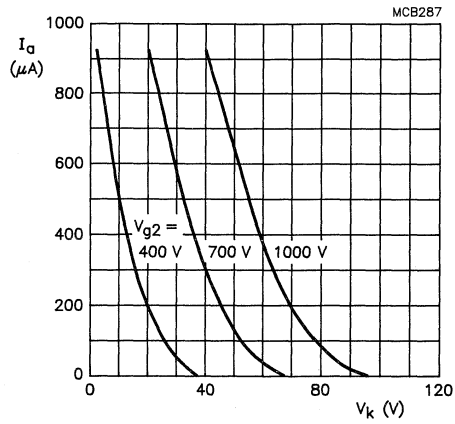

Fig. 3 Anode current as a function of cathode voltage.
Cathode drive; $V_{a,g3,g5} = 12$ kV.

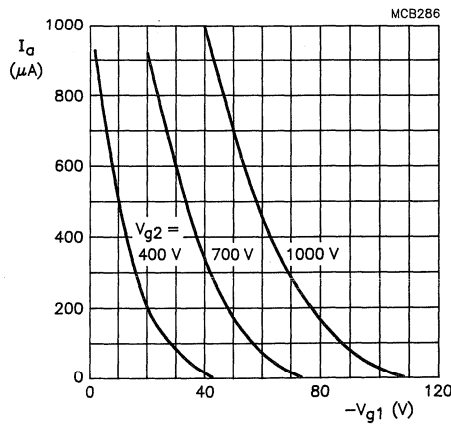

Fig. 4 Anode current as a function of grid 1 voltage.
Grid drive; $V_{a,g3,g5} = 12$ kV.

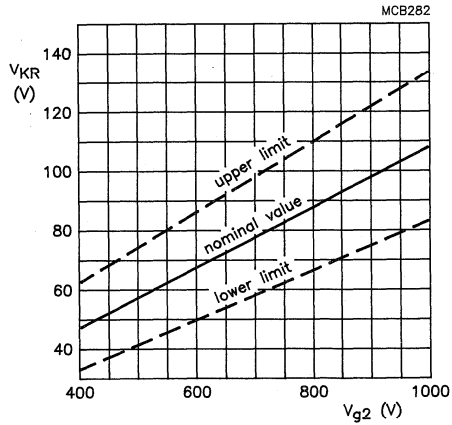

Fig. 5 Limits of cathode cut-off voltage as a function of grid 2 voltage. Cathode drive; $V_{a,g3,g5} = 12$ kV.

$$\frac{\Delta V_{KR}}{\Delta V_{a,g3,g5}} = 0.9 \times 10^{-3}$$

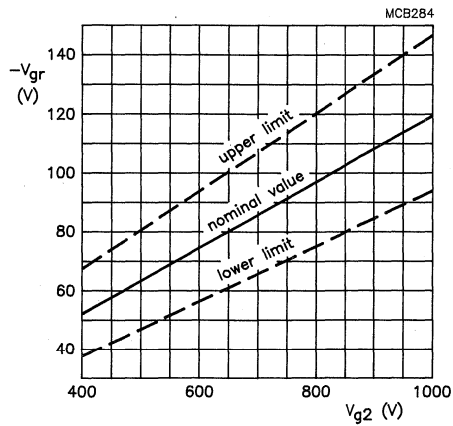

Fig. 6 Limits of grid 1 cut-off voltage as a function of grid 2 voltage. Grid drive; $V_{a,g3,g5} = 12$ kV.

$$\frac{\Delta V_{GR}}{\Delta V_{a,g3,g5}} = 0.9 \times 10^{-3}$$

DIMENSIONAL DATA

Dimensions in mm

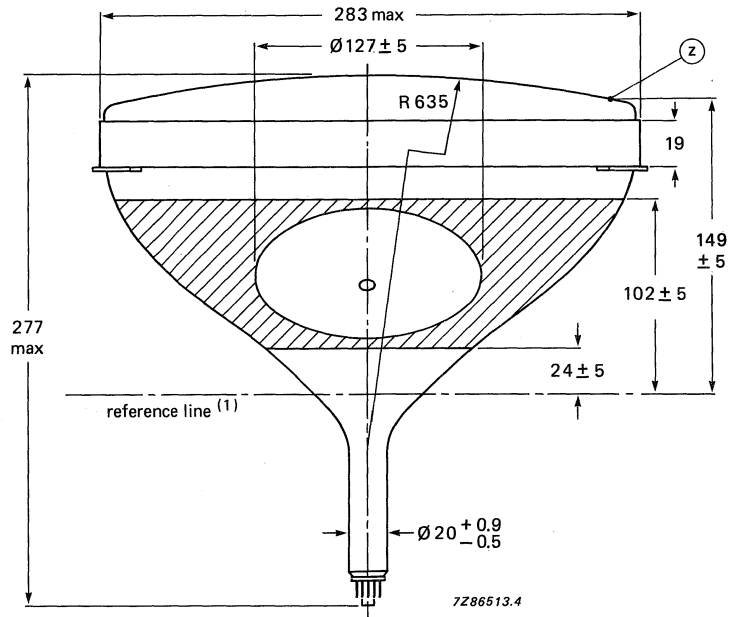

Fig. 7

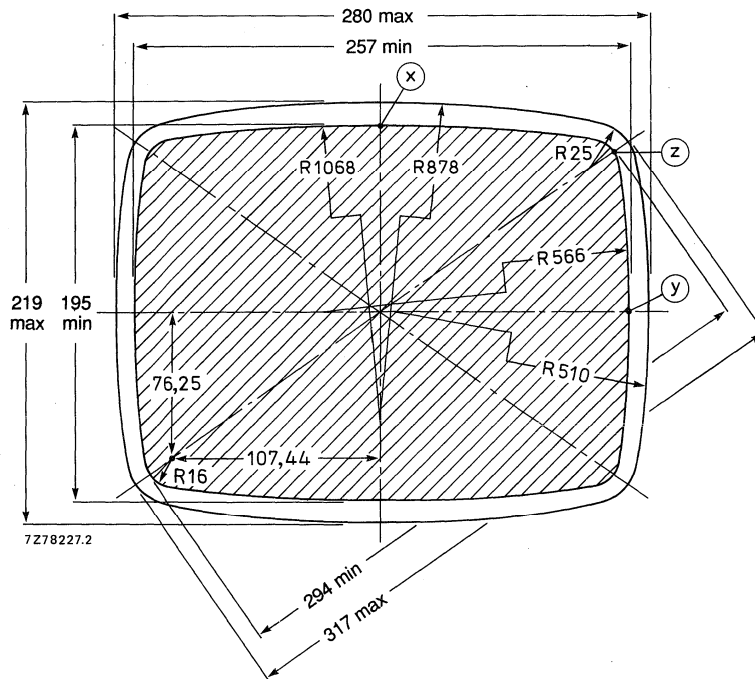

Fig. 8

(1) The reference line is determined by the plane of the upper edge of reference line gauge D when the gauge is resting on the cone.

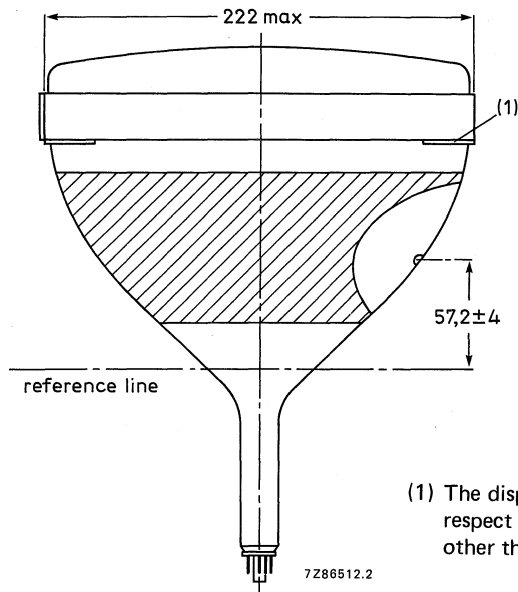

Fig. 9

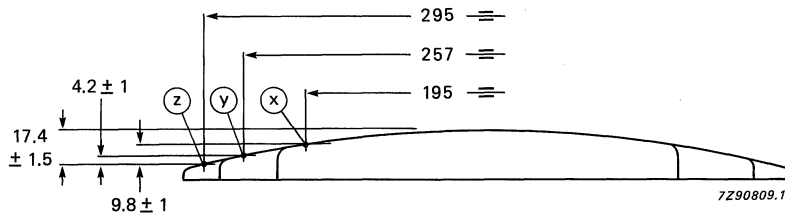

Fig. 10 Screen reference points.

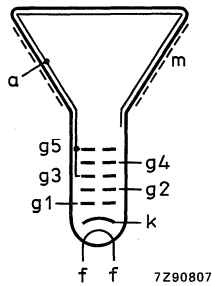

Fig. 11 Electrode configuration.

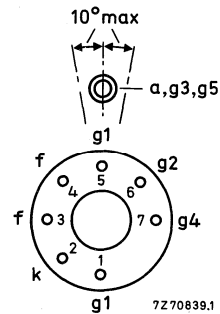

Fig. 12 Pin arrangement.

Front view and lug dimensions of tube M31-362

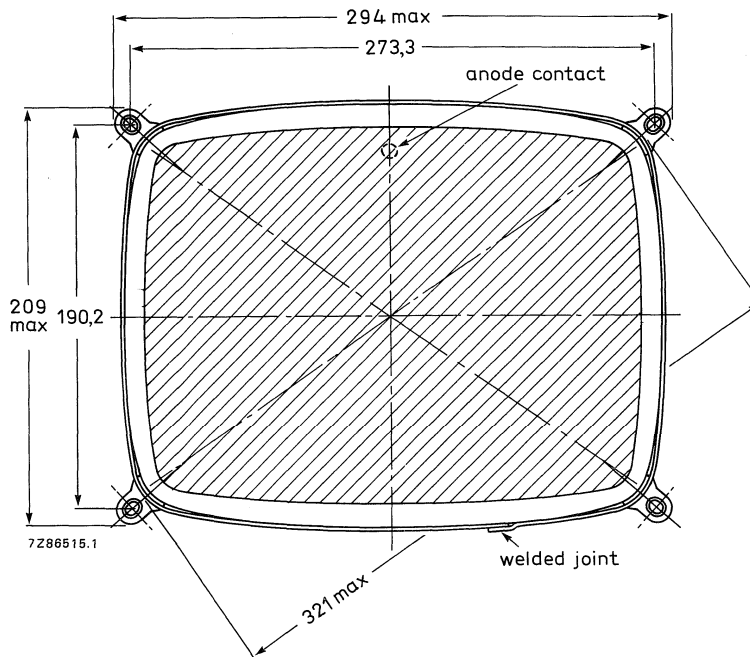

Fig. 13 Tube mounting dimensions; front view.

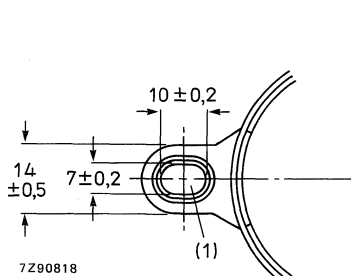

Fig. 14 Lug dimensions.

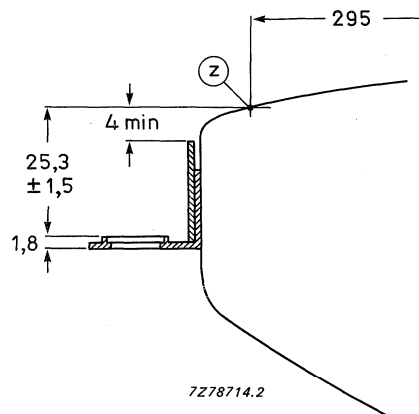

Fig. 15 Lug position.

(1) The mounting screws in the cabinet must be situated inside a circle of 4 mm diameter drawn around the true geometrical positions i.e. at the corners of a rectangle of 273.3 mm x 190.2 mm.

Front view and lug dimensions of tube M31-364

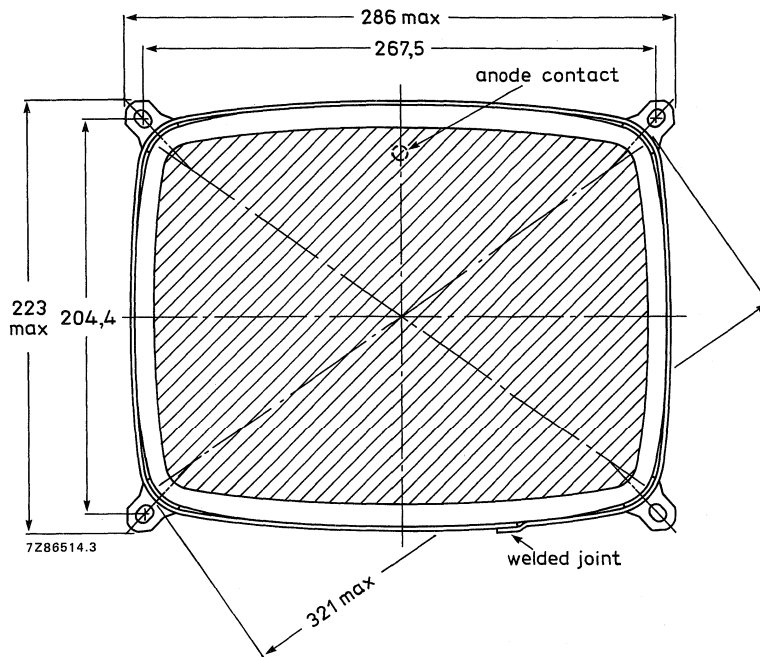

Fig. 16 Tube mounting dimensions; front view.

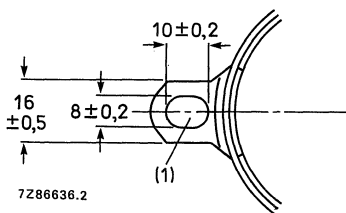

Fig. 17 Lug dimensions.

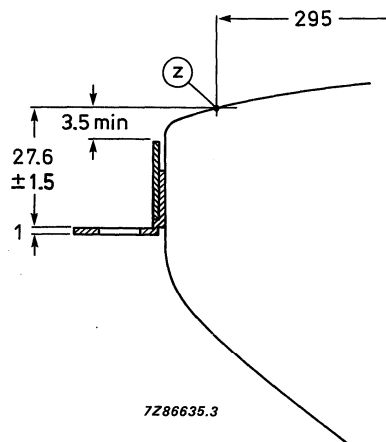

Fig 18 Lug position.

(1) The mounting screws in the cabinet must be situated inside a circle of 5 mm diameter drawn around the true geometrical positions i.e. at the corners of a rectangle of 267.5 mm x 204.4 mm.

Front view and lug dimensions of tube M31-366

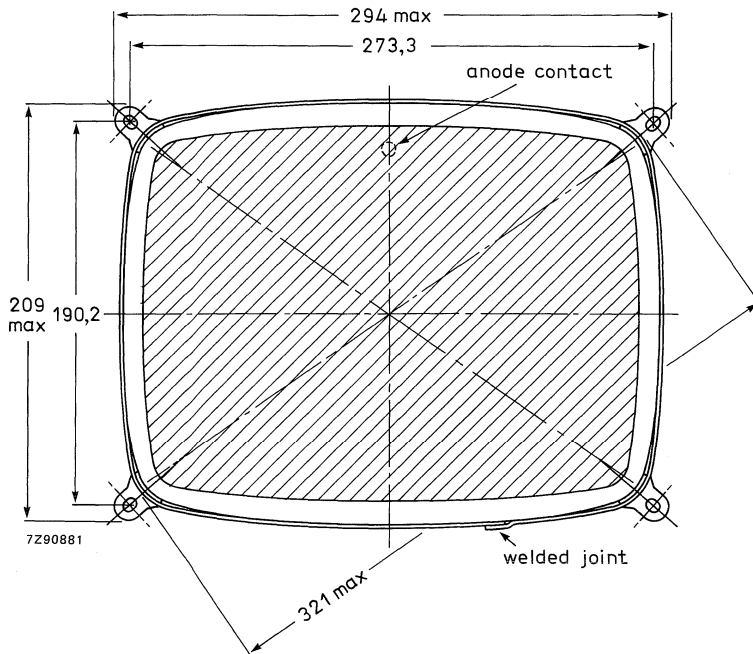

Fig. 19 Tube mounting dimensions; front view.

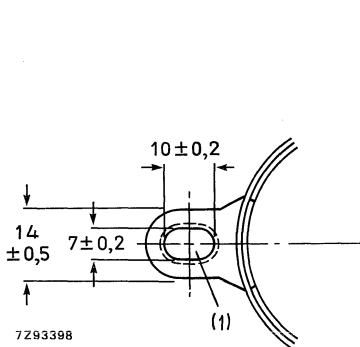

Fig. 20 Lug dimensions.

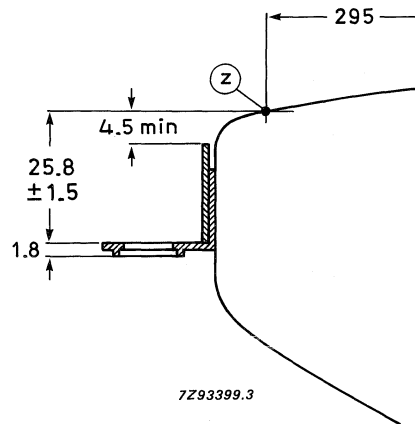

Fig. 21 Lug position.

(1) The mounting screws in the cabinet must be situated inside a circle of 4 mm diameter drawn around the true geometrical positions i.e. at the corners of a rectangle of 273.3 mm x 190.2 mm.

Maximum cone contour

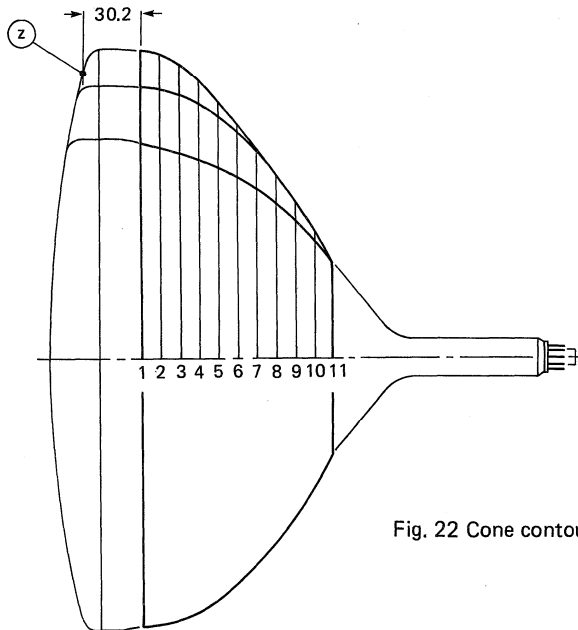
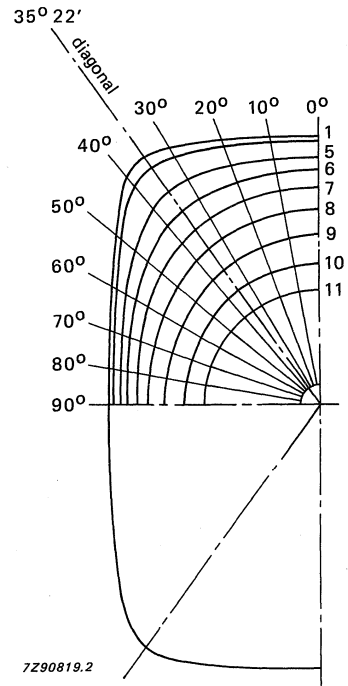

Fig. 22 Cone contour.



7Z90819.2

Table 1 Cone contour data

sec- tion	nom. distance from section 1	max. distance from centre										
		0°	10°	20°	30°	diag.	40°	50°	60°	70°	80°	90°
1	0	140,6	142,4	147,9	156,8	160,4	156,9	139,3	126,1	117,5	112,7	111,2
2	10	139,8	141,6	147,0	155,5	158,5	154,4	136,8	123,7	115,2	110,5	109,0
3	20	137,8	139,4	144,4	151,9	153,6	149,5	133,0	120,4	112,3	107,8	106,4
4	30	133,5	135,0	139,3	144,8	145,1	141,6	127,7	116,3	108,7	104,5	103,1
5	40	126,9	128,1	131,3	134,2	133,6	130,9	120,7	110,9	104,2	100,4	99,1
6	50	117,9	118,8	120,9	122,1	121,1	119,2	112,1	104,5	98,7	95,3	94,2
7	60	107,2	107,9	109,1	109,3	108,5	107,1	102,3	96,8	92,1	89,1	88,1
8	70	95,5	95,9	96,4	96,0	95,2	94,2	91,2	87,5	84,1	81,8	80,9
9	80	82,4	82,5	82,4	81,8	81,2	80,5	78,7	76,6	74,5	73,0	72,4
10	90	67,5	67,5	67,2	66,6	66,3	65,9	65,0	64,1	63,2	62,5	62,2
11	99	50,3	50,3	50,3	50,3	50,3	50,3	50,3	50,3	50,3	50,3	50,3

DEVELOPMENT DATA

This data sheet contains advance information and specifications are subject to change without notice.

M31-380

HIGH RESOLUTION MONOCHROME MONITOR TUBE

- For Data Graphic Displays
- 90° deflection angle
- 31 cm (12 in) face diagonal; rectangular glass
- 3:4 screen aspect ratio
- 635 mm radius of screen curvature
- 20 mm neck diameter
- Integral implosion protection

QUICK REFERENCE DATA

Deflection angle	90°
Face diagonal	31 cm (12 in)
Overall length	max. 277 mm
Neck diameter	20 mm
Heating	12 V/75 mA
Grid 2 voltage	700 V
Anode voltage	12 kV
Resolution	approx. 1300 lines

APPLICATION

This high resolution tube is for alpha numeric and graphic display applications, such as computer terminals, small business computers, etc.

AVAILABLE VERSIONS

The tube can be supplied with different phosphors and anti-reflective treatments, see "High-resolution monochrome monitor tubes, General".

ELECTRICAL DATA

Focusing method	electrostatic
Deflection method	magnetic
Deflection angles	
diagonal	approx. 90°
horizontal	approx. 78°
vertical	approx. 61°
Interelectrode capacitances	
cathode to all other electrodes	max. 5 pF
grid 1 to all other electrodes	max. 8 pF
Capacitance of external conductive coating to anode*	max. 1200 pF min. 450 pF
Capacitance of external conductive coating to anode**	max. 1050 pF min. 450 pF
Capacitance of anode to implosion protective hardware**	approx. 150 pF
Heater voltage	12 V
Heater current at 12 V	75 mA

OPTICAL DATA

Phosphor type	see "High resolution monochrome monitor tubes, General"
Light transmission at screen centre	
tube with normal tinted face glass	approx. 46%
tube with dark tinted face glass	approx. 34%

RASTER CENTRING

The field intensity perpendicular to the tube axis should be adjustable from 0 to 800 A/m. For optimum overall sharpness it is recommended to centre the raster electrically via the deflection coils.

* Implosion protection hardware connected to external conductive coating.

** Implosion protection hardware not connected to external conductive coating.

MECHANICAL DATA (See also the figures under Dimensional Data)

Overall length	max. 277 mm
Greatest dimensions of tube	
diagonal	321 mm
width	283 mm
height	222 mm
Minimum useful screen dimensions (projected)	
diagonal	294 mm
horizontal axis	257 mm
vertical axis	195 mm
area	478 cm ²
Implosion protection	T-band
Bulb	EIAJ-JB310AR03 or EIAJ-JB310AR04
Bulb contact designation	IEC 67-III-2, EIA-J1-21
Base designation	EIA E7-91
Basing	7GR
Mass	approx. 2,9 kg

DEVELOPMENT DATA

RATINGS (Absolute Maximum System)

Unless otherwise specified voltage values are positive and measured with respect to grid 1.

Anode voltage	max. 15 kV min. 10 kV
Grid 4 (focusing electrode) voltage	-200 to + 1000 V
Grid 2 voltage	max. 1000 V min. 400 V
Anode current	
long-term average value	max. 130 μ A
peak value	max. 300 μ A
Cathode voltage, positive peak value	max. 400 V
Heater voltage	12 V +5/-10%
Cathode-to-heater voltage	max. 100 V

* For maximum cathode life it is recommended that the heater supply be regulated at 12 V $\begin{matrix} +0\% \\ -5\% \end{matrix}$.

CIRCUIT DESIGN VALUES

Grid 4 current		
positive	max.	25 μ A
negative	max.	25 μ A
Grid 2 current		
positive	max.	5 μ A
negative	max.	5 μ A

MAXIMUM CIRCUIT VALUES

Resistance between cathode and heater	max.	1,0 M Ω
Impedance between cathode and heater	max.	0,1 M Ω
Grid 1 circuit resistance	max.	1,5 M Ω
Grid 1 circuit impedance	max.	0,5 M Ω

TYPICAL OPERATING CONDITIONS

Cathode drive; voltages specified with respect to grid 1

Anode voltage	12 kV
Grid 4 (focusing electrode) voltage	0 to 300 V*
Grid 2 voltage	700 V
Cathode cut-off voltage	57 to 97 V**

Grid drive; voltages specified with respect to cathode

Anode voltage	12 kV
Grid 4 (focusing electrode) voltage	0 to 300 V**
Grid 2 voltage	700 V
Grid 1 cut-off voltage	65 to 107 V**

RESOLUTION

The resolution is approx. 1300 lines. It is measured at the screen centre:

- with shrinking raster method,
- at light output 68,5 cd/m² (20 foot lambert) and raster dimensions 216 mm x 162 mm,
- at $V_{g2} = 700$ V and anode voltage = 12 kV,
- with phosphor type WW,
- with normal tinted face glass, without anti-glare treatment of screen surface.

X-RADIATION CHARACTERISTIC

X-radiation emitted will not exceed 0,5 mR/h throughout the useful life of the tube, when operated within the given ratings.

* Measured at screen centre on spot at anode current = 250 μ A (peak), anode voltage = 12 kV, grid 2 voltage = 700 V.

Dynamic focus (only for optimization): Typical correction for a video field of H x V = 216 mm x 162 mm:
line parabola 200 V,
field parabola 100 V.

** Visual extinction of focused raster.

DEVELOPMENT DATA

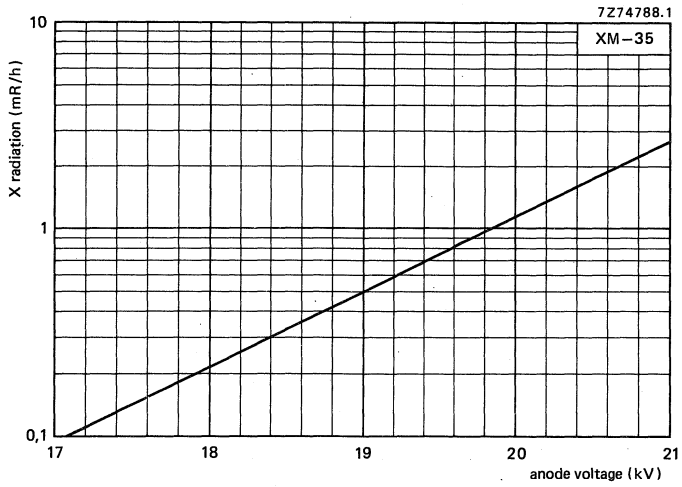

Fig. 1 X-radiation limit curve according to JEDEC 94, at a constant anode current of 250 μ A, measured according to TEPAC103A.

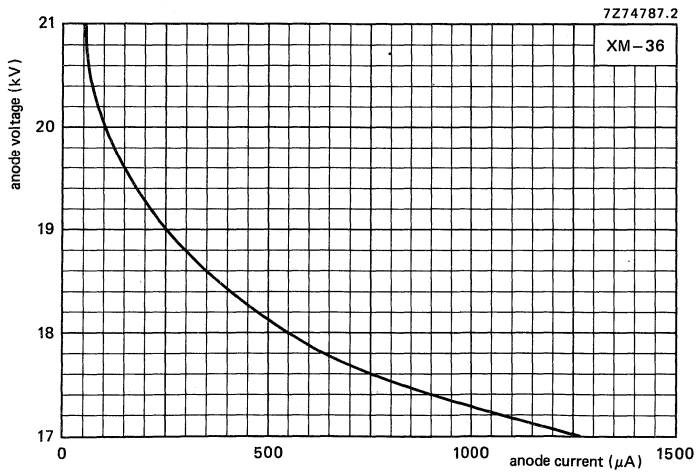

Fig. 2 0,5 mR/h isoexposure-rate limit curve, according to JEDEC94, measured according to TEPAC103A.

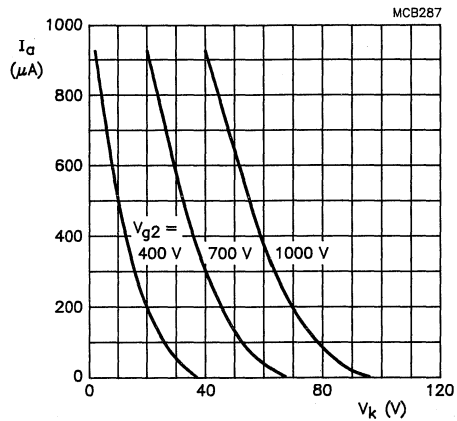

Fig. 3 Anode current as a function of cathode voltage.
Cathode drive; $V_{a,g3,g5} = 12$ kV.

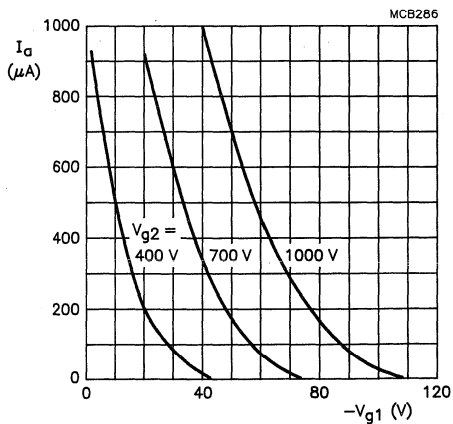

Fig. 4 Anode current as a function of grid 1 voltage.
Grid drive; $V_{a,g3,g5} = 12$ kV.

DEVELOPMENT DATA

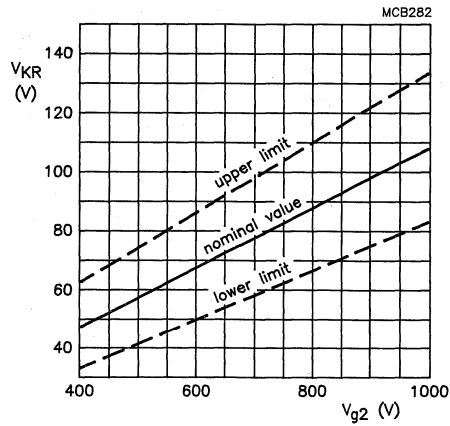

Fig. 5 Limits of cathode cut-off voltage as a function of grid 2 voltage. Cathode drive; $V_{a,g3,g5} = 12$ kV.

$$\frac{\Delta V_{KR}}{\Delta V_{a,g3,g5}} = 0.9 \times 10^{-3}$$

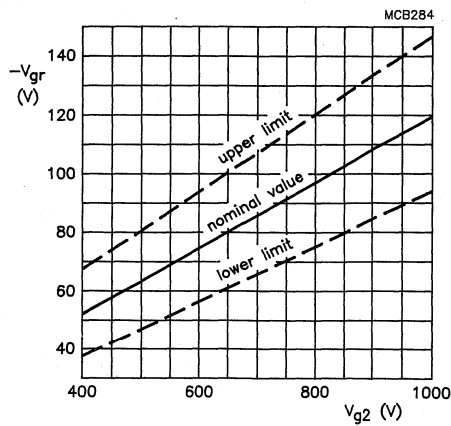

Fig. 6 Limits of grid 1 cut-off voltage as a function of grid 2 voltage. Grid drive; $V_{a,g3,g5} = 12$ kV.

$$\frac{\Delta V_{GR}}{\Delta V_{a,g3,g5}} = 0.9 \times 10^{-3}$$

DEVELOPMENT DATA

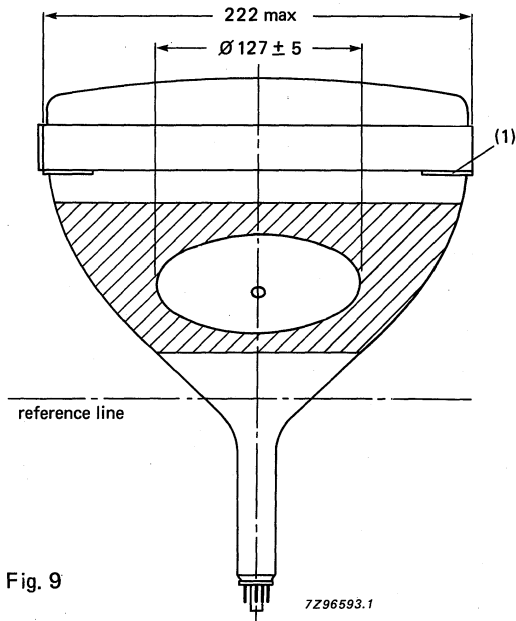

Fig. 9

(1) The displacement of any lug with respect to the plane through the other three lugs is max. 2 mm.

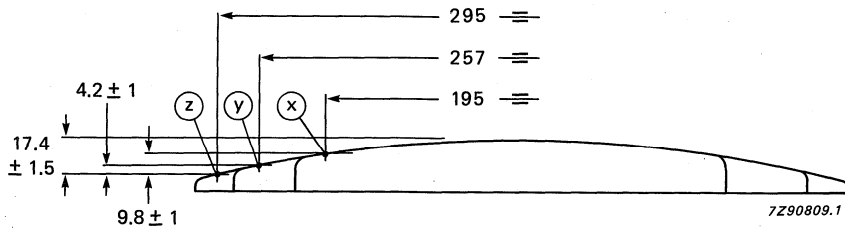

Fig. 10 Screen reference points.

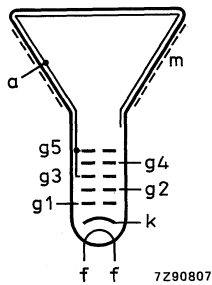

Fig. 11 Electrode configuration.

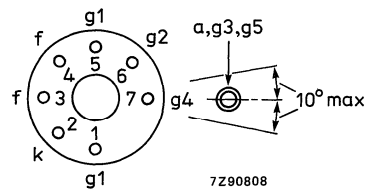

Fig. 12 Pin arrangement.

Front view and lug dimensions

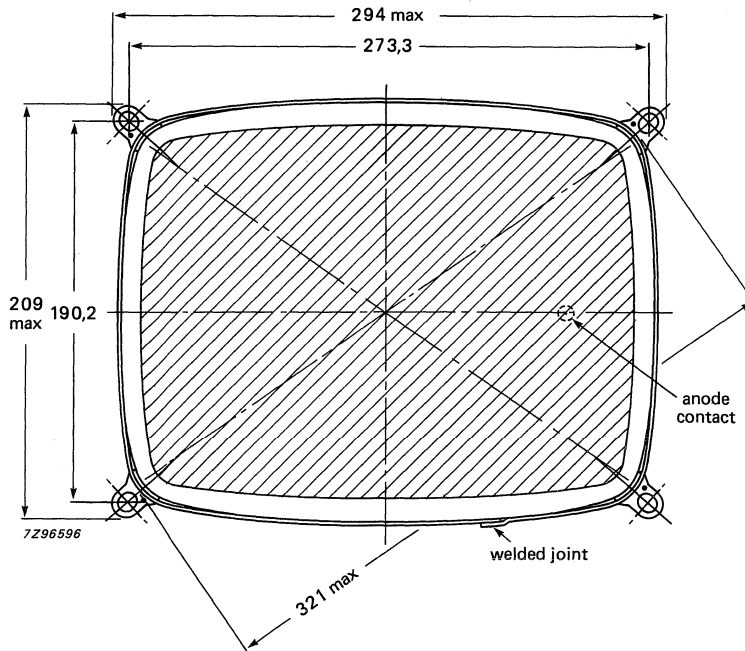

Fig. 13 Tube mounting dimensions; front view.

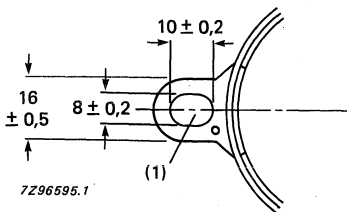

Fig. 14 Lug dimensions.

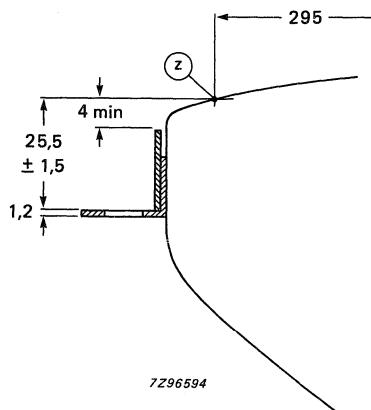

Fig. 15 Lug position.

(1) The mounting screws in the cabinet must be situated inside a circle of 5 mm diameter drawn around the true geometrical positions i.e. at the corners of a rectangle of 273.3 mm x 190.2 mm.

Maximum cone contour

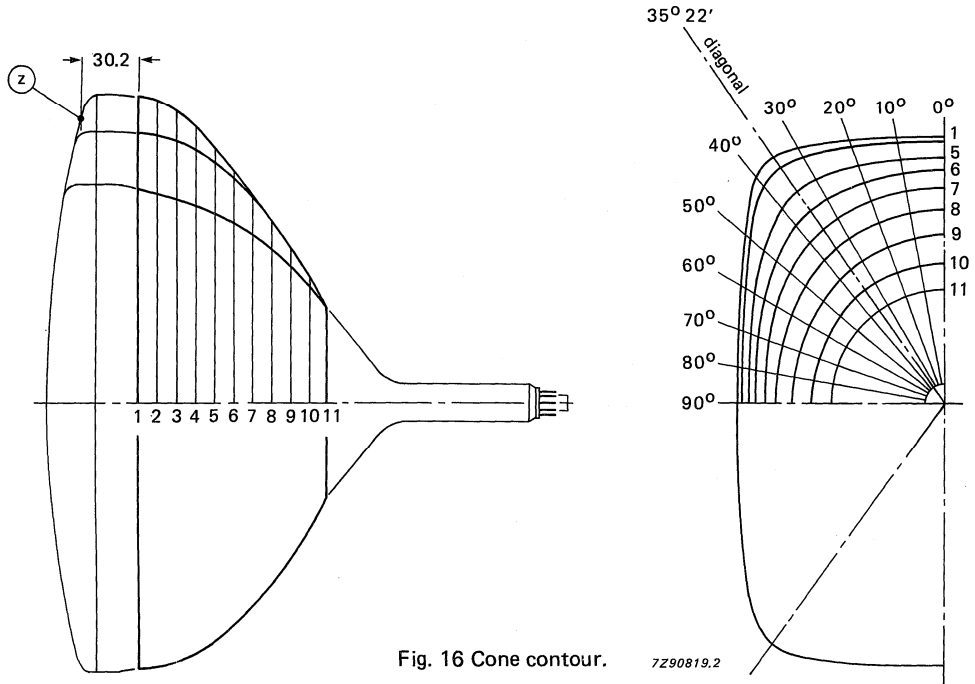

Fig. 16 Cone contour.

7Z90819.2

DEVELOPMENT DATA

Table 1 Cone contour data

sec- tion	nom. distance from section 1	max. distance from centre										
		0°	10°	20°	30°	diag.	40°	50°	60°	70°	80°	90°
1	0	140,6	142,4	147,9	156,8	160,4	156,9	139,3	126,1	117,5	112,7	111,2
2	10	139,8	141,6	147,0	155,5	158,5	154,4	136,8	123,7	115,2	110,5	109,0
3	20	137,8	139,4	144,4	151,9	153,6	149,5	133,0	120,4	112,3	107,8	106,4
4	30	133,5	135,0	139,3	144,8	145,1	141,6	127,7	116,3	108,7	104,5	103,1
5	40	126,9	128,1	131,3	134,2	133,6	130,9	120,7	110,9	104,2	100,4	99,1
6	50	117,9	118,8	120,9	122,1	121,1	119,2	112,1	104,5	98,7	95,3	94,2
7	60	107,2	107,9	109,1	109,3	108,5	107,1	102,3	96,8	92,1	89,1	88,1
8	70	95,5	95,9	96,4	96,0	95,2	94,2	91,2	87,5	84,1	81,8	80,9
9	80	82,4	82,5	82,4	81,8	81,2	80,5	78,7	76,6	74,5	73,0	72,4
10	90	67,5	67,5	67,2	66,6	66,3	65,9	65,0	64,1	63,2	62,5	62,2
11	99	50,3	50,3	50,3	50,3	50,3	50,3	50,3	50,3	50,3	50,3	50,3

DEVELOPMENT DATA

This data sheet contains advance information and specifications are subject to change without notice.

M31-382

HIGH RESOLUTION MONOCHROME MONITOR TUBE

- For Data Graphic Displays
- 90° deflection angle
- 31 cm (12 in) face diagonal; rectangular glass
- 3:4 screen aspect ratio
- 635 mm radius of screen curvature
- 20 mm neck diameter
- Integral implosion protection

QUICK REFERENCE DATA

Deflection angle	90°
Face diagonal	31 cm (12 in)
Overall length	max. 277 mm
Neck diameter	20 mm
Heating	12 V/75 mA
Grid 2 voltage	700 V
Anode voltage	12 kV
Resolution	approx. 1300 lines

APPLICATION

This high resolution tube is for alphanumeric and graphic display applications, such as computer terminals, small business computers, etc.

AVAILABLE VERSIONS

The tube can be supplied with different phosphors and anti-reflective treatments, see "High resolution monochrome monitor tubes, General".

ELECTRICAL DATA

Focusing method	electrostatic
Deflection method	magnetic
Deflection angles	
diagonal	approx. 90°
horizontal	approx. 78°
vertical	approx. 61°
Interelectrode capacitances	
cathode to all other electrodes	max. 5 pF
grid 1 to all other electrodes	max. 8 pF
Capacitance of external conductive coating to anode*	max. 1200 pF min. 450 pF
Capacitance of external conductive coating to anode**	max. 1050 pF min. 450 pF
Capacitance of anode to implosion protective hardware**	approx. 150 pF
Heater voltage	12 V
Heater current at 12 V	75 mA

OPTICAL DATA

Phosphor type	see "High resolution monochrome monitor tubes, General"
Light transmission at screen centre	
tube with normal tinted face glass	approx. 46%
tube with dark tinted face glass	approx. 34%

RASTER CENTRING

The field intensity perpendicular to the tube axis should be adjustable from 0 to 800 A/m. For optimum overall sharpness it is recommended to centre the raster electrically via the deflection coils.

* Implosion protection hardware connected to external conductive coating.

** Implosion protection hardware not connected to external conductive coating.

MECHANICAL DATA (See also the figures under Dimensional Data)

Overall length	max. 277 mm
Greatest dimensions of tube	
diagonal	321 mm
width	283 mm
height	222 mm
Minimum useful screen dimensions (projected)	
diagonal	294 mm
horizontal axis	257 mm
vertical axis	195 mm
area	478 cm ²
Implosion protection	T-band
Bulb	EIAJ-JB310AP03 or EIAJ-JB310AP04
Bulb contact designation	IEC 67-III-2, EIA-J1-21
Base designation	EIA E7-91
Basing	7GR
Mass	approx. 2,9 kg

RATINGS (Absolute Maximum System)

Unless otherwise specified voltage values are positive and measured with respect to grid 1.

Anode voltage	max. 15 kV min. 10 kV
Grid 4 (focusing electrode) voltage	-200 to +1000 V
Grid 2 voltage	max. 1000 V min. 400V
Anode current	
long-term average value	max. 130 μ A
peak value	max. 300 μ A
Cathode voltage, positive peak value	max. 400 V
Heater voltage	12 V +5/-10%
Cathode-to-heater voltage	max. 100 V

DEVELOPMENT DATA

* For maximum cathode life it is recommended that the heater supply be regulated at 12 V $\begin{matrix} +0\% \\ -5\% \end{matrix}$.

CIRCUIT DESIGN VALUES

Grid 4 current	
positive	max. 25 μ A
negative	max. 25 μ A
Grid 2 current	
positive	max. 5 μ A
negative	max. 5 μ A

MAXIMUM CIRCUIT VALUES

Resistance between cathode and heater	max. 1,0 M Ω
Impedance between cathode and heater	max. 0,1 M Ω
Grid 1 circuit resistance	max. 1,5 M Ω
Grid 1 circuit impedance	max. 0,5 M Ω

TYPICAL OPERATING CONDITIONS

Cathode drive; voltages specified with respect to grid 1

Anode voltage	12 kV
Grid 4 (focusing electrode) voltage	0 to 300 V*
Grid 2 voltage	700 V
Cathode cut-off voltage	57 to 97 V**

Grid drive; voltages specified with respect to cathode

Anode voltage	12 kV
Grid 4 (focusing electrode) voltage	0 to 300 V*
Grid 2 voltage	700 V
Grid 1 cut-off voltage	65 to 107 V**

RESOLUTION

The resolution is approx. 1300 lines. It is measured at the screen centre:

- with shrinking raster method,
- at light output 68,5 cd/m² (20 foot lambert) and raster dimensions 216 mm x 162 mm,
- at $V_{g2} = 700$ V and anode voltage = 12 kV,
- with phosphor type WW,
- with normal tinted face glass, without anti-glare treatment of screen surface.

X-RADIATION CHARACTERISTIC

X-radiation emitted will not exceed 0,5 mR/h throughout the useful life of the tube, when operated within the given ratings.

* Measured at screen centre on spot at anode current = 250 μ A (peak), anode voltage = 12 kV, grid 2 voltage = 700 V.

Dynamic focus (only for optimization): Typical correction for a video field of H x V = 216 mm x 162 mm:
line parabola 200 V,
field parabola 100 V.

** Visual extinction of focused raster.

DEVELOPMENT DATA

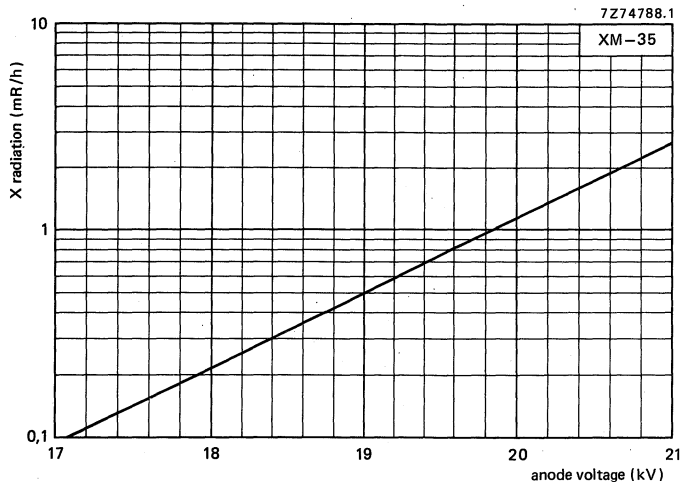

Fig. 1 X-radiation limit curve according to JEDEC 94, at a constant anode current of 250 μ A, measured according to TEPAC103A.

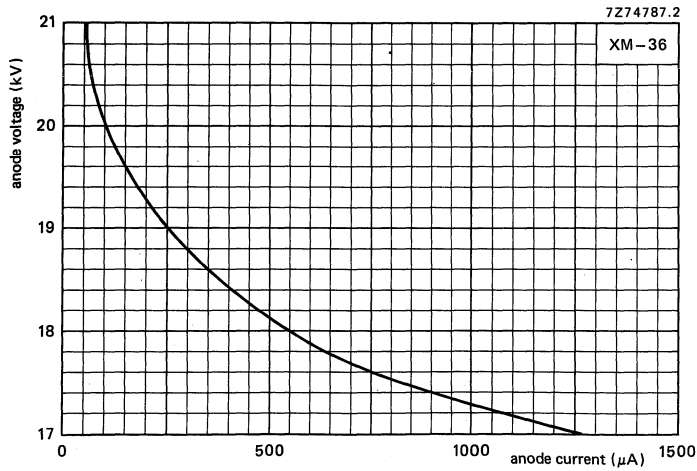

Fig. 2 0,5 mR/h isoexposure-rate limit curve, according to JEDEC94, measured according to TEPAC103A.

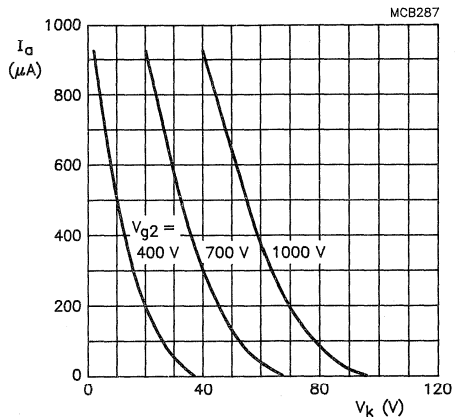

Fig. 3 Anode current as a function of cathode voltage. Cathode drive; $V_{a,g3,g5} = 12$ kV.

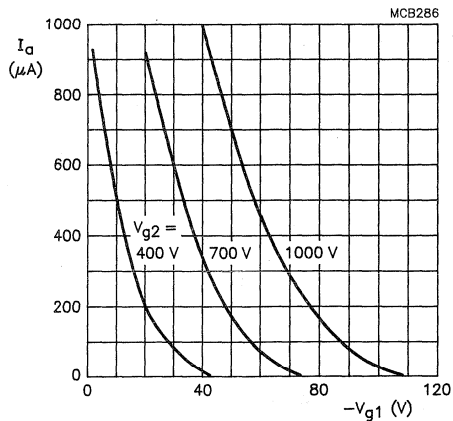

Fig. 4 Anode current as a function of grid 1 voltage. Grid drive; $V_{a,g3,g5} = 12$ kV.

DEVELOPMENT DATA

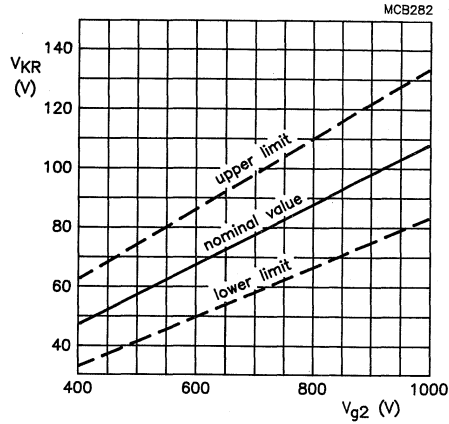

Fig. 5 Limits of cathode cut-off voltage as a function of grid 2 voltage.
Cathode drive; $V_{a,g3,g5} = 12 \text{ kV}$.

$$\frac{\Delta V_{KR}}{\Delta V_{a,g3,g5}} = 0.9 \times 10^{-3}$$

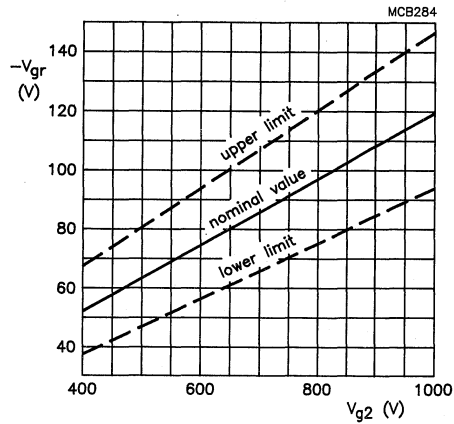

Fig. 6 Limits of grid 1 cut-off voltage as a function of grid 2 voltage.
Grid drive; $V_{a,g3,g5} = 12 \text{ kV}$.

$$\frac{\Delta V_{GR}}{\Delta V_{a,g3,g5}} = 0.9 \times 10^{-3}$$

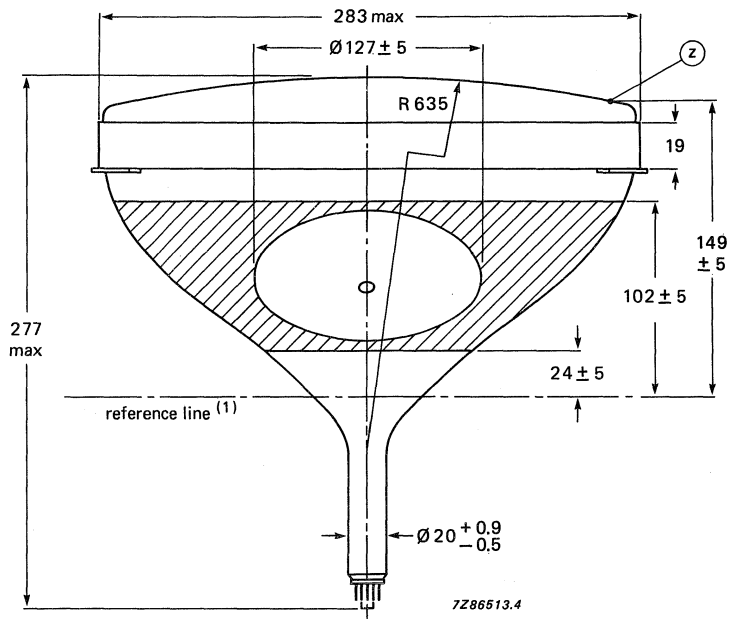

Fig. 7

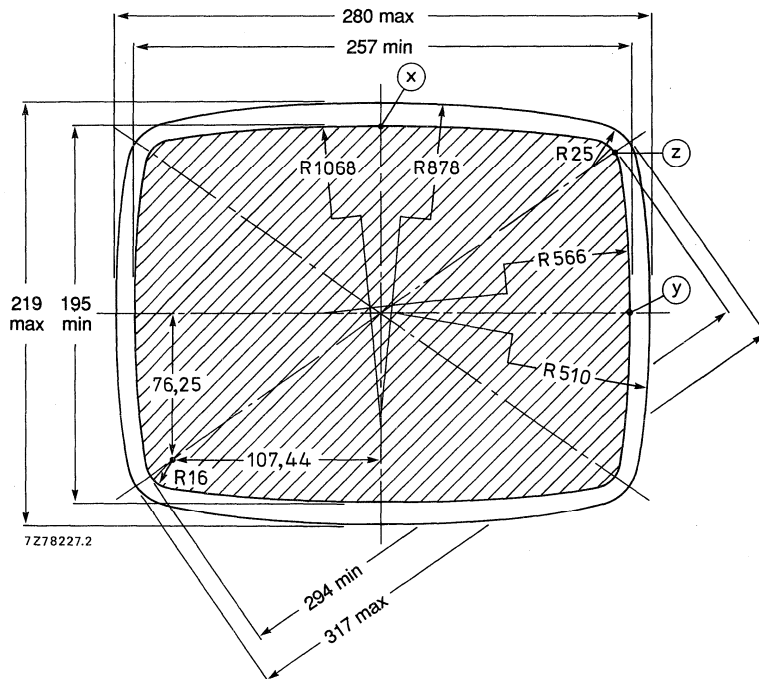

Fig. 8

(1) The reference line is determined by the plane of the upper edge of reference line gauge D when the gauge is resting on the cone.

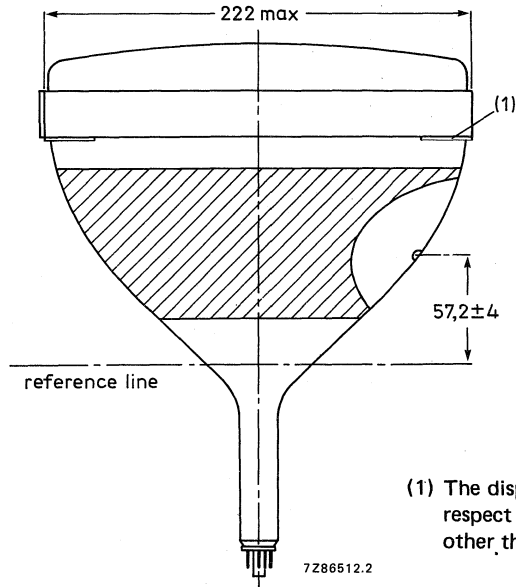

Fig. 9

DEVELOPMENT DATA

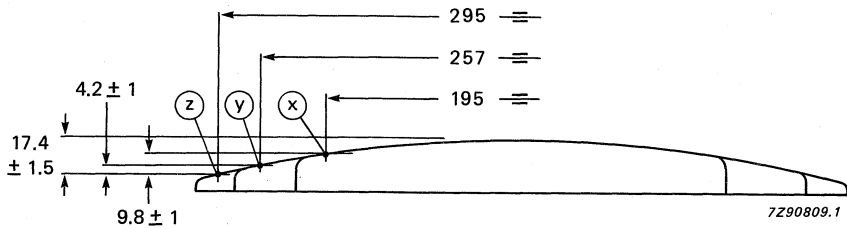

Fig. 10 Screen reference points.

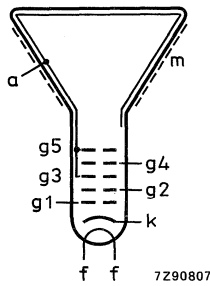

Fig. 11 Electrode configuration.

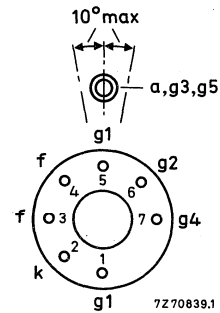

Fig. 12 Pin arrangement.

Front view and lug dimensions of tube

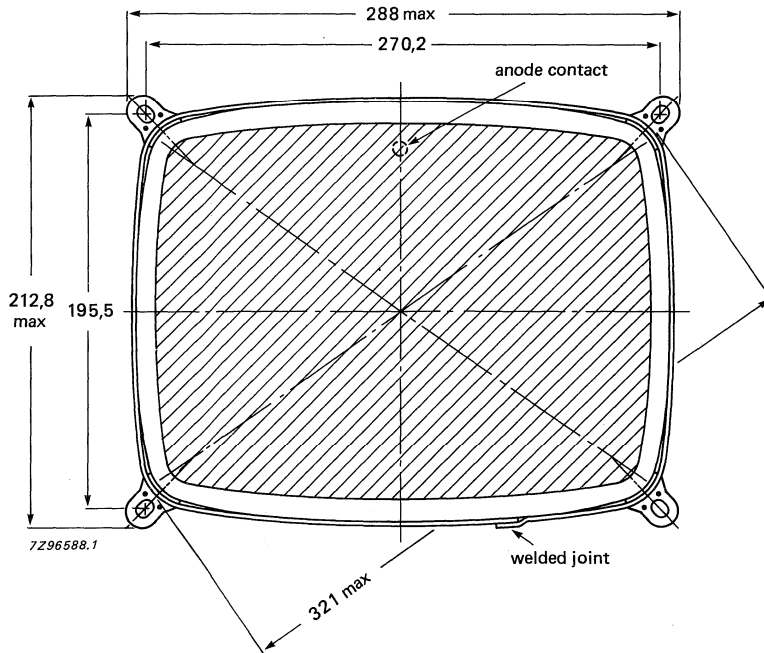

Fig. 13 Tube mounting dimensions; front view.

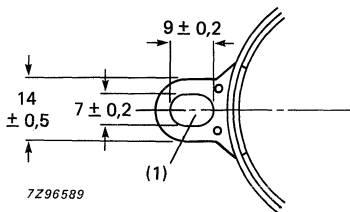

Fig. 14 Lug dimensions.

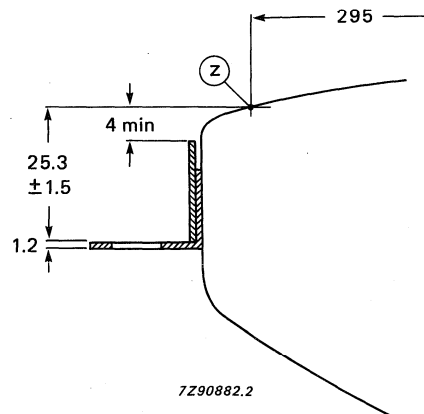

Fig. 15 Lug position.

(1) The mounting screws in the cabinet must be situated inside a circle of 4 mm diameter drawn around the true geometrical positions i.e. at the corners of a rectangle of 270.2 mm x 195.5 mm.

Maximum cone contour

DEVELOPMENT DATA

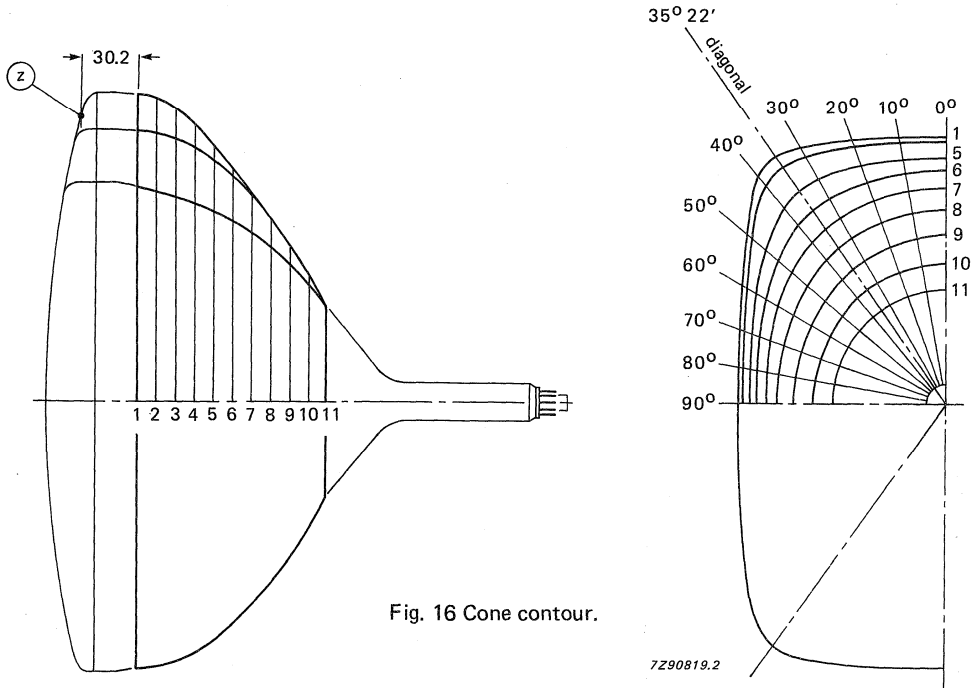

Fig. 16 Cone contour.

Table 1 Cone contour data

sec- tion	nom. distance from section 1	max. distance from centre										
		0°	10°	20°	30°	diag.	40°	50°	60°	70°	80°	90°
1	0	140,6	142,4	147,9	156,8	160,4	156,9	139,3	126,1	117,5	112,7	111,2
2	10	139,8	141,6	147,0	155,5	158,5	154,4	136,8	123,7	115,2	110,5	109,0
3	20	137,8	139,4	144,4	151,9	153,6	149,5	133,0	120,4	112,3	107,8	106,4
4	30	133,5	135,0	139,3	144,8	145,1	141,6	127,7	116,3	108,7	104,5	103,1
5	40	126,9	128,1	131,3	134,2	133,6	130,9	120,7	110,9	104,2	100,4	99,1
6	50	117,9	118,8	120,9	122,1	121,1	119,2	112,1	104,5	98,7	95,3	94,2
7	60	107,2	107,9	109,1	109,3	108,5	107,1	102,3	96,8	92,1	89,1	88,1
8	70	95,5	95,9	96,4	96,0	95,2	94,2	91,2	87,5	84,1	81,8	80,9
9	80	82,4	82,5	82,4	81,8	81,2	80,5	78,7	76,6	74,5	73,0	72,4
10	90	67,5	67,5	67,2	66,6	66,3	65,9	65,0	64,1	63,2	62,5	62,2
11	99	50,3	50,3	50,3	50,3	50,3	50,3	50,3	50,3	50,3	50,3	50,3

HIGH RESOLUTION MONOCHROME MONITOR TUBES

- For Data Graphic Displays
- 90° deflection angle
- 34 cm (14 in) face diagonal; rectangular glass
- 20 mm neck diameter
- Integral implosion protection

QUICK REFERENCE DATA

Deflection angle	90°
Face diagonal	34 cm (14 in)
Overall length	max. 287 mm
Neck diameter	20 mm
Heating	12 V/130 mA
Quick heating cathode	with a typical tube a legible picture will appear within 5 s
Grid 2 voltage	700 V
Anode voltage	14 kV
Resolution	approx. 1300 lines

APPLICATION

This high resolution tube is for alphanumeric and graphic display applications, such as computer terminals, small business computers, etc.

AVAILABLE VERSIONS

The following versions are available: M32EAA and M32EBF.

The tubes can be supplied with different phosphors and anti-reflective treatments, see "High resolution monochrome monitor tubes, General".

Differences between the tubes can be found under 'Dimensional data'.

ELECTRICAL DATA

Focusing method	electrostatic
Deflection method	magnetic
Deflection angles	
diagonal	approx. 90°
horizontal	approx. 82°
vertical	approx. 67°
Interelectrode capacitances	
cathode to all other electrodes	max. 5 pF
grid 1 to all other electrodes	max. 7 pF
Capacitance of external conductive coating to anode*	max. 1400 pF min. 800 pF
Capacitance of external conductive coating to anode**	max. 1050 pF min. 450 pF
Capacitance of anode to implosion protection hardware**	approx. 150 pF
Heater voltage	12 V
Heater current at 12 V	130 mA

OPTICAL DATA

Phosphor type	see "High resolution mono-chrome monitor tubes, General"
Light transmission at screen centre	
tube with normal tinted face glass	approx. 48%
tube with dark tinted face glass	approx. 34%

RASTER CENTRING

The field intensity perpendicular to the tube axis should be adjustable from 0 to 800 A/m. For optimum overall sharpness it is recommended to centre the raster electrically via the deflection coils.

* Implosion protection hardware connected to external conductive coating.

** Implosion protection hardware not connected to external conductive coating.

MECHANICAL DATA (see also the figures under Dimensional Data)

Overall length	max. 287 mm
Greatest dimensions of tube	
diagonal	350 mm
width	298 mm
height	240 mm
Minimum useful screen dimensions (projected)	
diagonal	321 mm
horizontal axis	270 mm
vertical axis	210 mm
area	554 cm ²
Implosion protection	T-band/rimband
Bulb	EIAJ-JB340AB03 or EIAJ-JB340AD04
Bulb contact designation	IEC 67-III-2, EIAJ1-21
Base designation	EIA-E7-91
Basing	7GR
Mass	approx. 3,6 kg

RATINGS (Absolute Maximum System)

Unless otherwise specified voltage values are positive and measured with respect to grid 1.

Anode voltage	max. 16 kV min. 10 kV
Grid 4 (focusing electrode) voltage	-200 to + 1000 V
Grid 2 voltage	max. 1000 V min. 400 V
Anode current	
long-term average value	max. 130 μ A
peak value	max. 300 μ A
Cathode voltage, positive peak value	max. 400 V
Heater voltage	12 V + 5/-10%*
Cathode-to-heater voltage	max. 100 V

* For maximum cathode life it is recommended that the heater supply be regulated at 12 V $\begin{matrix} +0\% \\ -5\% \end{matrix}$.

CIRCUIT DESIGN VALUES

Grid 4 current	
positive	max. 25 μ A
negative	max. 25 μ A
Grid 2 current	
positive	max. 5 μ A
negative	max. 5 μ A

MAXIMUM CIRCUIT VALUES

Resistance between cathode and heater	max. 1 M Ω
Impedance between cathode and heater	max. 0,1 M Ω
Grid 1 circuit resistance	max. 1,5 M Ω
Grid 1 circuit impedance	max. 0,5 M Ω

TYPICAL OPERATING CONDITIONS

Cathode drive; voltages specified with respect to grid 1

Anode voltage	14 kV
Grid 4 (focusing electrode) voltage	0 to 300 V*
Grid 2 voltage	700 V
Cathode cut-off voltage	57 to 97 V**

Grid drive; voltages specified with respect to cathode

Anode voltage	14 kV
Grid 4 (focusing electrode) voltage	0 to 300 V*
Grid 2 voltage	700 V
Grid 1 cut-off voltage	65 to 107 V**

RESOLUTION

The resolution is approx. 1300 lines. It is measured at the screen centre:

- with shrinking raster method,
- at light output 68,5 cd/m² (20 foot lambert) and raster dimensions 237 mm x 178 mm,
- at $V_{g2} = 700$ V and anode voltage = 14 kV,
- with phosphor type WW,
- with normal tinted face glass, without anti-glare treatment of screen surface.

X-RADIATION CHARACTERISTIC

X-radiation emitted will not exceed 0,5 mR/h throughout the useful life of the tube, when operated within the given ratings.

* Measured at screen centre on spot at anode current = 250 μ A (peak), anode voltage = 14 kV, grid 2 voltage = 700 V.

Dynamic focus (only for optimization): Typical correction for a video field of H x V = 237 mm x 178 mm:
line parabola 200 V,
field parabola 100 V.

** Visual extinction of focused raster.

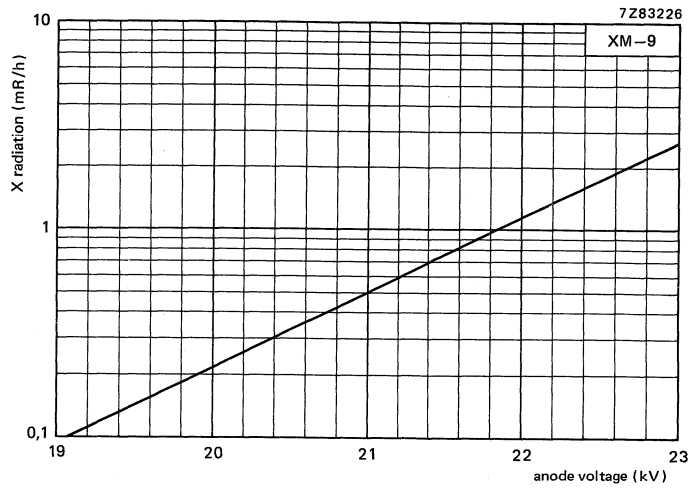

Fig.1 X-radiation limit curve according to JEDEC94, at a constant anode current of 250 μ A, measured according to TEPAC103A.

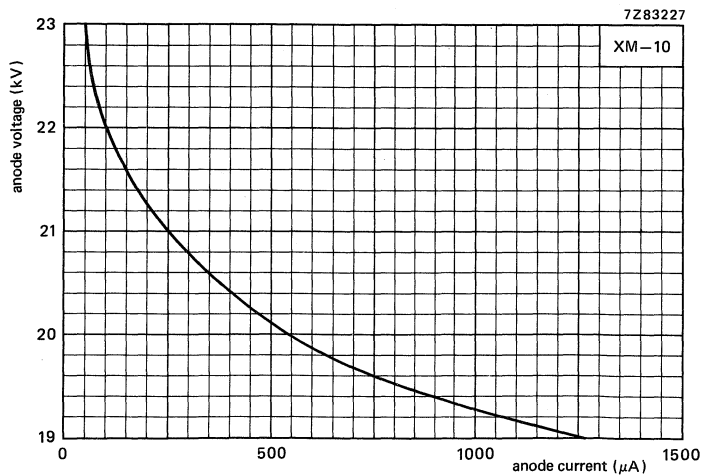

Fig.2 0.5 mR/h isoexposure-rate limit curve, according to JEDEC94, measured according to TEPAC103A.

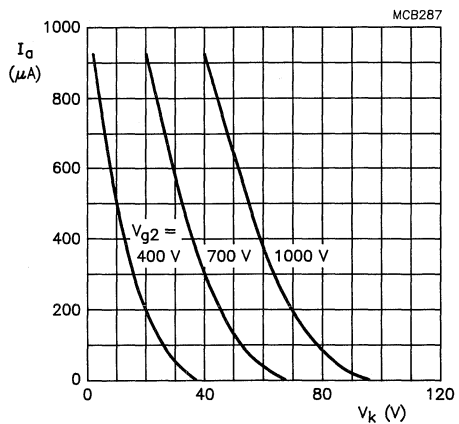

Fig.3 Anode current as a function of cathode voltage.
Cathode drive; $V_{a,g3,g5} = 14$ kV.

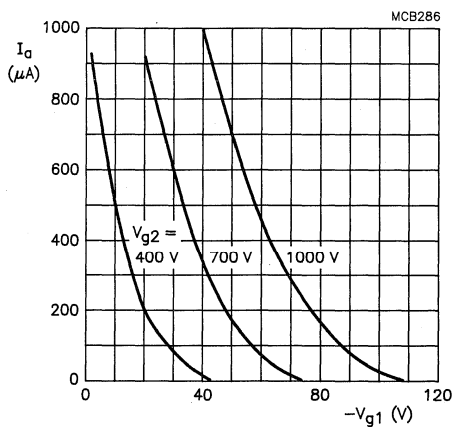

Fig.4 Anode current as a function of grid 1 voltage.
Grid drive; $V_{a,g3,g5} = 14$ kV.

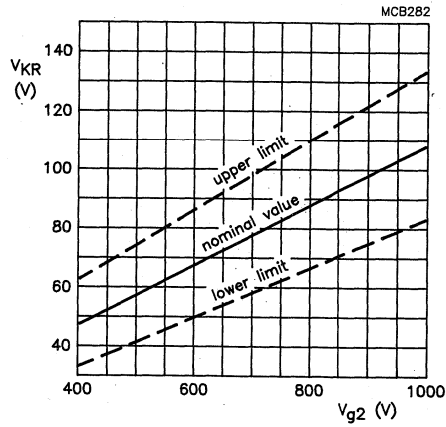

Fig.5 Limits of cathode cut-off voltage as a function of grid 2 voltage.
Cathode drive; $V_{a,g3,g5} = 14$ kV.

$$\frac{\Delta V_{KR}}{\Delta V_{a,g3,g5}} = 0.9 \times 10^{-3}.$$

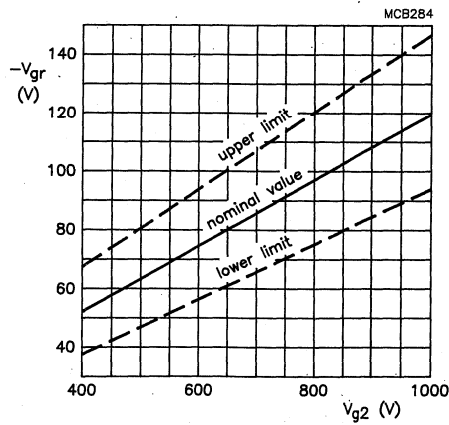
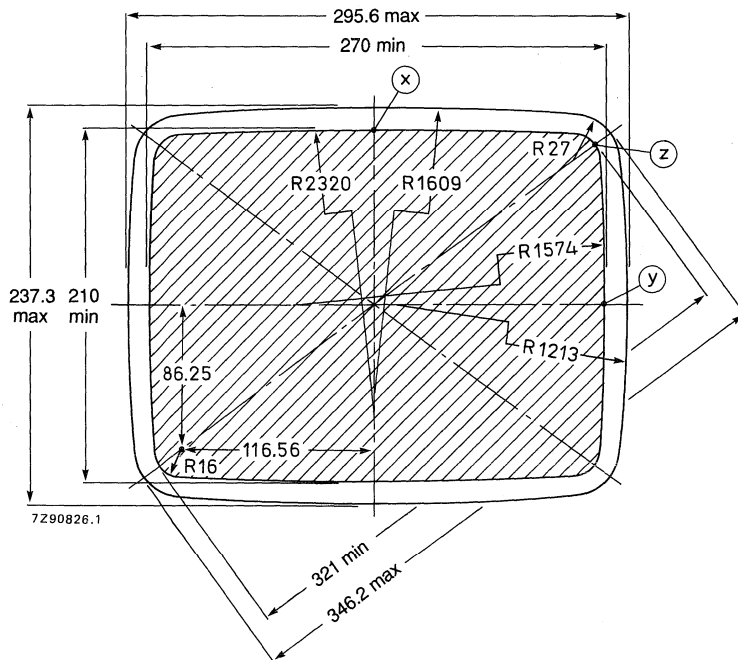
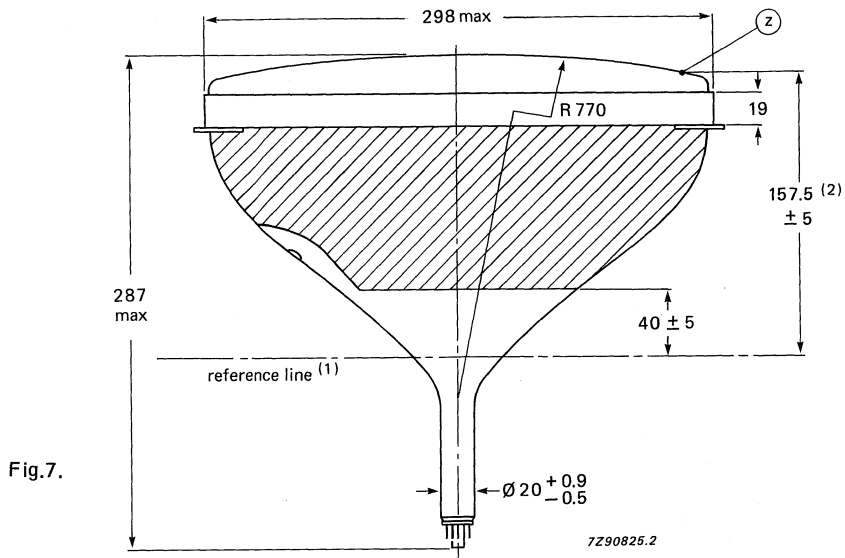

Fig.6 Limits of grid 1 cut-off voltage as a function of grid 2 voltage.
Grid drive; $V_{a,g3,g5} = 14$ kV.

$$\frac{\Delta V_{GR}}{\Delta V_{a,g3,g5}} = 0.9 \times 10^{-3}.$$



- (1) The reference line is determined by the plane of the upper edge of reference line gauge D when the gauge is resting on the cone.
 (2) If NEG type, this value changes to; 159.6 ± 5 .

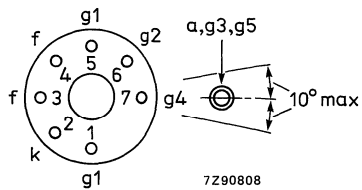
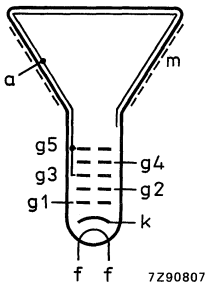
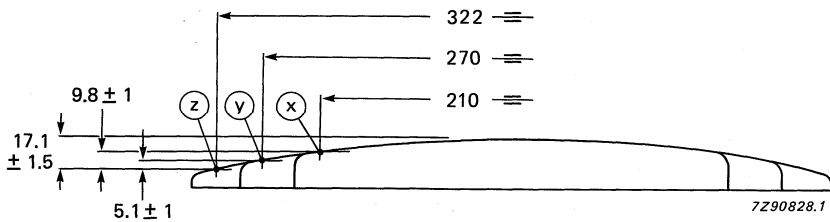
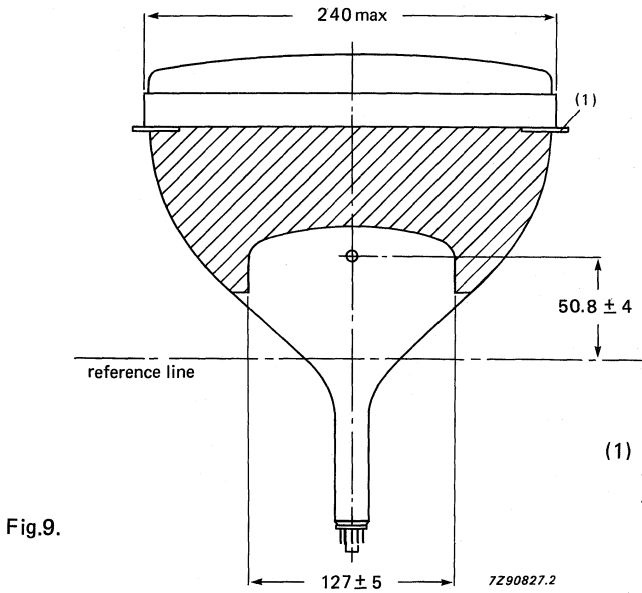

Fig.11 Electrode configuration.

Fig.12 Pin arrangement.

Front view and lug dimensions of tube M32EAA

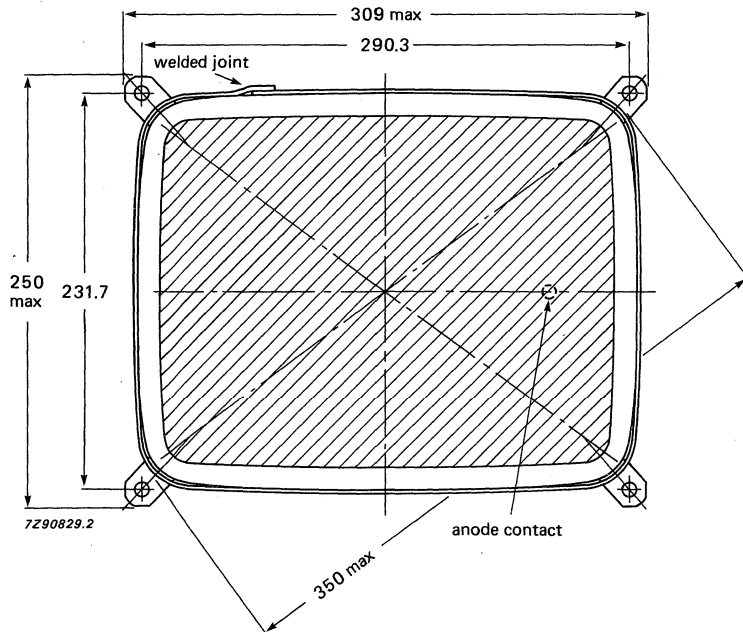

Fig.13 Tube mounting dimensions; front view.

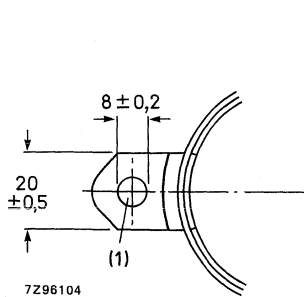

Fig.14 Lug dimensions.

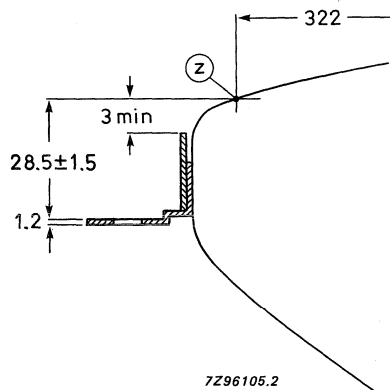

Fig.15 Lug position.

(1) The mounting screws in the cabinet must be situated inside a circle of 4 mm diameter drawn around the true geometrical positions i.e. at the corners of a rectangle of 290.3 mm x 231.7 mm.

Front view and lug dimensions of tube M32EBF *

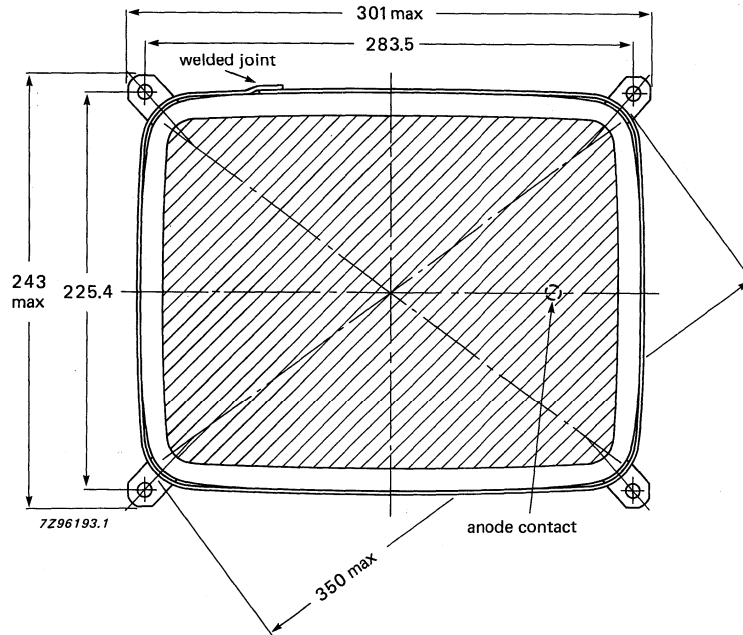

Fig.16 Tube mounting dimensions; front view.

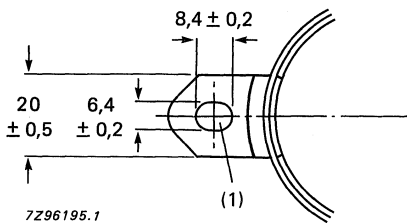

Fig.17 Lug dimensions.

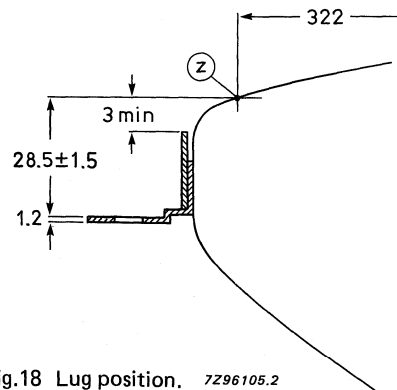

Fig.18 Lug position. 7296105.2

- (1) The mounting screws in the cabinet must be situated inside a circle of 3.4 mm diameter drawn around the true geometrical positions i.e. at the corners of a rectangle of 283.5 mm x 225.4 mm.

* This tube is still under development; data are provisional.

Maximum cone contour

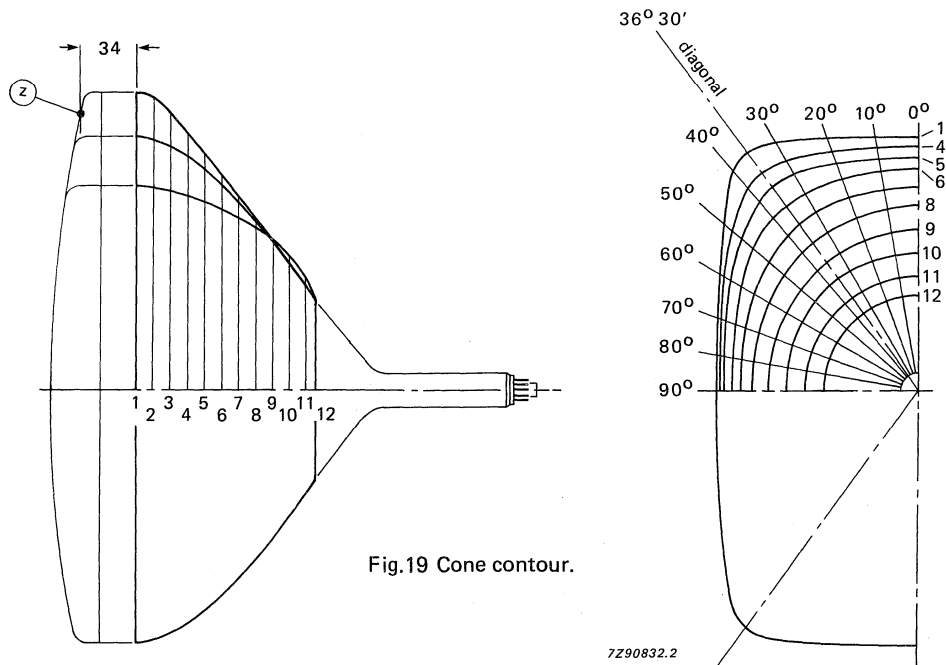

Fig.19 Cone contour.

7290832.2

Table 1 Cone contour data

sec- tion	nom. distance from section 1	max. distance from centre										
		0°	10°	20°	30°	diag.	40°	50°	60°	70°	80°	90°
1	0	148,0	150,1	156,5	167,9	173,6	172,0	152,3	136,3	126,5	121,1	119,4
2	10	146,1	148,2	154,6	165,4	171,0	169,6	150,9	135,2	125,4	120,1	118,4
3	20	142,4	144,3	150,1	158,4	161,6	160,4	146,3	132,0	122,8	117,7	116,1
4	30	136,7	138,4	143,1	148,8	150,2	149,2	139,4	127,6	119,2	114,5	113,0
5	40	128,9	130,3	133,9	137,6	138,3	137,6	131,2	122,2	115,0	110,7	109,3
6	50	119,5	120,6	123,2	125,7	126,2	125,8	122,0	115,8	110,0	106,3	105,1
7	60	109,2	110,1	111,8	113,5	113,9	113,8	111,9	108,1	104,1	101,1	100,1
8	70	98,7	99,2	100,2	101,2	101,5	101,6	100,9	99,1	96,8	94,9	94,1
9	80	87,6	87,7	88,1	88,6	88,9	89,0	89,0	88,6	87,8	86,9	86,4
10	90	75,5	75,4	75,4	75,6	75,7	75,8	76,1	76,3	76,3	76,2	76,1
11	100	62,0	62,0	61,8	61,8	61,8	61,9	62,0	62,2	62,4	62,5	62,5
12	105,7	51,5	51,5	51,5	51,5	51,5	51,5	51,5	51,5	51,5	51,5	51,5

HIGH RESOLUTION MONOCHROME MONITOR TUBES

- For Data Graphic Displays
- 90° deflection angle
- 34 cm (14 in) face diagonal; rectangular glass
- 20 mm neck diameter
- Integral implosion protection

QUICK REFERENCE DATA

Deflection angle	90°
Face diagonal	34 cm (14 in)
Overall length	max. 287 mm
Neck diameter	20 mm
Heating	12 V/75 mA
Grid 2 voltage	700 V
Anode voltage	14 kV
Resolution	approx. 1300 lines

APPLICATION

These high resolution tubes are for alphanumeric and graphic display applications, such as computer terminals, small business computers, etc.

AVAILABLE VERSIONS

The following versions are available: M32EAB, M32EAK and M32ECD.

The tubes can be supplied with different phosphors and anti-reflective treatments, see "High resolution monochrome monitor tubes, General".

Differences between the tubes can be found under 'Dimensional Data'.

ELECTRICAL DATA

Focusing method	electrostatic
Deflection method	magnetic
Deflection angles	
diagonal	approx. 90°
horizontal	approx. 82°
vertical	approx. 67°
Interelectrode capacitances	
cathode to all other electrodes	max. 5 pF
grid 1 to all other electrodes	max. 8 pF
Capacitance of external conductive coating to anode*	max. 1400 pF min. 800 pF
Capacitance of external conductive coating to anode**	max. 1050 pF min. 450 pF
Capacitance of anode to implosion protection hardware**	approx. 150 pF
Heater voltage	12 V
Heater current at 12 V	75 mA

OPTICAL DATA

Phosphor type	see "High resolution mono-chrome monitor tubes, General"
Light transmission at screen centre	
tube with normal tinted face glass	approx. 48%
tube with dark tinted face glass	approx. 34%

RASTER CENTRING

The field intensity perpendicular to the tube axis should be adjustable from 0 to 800 A/m. For optimum overall sharpness it is recommended to centre the raster electrically via the deflection coils.

* Implosion protection hardware connected to external conductive coating.

** Implosion protection hardware not connected to external conductive coating.

MECHANICAL DATA (see also the figures under Dimensional Data)

Overall length	max. 287 mm
Greatest dimensions of tube	
diagonal	350 mm
width	298 mm
height	240 mm
Minimum useful screen dimensions (projected)	
diagonal	321 mm
horizontal axis	270 mm
vertical axis	210 mm
area	554 cm ²
Implosion protection	T-band/rimband
Bulb	EIAJ-JB340AB03 or EIAJ-JB340AD04
Bulb contact designation	IEC 67-III-2, EIAJ1-21
Base designation	EIA-E7-91
Basing	7GR
Mass	approx. 3.6 kg

RATINGS (Absolute Maximum System)

Unless otherwise specified voltage values are positive and measured with respect to grid 1.

Anode voltage	max. 16 kV min. 10 kV
Grid 4 (focusing electrode) voltage	-200 to + 1000 V
Grid 2 voltage	max. 1000 V min. 400 V
Anode current	
long-term average value	max. 130 μ A
peak value	max. 300 μ A
Cathode voltage, positive peak value	max. 400 V
Heater voltage	12 V + 5/-10%
Cathode-to-heater voltage	max. 100 V

* For maximum cathode life it is recommended that the heater supply be regulated at 12 V $\begin{matrix} +0\% \\ -5\% \end{matrix}$.

CIRCUIT DESIGN VALUES

Grid 4 current		
positive	max.	25 μ A
negative	max.	25 μ A
Grid 2 current		
positive	max.	5 μ A
negative	max.	5 μ A

MAXIMUM CIRCUIT VALUES

Resistance between cathode and heater	max.	1 M Ω
Impedance between cathode and heater	max.	0.1 M Ω
Grid 1 circuit resistance	max.	1.5 M Ω
Grid 1 circuit impedance	max.	0.5 M Ω

TYPICAL OPERATING CONDITIONS

Cathode drive; voltages specified with respect to grid 1

Anode voltage	14 kV
Grid 4 (focusing electrode) voltage	0 to 300 V*
Grid 2 voltage	700 V
Cathode cut-off voltage	57 to 97 V**

Grid drive; voltages specified with respect to cathode

Anode voltage	14 kV
Grid 4 (focusing electrode) voltage	0 to 300 V*
Grid 2 voltage	700 V
Grid 1 cut-off voltage	65 to 105 V**

RESOLUTION

The resolution is approx. 1300 lines. It is measured at the screen centre:

- with shrinking raster method,
- at light output 68,5 cd/m² (20 foot lambert) and raster dimensions 237 mm x 178 mm,
- at $V_{g2} = 700$ V and anode voltage = 14 kV,
- with phosphor type WW,
- with normal tinted face glass, without anti-glare treatment of screen surface.

X-RADIATION CHARACTERISTIC

X-radiation emitted will not exceed 0.5 mR/h throughout the useful life of the tube, when operated within the given ratings.

* Measured at screen centre on spot at anode current = 250 μ A (peak), anode voltage = 14 kV, grid 2 voltage = 700 V.

Dynamic focus (only for optimization): Typical correction for a video field of H x V = 237 mm x 178 mm:
line parabola 200 V,
field parabola 100 V.

** Visual extinction of focused raster.

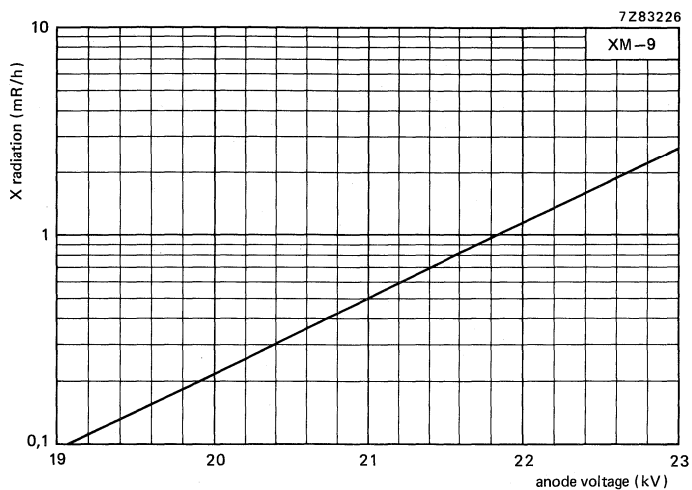

Fig.1 X-radiation limit curve according to JEDEC94, at a constant anode current of 250 μ A, measured according to TEPAC103A.

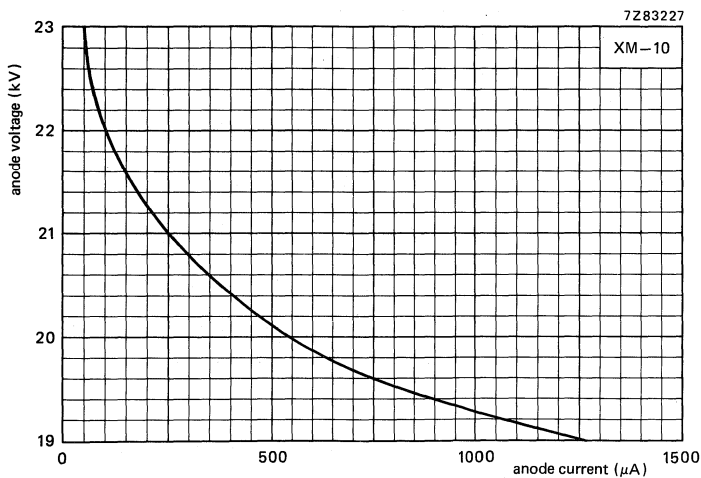

Fig.2 0.5 mR/h isoexposure-rate limit curve, according to JEDEC94, measured according to TEPAC103A.

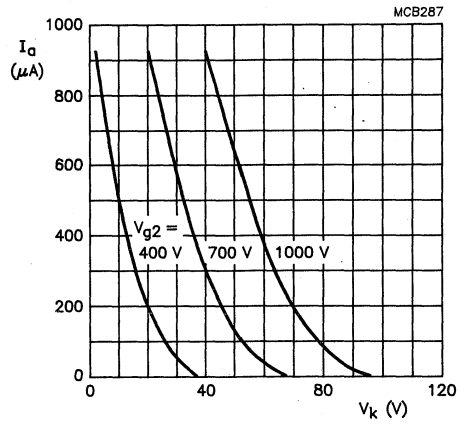

Fig.3 Anode current as a function of cathode voltage.
Cathode drive; $V_{a,g3,g5} = 14$ kV.

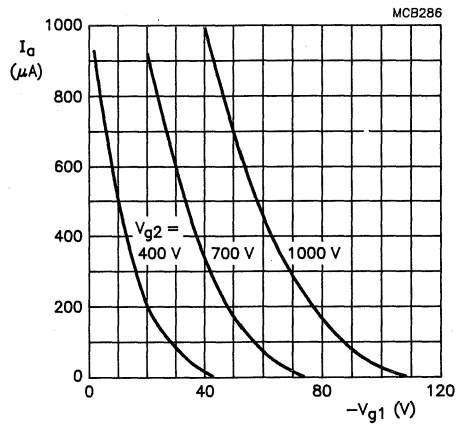

Fig.4 Anode current as a function of grid 1 voltage.
Grid drive; $V_{a,g3,g5} = 14$ kV.

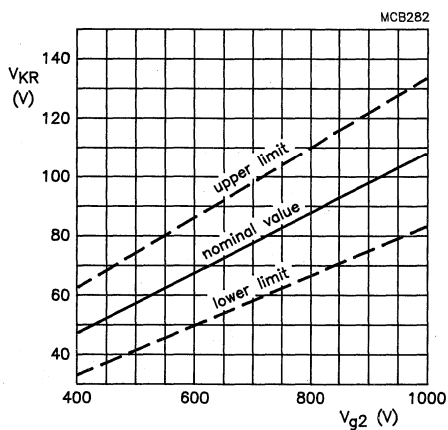

Fig.5 Limits of cathode cut-off voltage as a function of grid 2 voltage. Cathode drive; $V_{a,g3,g5} = 14$ kV.

$$\frac{\Delta V_{KR}}{\Delta V_{a,g3,g5}} = 0.9 \times 10^{-3}$$

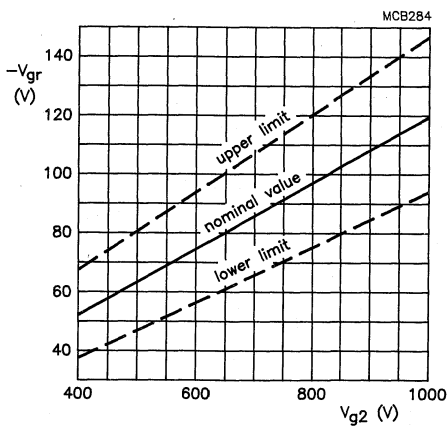
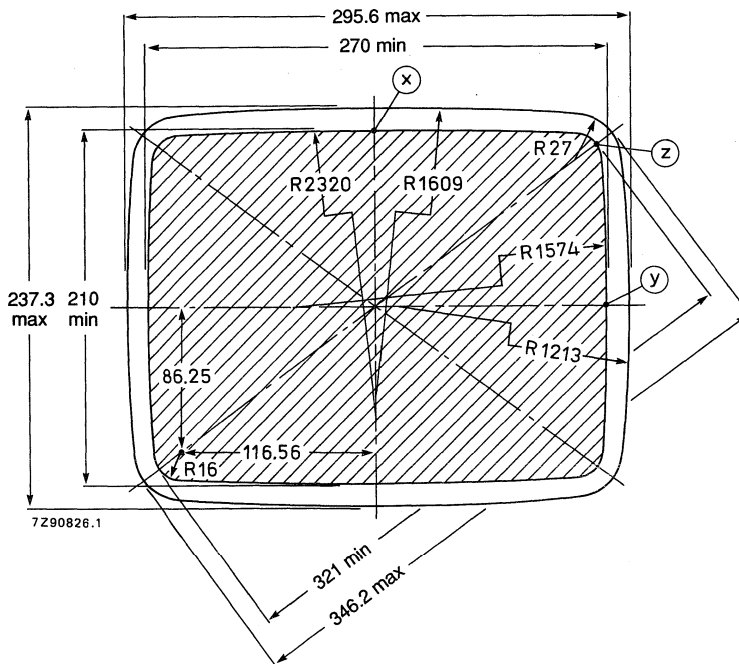
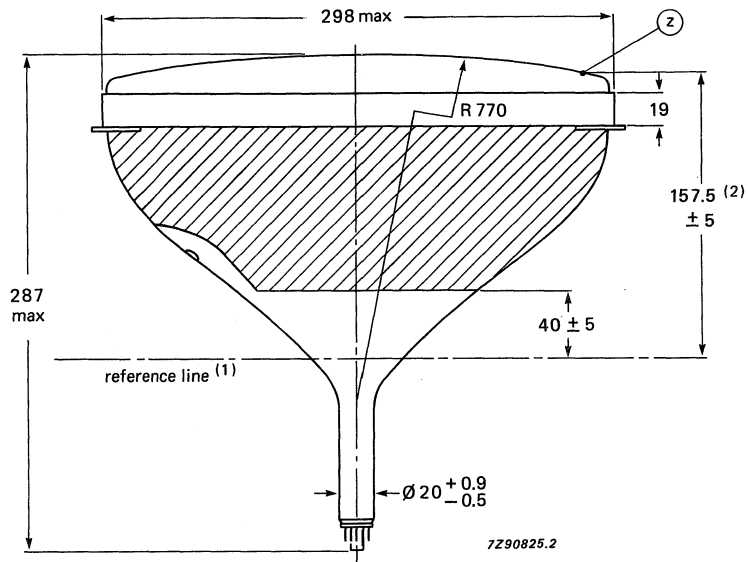

Fig.6 Limits of grid 1 cut-off voltage as a function of grid 2 voltage. Cathode drive; $V_{a,g3,g5} = 14$ kV.

$$\frac{\Delta V_{GR}}{\Delta V_{a,g3,g5}} = 0.9 \times 10^{-3}$$

DIMENSIONAL DATA

Dimensions in mm



(1) The reference line is determined by the plane of the upper edge of reference line gauge D when the gauge is resting on the cone.

(2) If NEG type, this value changes to; 159.6 ± 5 .

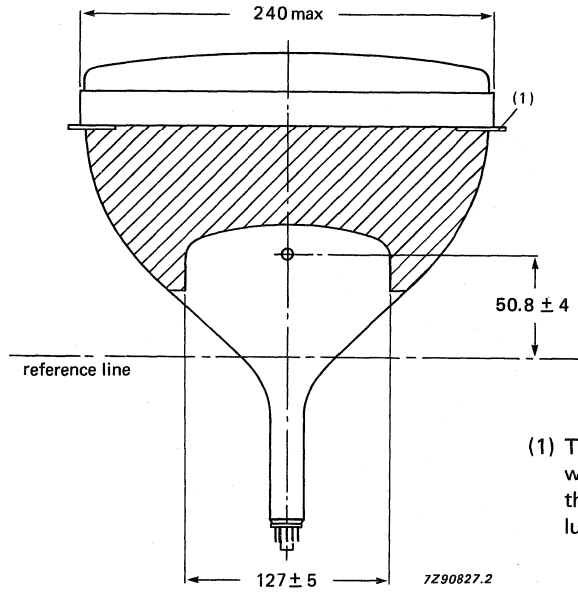

Fig.9.

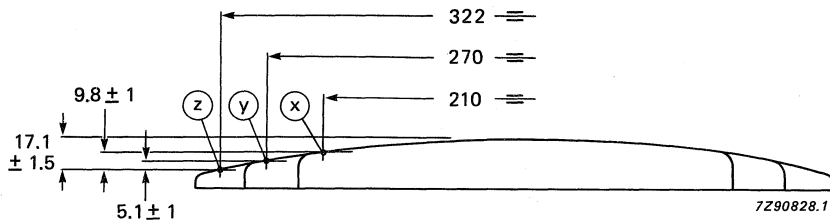

Fig.10 Screen reference points.

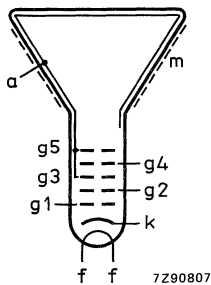

Fig.11 Electrode configuration.

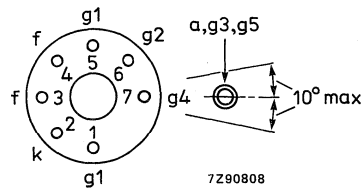

Fig.12 Pin arrangement.

Front view of tube M32EAB

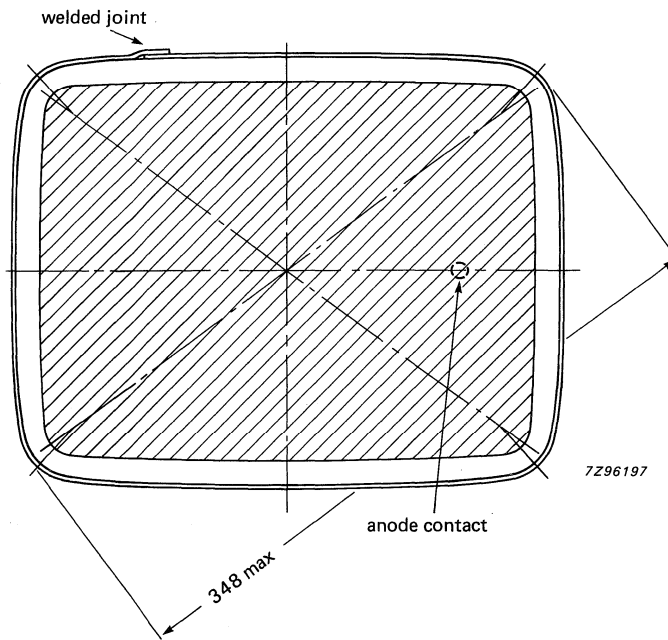

Fig.13 Tube front view with rimband.

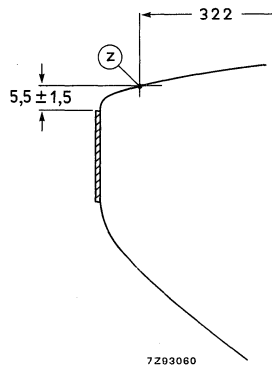

Fig.14 Rimband position.

Front view and lug dimensions of tube M32EAK

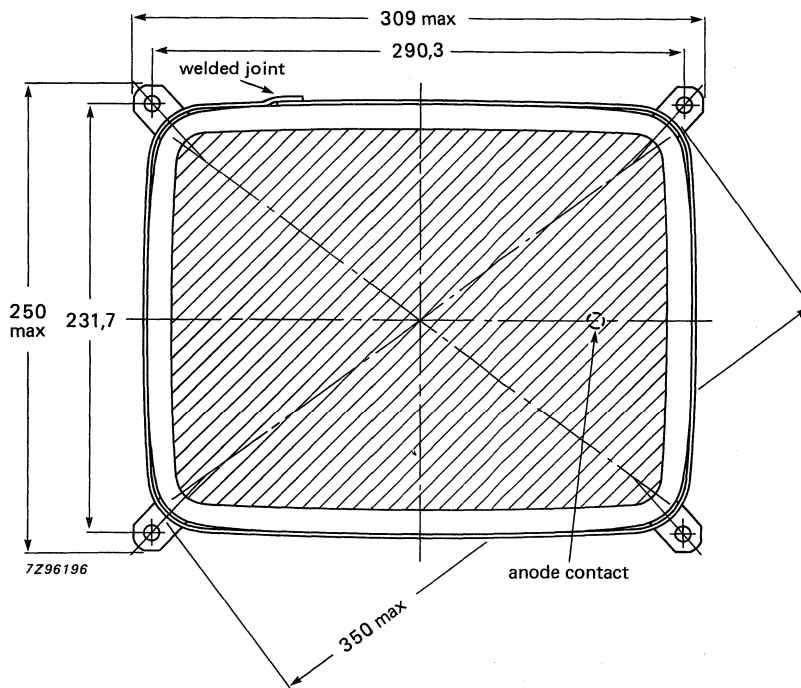

Fig.15 Tube mounting dimensions; front view.

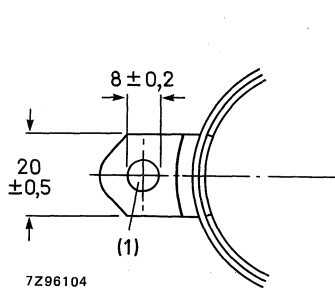

Fig.16 Lug dimensions.

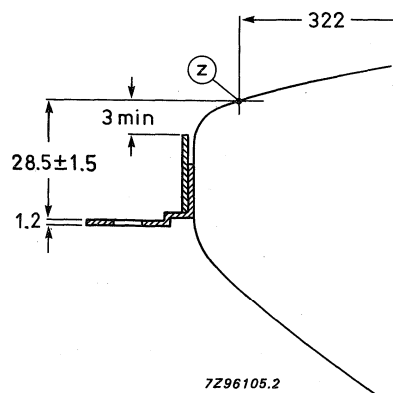

Fig.17 Lug position.

(1) The mounting screws in the cabinet must be situated inside a circle of 5 mm diameter drawn around the true geometrical positions i.e. at the corners of a rectangle of 290.3 mm x 231.7 mm.

Front view and lug dimensions of tube M32ECD

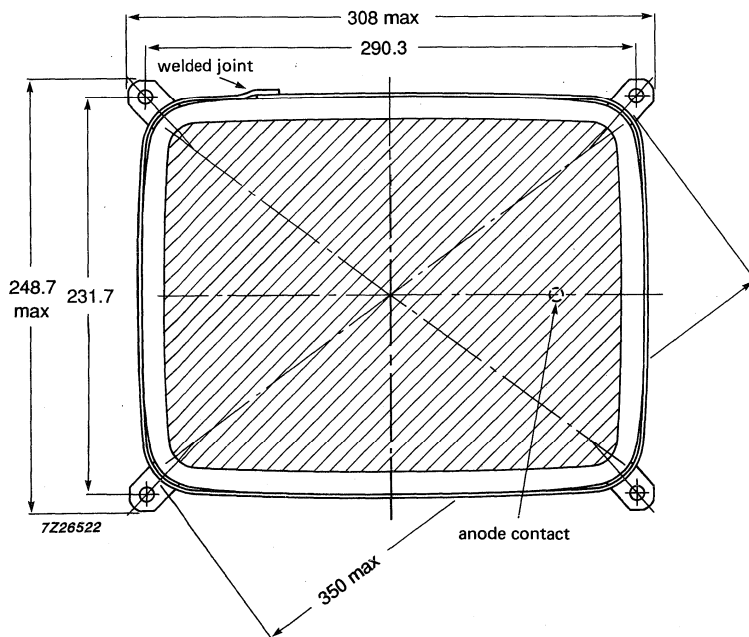

Fig.18 Tube mounting dimensions; front view.

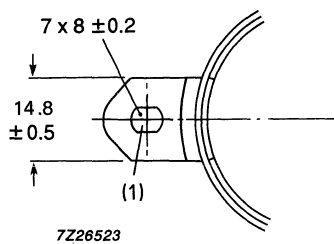

Fig.19 Lug dimensions.

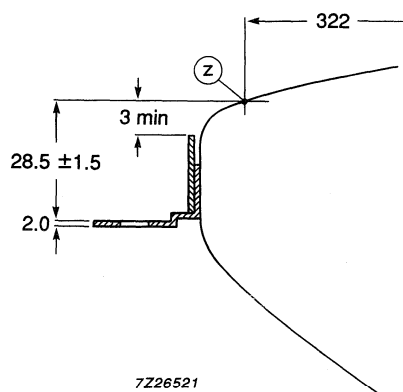

Fig.20 Lug position.

(1) The mounting screws in the cabinet must be situated inside a circle of 4 mm diameter drawn around the true geometrical positions i.e. at the corners of a rectangle of 290.3 mm x 231.7 mm.

Maximum cone contour

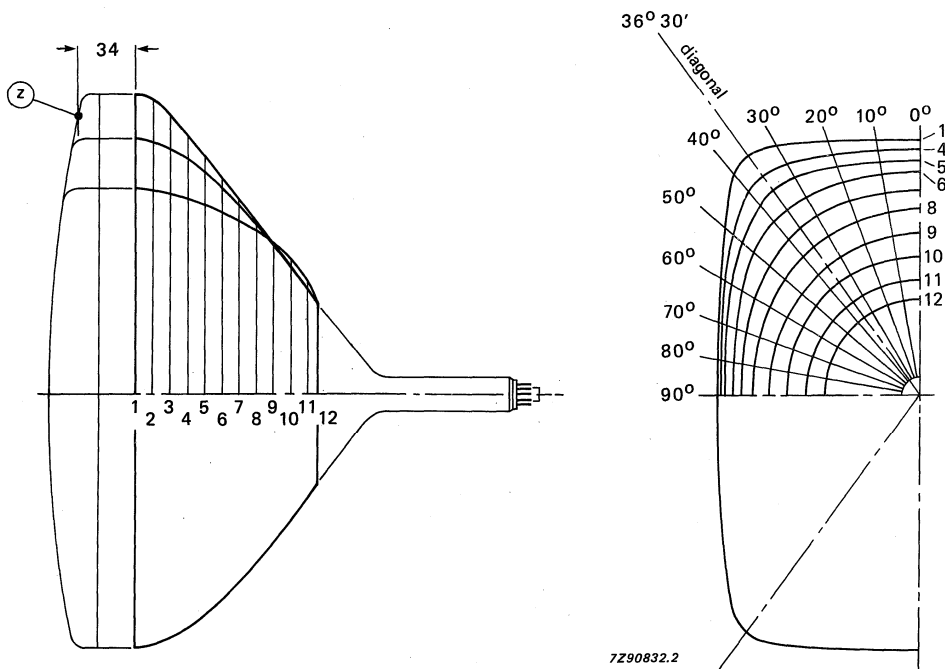

Fig.18 Cone contour.

Table 1 Cone contour data

sec- tion	nom. distance from section 1	max. distance from centre										
		0°	10°	20°	30°	diag.	40°	50°	60°	70°	80°	90°
1	0	148,0	150,1	156,5	167,9	173,6	172,0	152,3	136,3	126,5	121,1	119,4
2	10	146,1	148,2	154,6	165,4	171,0	169,6	150,9	135,2	125,4	120,1	118,4
3	20	142,4	144,3	150,1	158,4	161,6	160,4	146,3	132,0	122,8	117,7	116,1
4	30	136,7	138,4	143,1	148,8	150,2	149,2	139,4	127,6	119,2	114,5	113,0
5	40	128,9	130,3	133,9	137,6	138,3	137,6	131,2	122,2	115,0	110,7	109,3
6	50	119,5	120,6	123,2	125,7	126,2	125,8	122,0	115,8	110,0	106,3	105,1
7	60	109,2	110,1	111,8	113,5	113,9	113,8	111,9	108,1	104,1	101,1	100,1
8	70	98,7	99,2	100,2	101,2	101,5	101,6	100,9	99,1	96,8	94,9	94,1
9	80	87,6	87,7	88,1	88,6	88,9	89,0	89,0	88,6	87,8	86,9	86,4
10	90	75,5	75,4	75,4	75,6	75,7	75,8	76,1	76,3	76,3	76,2	76,1
11	100	62,0	62,0	61,8	61,8	61,8	61,9	62,0	62,2	62,4	62,5	62,5
12	105,7	51,5	51,5	51,5	51,5	51,5	51,5	51,5	51,5	51,5	51,5	51,5

FLAT HIGH RESOLUTION MONOCHROME MONITOR TUBES

- For Data Graphic Displays
- 90° deflection angle
- 34 cm (14 in) face diagonal; rectangular glass
- 1520 mm radius of screen curvature
- 20 mm neck diameter
- Integral implosion protection

QUICK REFERENCE DATA

Deflection angle	90°
Face diagonal	34 cm (14 in)
Overall length	max. 282 mm
Neck diameter	20 mm
Heating	12 V/130 mA
Quick heating cathode	with a typical tube a legible picture will appear within 5 s
Grid 2 voltage	700 V
Anode voltage	14 kV
Resolution	approx. 1300 lines

APPLICATION

This high resolution tube is for alpha-numeric and graphic display applications, such as computer terminals, small business computers, etc.

AVAILABLE VERSIONS

The following versions are available: M32EBJ and M32EBL.

The tubes can be supplied with different phosphors and anti-reflective treatments, see "High resolution monochrome monitor tubes, General".

Differences between the tubes can be found under 'Dimensional data'.

ELECTRICAL DATA

Focusing method	electrostatic
Deflection method	magnetic
Deflection angles	
diagonal	approx. 90°
horizontal	approx. 79°
vertical	approx. 65°
Interelectrode capacitances	
cathode to all other electrodes	max. 5 pF
grid 1 to all other electrodes	max. 7 pF
Capacitance of external conductive coating to anode*	max. 1400 pF min. 800 pF
Capacitance of external conductive coating to anode**	max. 1050 pF min. 450 pF
Capacitance of anode to implosion protection hardware**	approx. 150 pF
Heater voltage	12 V
Heater current at 12 V	130 mA

OPTICAL DATA

Phosphor type	see "High resolution mono-chrome monitor tubes, General"
Light transmission at screen centre	
tube with normal tinted face glass	approx. 42%
tube with dark tinted face glass	approx. 30%

RASTER CENTRING

The field intensity perpendicular to the tube axis should be adjustable from 0 to 800 A/m. For optimum overall sharpness it is recommended to centre the raster electrically via the deflection coils.

* Implosion protection hardware connected to external conductive coating.

** Implosion protection hardware not connected to external conductive coating.

FLAT

High resolution monochrome monitor tubes

**M32EBJ
M32EBL****MECHANICAL DATA** (see also the figures under Dimensional Data)

Overall length	max. 282 mm
Greatest dimensions of tube	
diagonal	348,5 mm
width	298 mm
height	240 mm
Minimum useful screen dimensions (projected)	
diagonal	319 mm
horizontal axis	267 mm
vertical axis	208 mm
area	554 cm ²
Implosion protection	T-band/rimband
Bulb	EIAJ-JB340AH03 or EIAJ-JB340AH04
Bulb contact designation	IEC 67-III-2, EIAJ1-21
Base designation	EIA-E7-91
Basing	7GR
Mass	approx. 3,9 kg

RATINGS (Absolute Maximum System)

Unless otherwise specified voltage values are positive and measured with respect to grid 1.

Anode voltage	max. 16 kV min. 10 kV
Grid 4 (focusing electrode) voltage	-200 to + 1000 V
Grid 2 voltage	max. 1000 V min. 400 V
Anode current	
long-term average value	max. 130 μ A
peak value	max. 300 μ A
Cathode voltage, positive peak value	max. 400 V
Heater voltage	12 V +5/-10%
Cathode-to-heater voltage	max. 100 V

* For maximum cathode life it is recommended that the heater supply be regulated at 12 V ^{+0%}_{-5%}.

CIRCUIT DESIGN VALUES

Grid 4 current	
positive	max. 25 μ A
negative	max. 25 μ A
Grid 2 current	
positive	max. 5 μ A
negative	max. 5 μ A

MAXIMUM CIRCUIT VALUES

Resistance between cathode and heater	max. 1 M Ω
Impedance between cathode and heater	max. 0,1 M Ω
Grid 1 circuit resistance	max. 1,5 M Ω
Grid 1 circuit impedance	max. 0,5 M Ω

TYPICAL OPERATING CONDITIONS

Cathode drive; voltages specified with respect to grid 1

Anode voltage	14 kV
Grid 4 (focusing electrode) voltage	0 to 300 V*
Grid 2 voltage	700 V
Cathode cut-off voltage	57 to 97 V**

Grid drive; voltages specified with respect to cathode

Anode voltage	14 kV
Grid 4 (focusing electrode) voltage	0 to 300 V*
Grid 2 voltage	700 V
Grid 1 cut-off voltage	65 to 107 V**

RESOLUTION

The resolution is approx. 1300 lines. It is measured at the screen centre:

- with shrinking raster method,
- at light output 68,5 cd/m² (20 foot lambert) and raster dimensions 237 mm x 178 mm,
- at $V_{g2} = 700$ V and anode voltage = 14 kV,
- with phosphor type WW,
- with normal tinted face glass, without anti-glare treatment of screen surface.

X-RADIATION CHARACTERISTIC

X-radiation emitted will not exceed 0,5 mR/h throughout the useful life of the tube, when operated within the given ratings.

* Measured at screen centre on spot at anode current = 250 μ A (peak), anode voltage = 14 kV, grid 2 voltage = 700 V.

Dynamic focus (only for optimization): Typical correction for a video field of H x V = 237 mm x 178 mm:
line parabola 200 V,
field parabola 100 V.

** Visual extinction of focused raster.

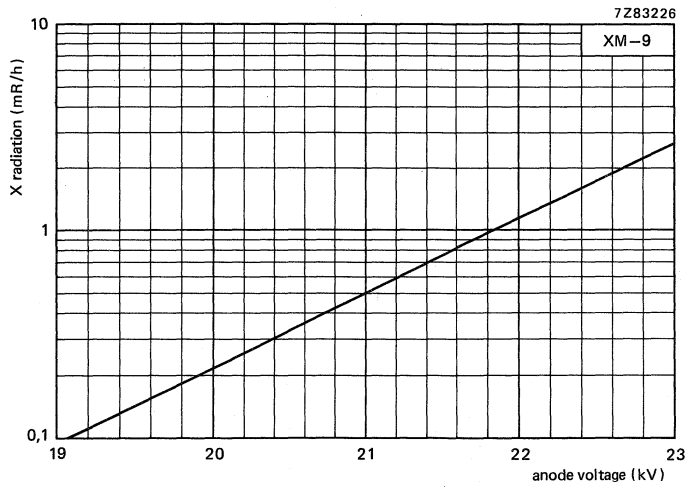

Fig.1 X-radiation limit curve according to JEDEC94, at a constant anode current of 250 μ A, measured according to TEPAC103A.

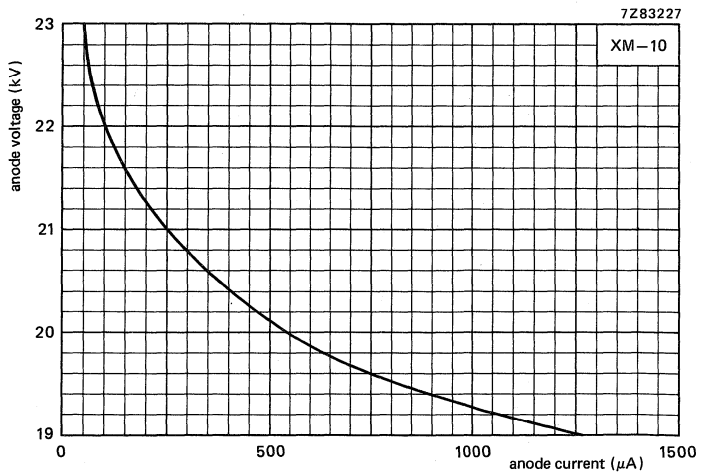

Fig.2 0,5 mR/h isoexposure-rate limit curve, according to JEDEC94, measured according to TEPAC103A.

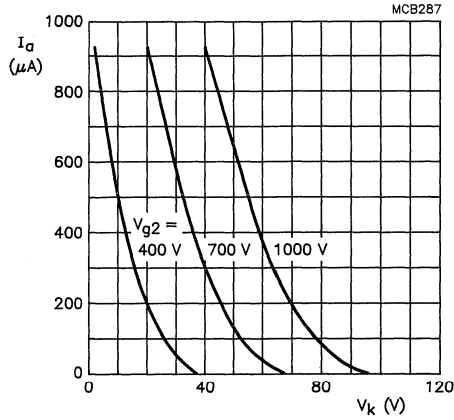

Fig.3 Anode current as a function of cathode voltage.
Cathode drive; $V_{a,g3,g5} = 14$ kV.

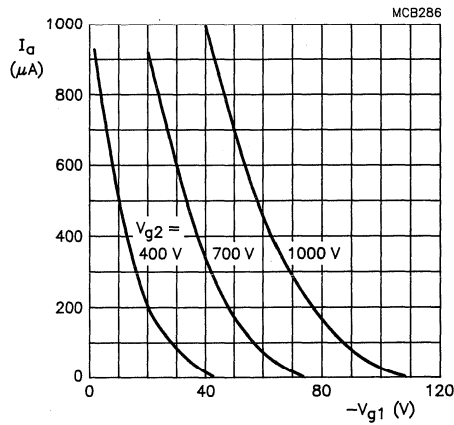

Fig.4 Anode current as a function of grid 1 voltage.
Grid drive; $V_{a,g3,g5} = 14$ kV.

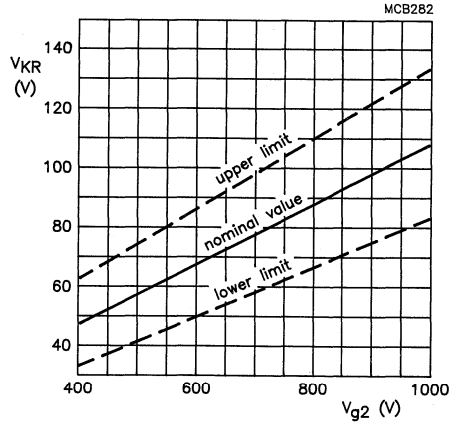

Fig.5 Limits of cathode cut-off voltage as a function of grid 2 voltage.
Cathode drive; $V_{a,g3,g5} = 14$ kV.

$$\frac{\Delta V_{KR}}{\Delta V_{a,g3,g5}} = 0.9 \times 10^{-3}.$$

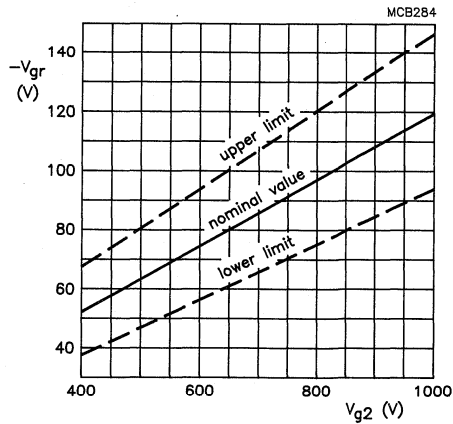
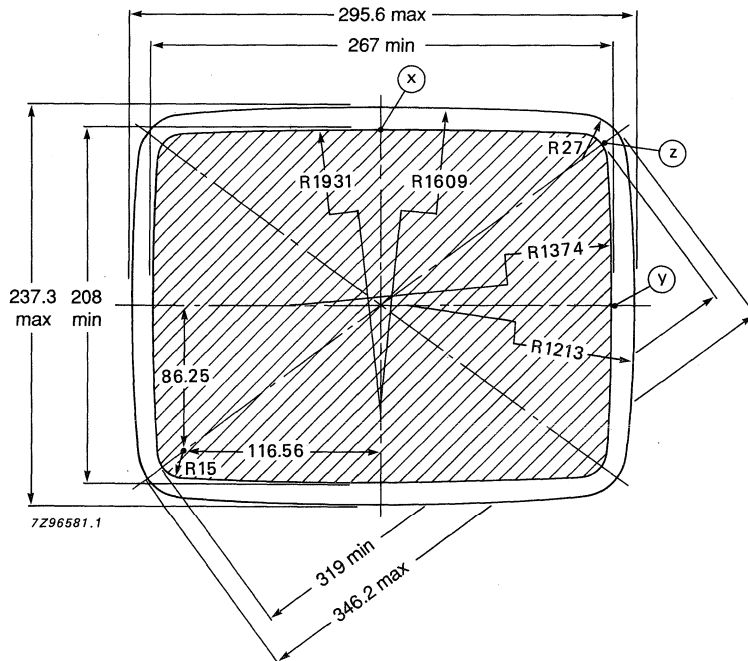
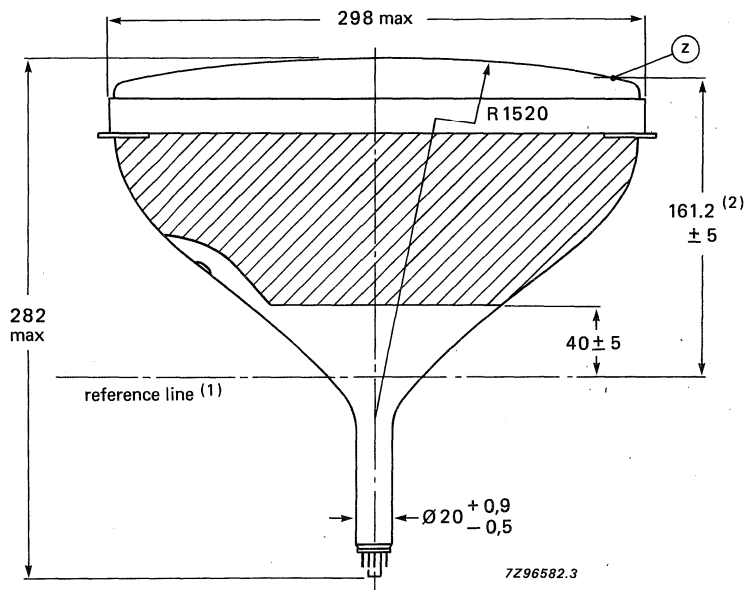

Fig.6 Limits of grid 1 cut-off voltage as a function of grid 2 voltage.
Grid drive; $V_{a,g3,g5} = 14$ kV.

$$\frac{\Delta V_{GR}}{\Delta V_{a,g3,g5}} = 0.9 \times 10^{-3}.$$

DIMENSIONAL DATA

Dimensions in mm



- (1) The reference line is determined by the plane of the upper edge of reference line gauge D when the gauge is resting on the cone.
- (2) If NEG type, this value changes to 162.9 ± 5 .

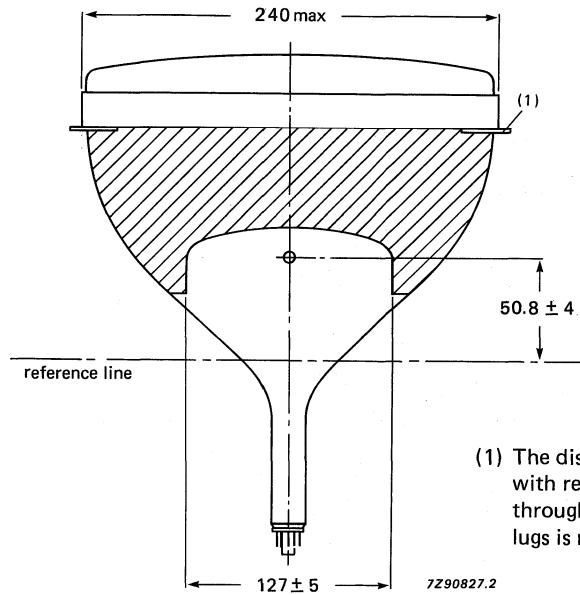

Fig. 9.

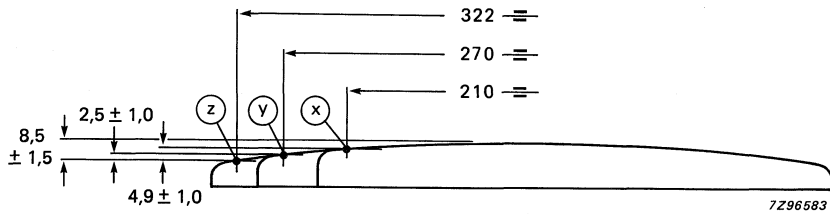

Fig. 10 Screen reference points.

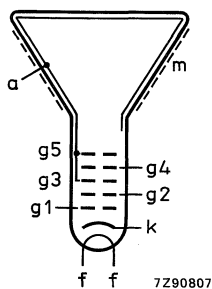

Fig. 11 Electrode configuration.

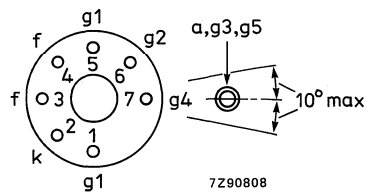

Fig. 12 Pin arrangement.

Front view of tube M32EBJ

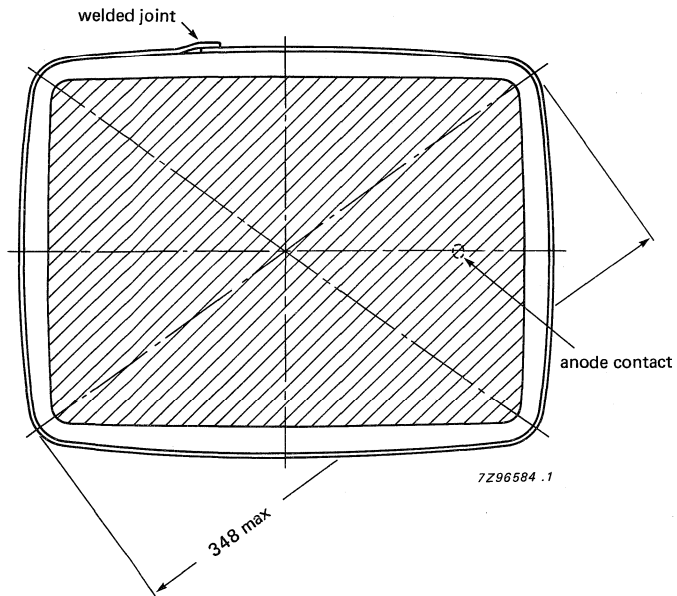

Fig.13 Tube mounting dimensions; front view.

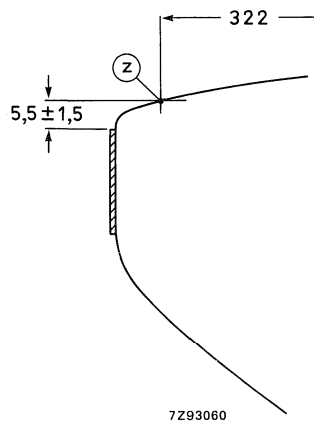

Fig.14 Lug position.

Front view and lug dimensions of tube M32EBL

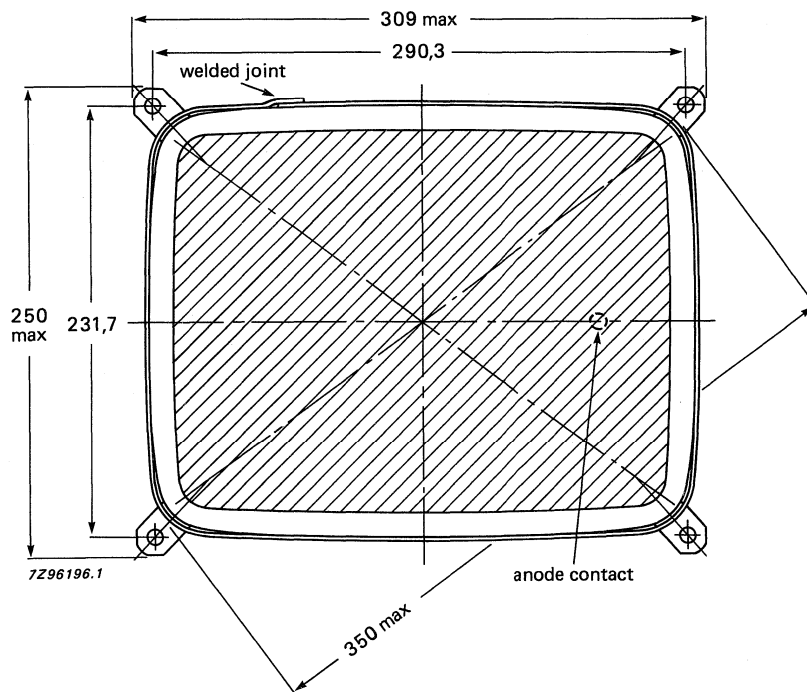

Fig.15 Tube mounting dimensions; front view.

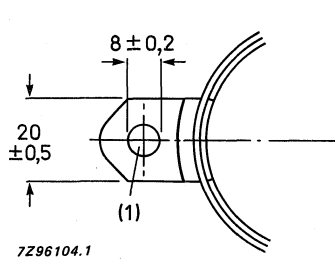

Fig.16 Lug dimensions.

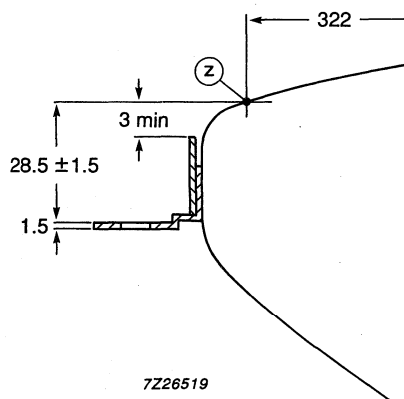

Fig.17 Lug position.

(1) The mounting screws in the cabinet must be situated inside a circle of 5 mm diameter drawn around the true geometrical positions i.e. at the corners of a rectangle of 290.3 mm x 231.7 mm.

Maximum cone contour

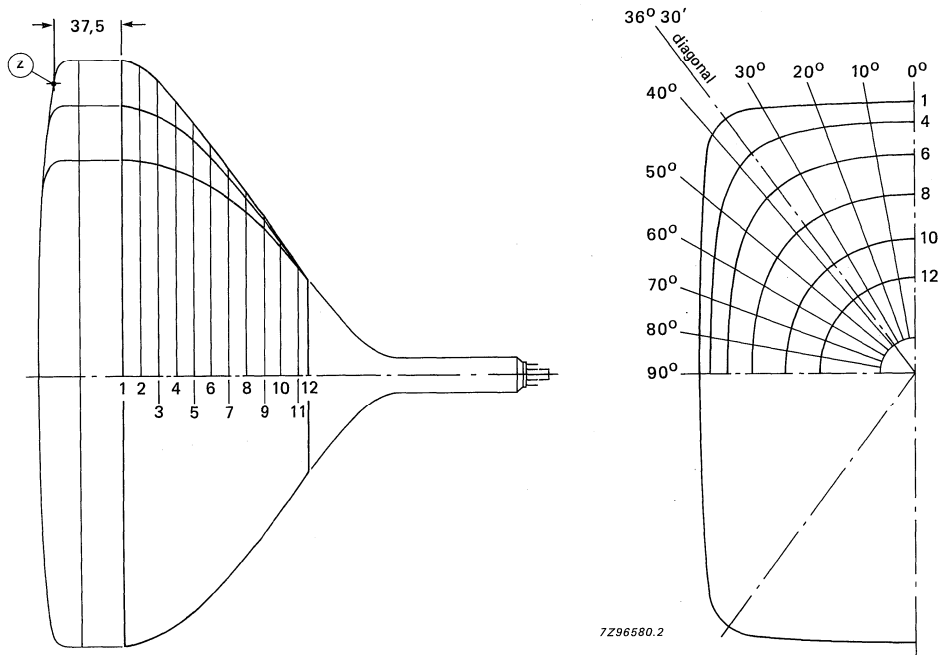

Fig.18 Cone contour.

sec- tion	nom. distance from section 1	max. distance from centre										
		0,00	10,00	20,00	30,00	36,50	40,00	50,00	60,00	70,00	80,00	90,00
1	0	147,75	149,80	156,19	167,63	173,43	171,77	151,39	135,49	125,67	120,31	118,60
2	10	146,15	148,17	154,42	165,14	170,27	168,65	149,73	134,26	124,62	119,34	117,66
3	20	142,36	144,25	149,91	158,20	161,07	159,63	145,28	131,24	122,14	117,11	115,50
4	30	136,49	138,18	142,87	148,45	149,74	148,65	138,71	126,91	118,58	113,89	112,39
5	40	128,75	130,16	133,72	137,36	137,91	137,07	130,27	121,08	113,85	109,61	108,23
6	50	119,35	120,49	123,12	125,56	125,86	125,30	120,77	113,97	108,01	104,28	103,05
7	60	108,70	109,58	111,51	113,24	113,50	113,19	110,37	105,66	101,04	97,92	96,84
8	70	97,64	98,27	99,58	100,70	100,90	100,74	99,10	96,11	92,85	90,43	89,53
9	80	86,29	86,69	87,45	88,06	88,14	88,04	87,11	85,36	83,31	81,62	80,93
10	90	74,00	74,26	74,72	75,09	75,14	75,10	74,60	73,64	72,44	71,37	70,90
11	100	60,59	60,78	61,12	61,41	61,51	61,52	61,35	60,93	60,34	59,78	59,50
12	110	51,89	51,97	52,09	52,20	52,23	52,24	52,19	52,07	51,90	51,73	51,64

DEVELOPMENT DATA

This data sheet contains advance information and specifications are subject to change without notice.

M32EBM
M32EBN

FLAT HIGH RESOLUTION MONOCHROME MONITOR TUBES

- For Data Graphic Displays
- 90° deflection angle
- 34 cm (14 in) face diagonal; rectangular glass
- 1520 mm radius of screen curvature
- 20 mm neck diameter
- Integral implosion protection

QUICK REFERENCE DATA

Deflection angle	90°
Face diagonal	34 cm (14 in)
Overall length	max. 282 mm
Neck diameter	20 mm
Heating	12 V/75 mA
Grid 2 voltage	700 V
Anode voltage	14 kV
Resolution	approx. 1300 lines

APPLICATION

These high resolution tubes are for alphanumeric and graphic display applications, such as computer terminals, small business computers, etc.

AVAILABLE VERSIONS

The following versions are available: M32EBM and M32EBN.

The tubes can be supplied with different phosphors and anti-reflective treatments, see "High resolution monochrome monitor tubes, General".

Differences between the tubes can be found under 'Dimensional Data'.

ELECTRICAL DATA

Focusing method	electrostatic
Deflection method	magnetic
Deflection angles	
diagonal	approx. 90°
horizontal	approx. 79°
vertical	approx. 65°
Interelectrode capacitances	
cathode to all other electrodes	max. 5 pF
grid 1 to all other electrodes	max. 8 pF
Capacitance of external conductive coating to anode*	max. 1400 pF min. 800 pF
Capacitance of external conductive coating to anode**	max. 1050 pF min. 450 pF
Capacitance of anode to implosion protection hardware**	approx. 150 pF
Heater voltage	12 V
Heater current at 12 V	75 mA

OPTICAL DATA

Phosphor type	see "High resolution mono-chrome monitor tubes, General"
Light transmission at screen centre	
tube with normal tinted face glass	approx. 42%
tube with dark tinted face glass	approx. 30%

RASTER CENTRING

The field intensity perpendicular to the tube axis should be adjustable from 0 to 800 A/m. For optimum overall sharpness it is recommended to centre the raster electrically via the deflection coils.

* Implosion protection hardware connected to external conductive coating.

** Implosion protection hardware not connected to external conductive coating.

MECHANICAL DATA (see also the figures under Dimensional Data)

Overall length	max. 282 mm
Greatest dimensions of tube	
diagonal	348,5 mm
width	298 mm
height	240 mm
Minimum useful screen dimensions (projected)	
diagonal	319 mm
horizontal axis	267 mm
vertical axis	208 mm
area	554 cm ²
Implosion protection	T-band/rimband
Bulb	EIAJ-JB340AH03 or EIAJ-JB340AH04
Bulb contact designation	IEC 67-III-2, EIAJ1-21
Base designation	EIA-E7-91
Basing	7GR
Mass	approx. 3,9 kg

DEVELOPMENT DATA**RATINGS** (Absolute Maximum System)

Unless otherwise specified voltage values are positive and measured with respect to grid 1.

Anode voltage	max. 16 kV min. 10 kV
Grid 4 (focusing electrode) voltage	−200 to + 1000 V
Grid 2 voltage	max. 1000 V min. 400 V
Anode current	
long-term average value	max. 130 μ A
peak value	max. 300 μ A
Cathode voltage, positive peak value	max. 400 V
Heater voltage	12 V +5/−10%
Cathode-to-heater voltage	max. 100 V

* For maximum cathode life it is recommended that the heater supply be regulated at 12 V $\begin{matrix} +0\% \\ -5\% \end{matrix}$.

CIRCUIT DESIGN VALUES

Grid 4 current	
positive	max. 25 μ A
negative	max. 25 μ A
Grid 2 current	
positive	max. 5 μ A
negative	max. 5 μ A

MAXIMUM CIRCUIT VALUES

Resistance between cathode and heater	max. 1 M Ω
Impedance between cathode and heater	max. 0,1 M Ω
Grid 1 circuit resistance	max. 1,5 M Ω
Grid 1 circuit impedance	max. 0,5 M Ω

TYPICAL OPERATING CONDITIONS

Cathode drive; voltages specified with respect to grid 1

Anode voltage	14 kV
Grid 4 (focusing electrode) voltage	0 to 300 V*
Grid 2 voltage	700 V
Cathode cut-off voltage	57 to 97 V**

Grid drive; voltages specified with respect to cathode

Anode voltage	14 kV
Grid 4 (focusing electrode) voltage	0 to 300 V*
Grid 2 voltage	700 V
Grid 1 cut-off voltage	65 to 107 V**

RESOLUTION

The resolution is approx. 1300 lines. It is measured at the screen centre:

- with shrinking raster method,
- at light output 68,5 cd/m² (20 foot lambert) and raster dimensions 237 mm x 178 mm,
- at $V_{g2} = 700$ V and anode voltage = 14 kV,
- with phosphor type WW,
- with normal tinted face glass, without anti-glare treatment of screen surface.

X-RADIATION CHARACTERISTIC

X-radiation emitted will not exceed 0,5 mR/h throughout the useful life of the tube, when operated within the given ratings.

* Measured at screen centre on spot at anode current = 250 μ A (peak), anode voltage = 14 kV, grid 2 voltage = 700 V.

Dynamic focus (only for optimization): Typical correction for a video field of H x V = 237 mm x 178 mm:
line parabola 200 V,
field parabola 100 V.

** Visual extinction of focused raster.

DEVELOPMENT DATA

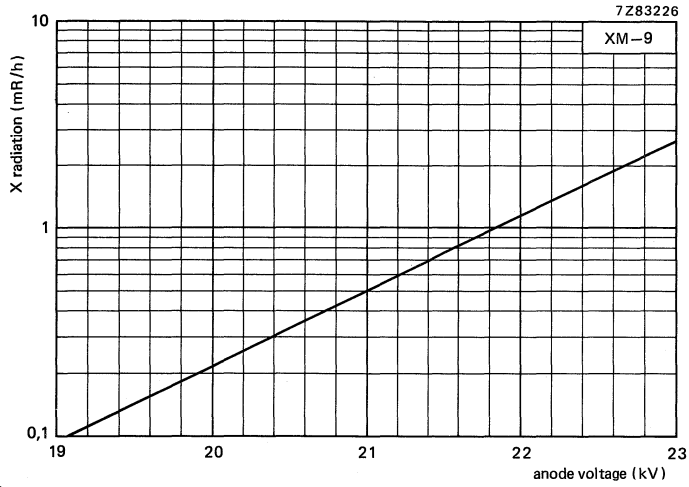

Fig. 1 X-radiation limit curve according to JEDEC94, at a constant anode current of $250 \mu\text{A}$, measured according to TEPAC103A.

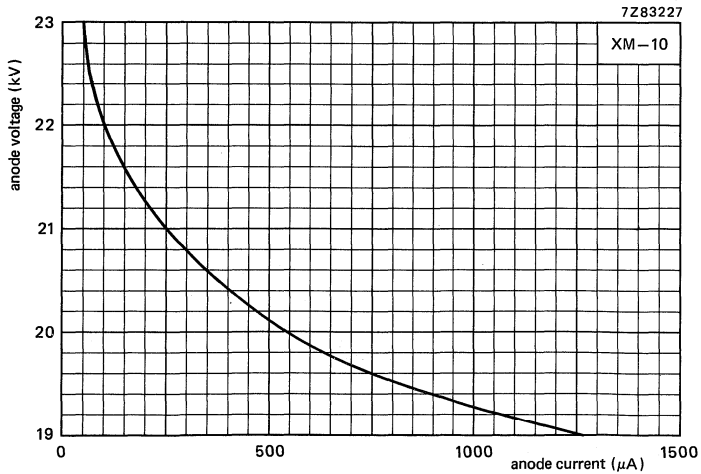

Fig. 2 0,5 mR/h isoexposure-rate limit curve, according to JEDEC94, measured according to TEPAC103A.

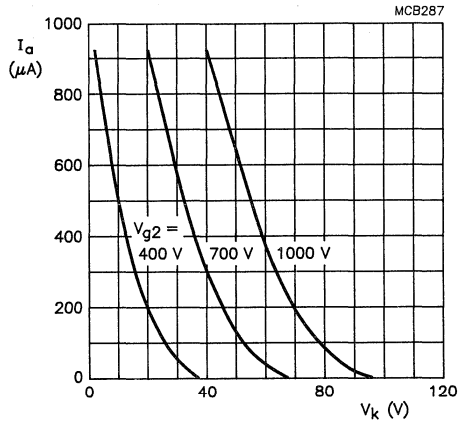

Fig. 3 Anode current as a function of cathode voltage.
Cathode drive; $V_{a,g3,g5} = 14$ kV.

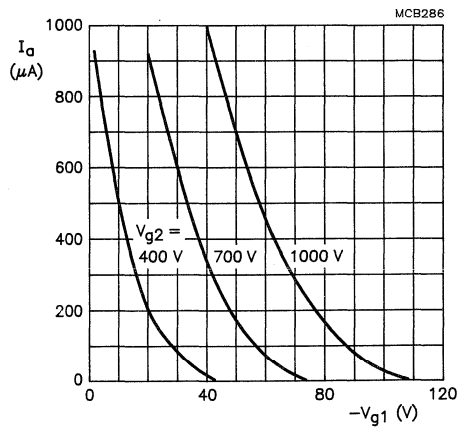

Fig. 4 Anode current as a function of grid 1 voltage.
Grid drive; $V_{a,g3,g5} = 14$ kV.

DEVELOPMENT DATA

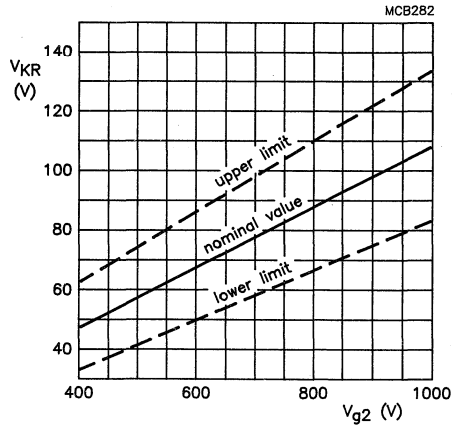

Fig. 5 Limits of cathode cut-off voltage as a function of grid 2 voltage. Cathode drive; $V_{a,g3,g5} = 14$ kV.

$$\frac{\Delta V_{KR}}{\Delta V_{a,g3,g5}} = 0.9 \times 10^{-3}$$

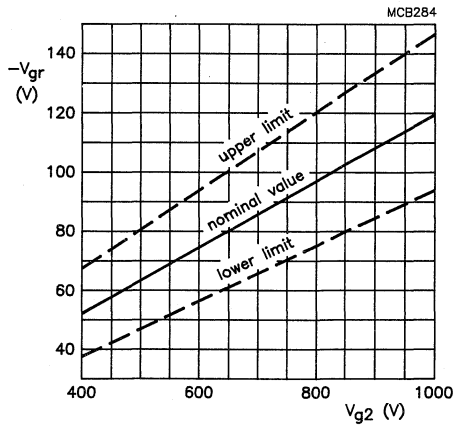
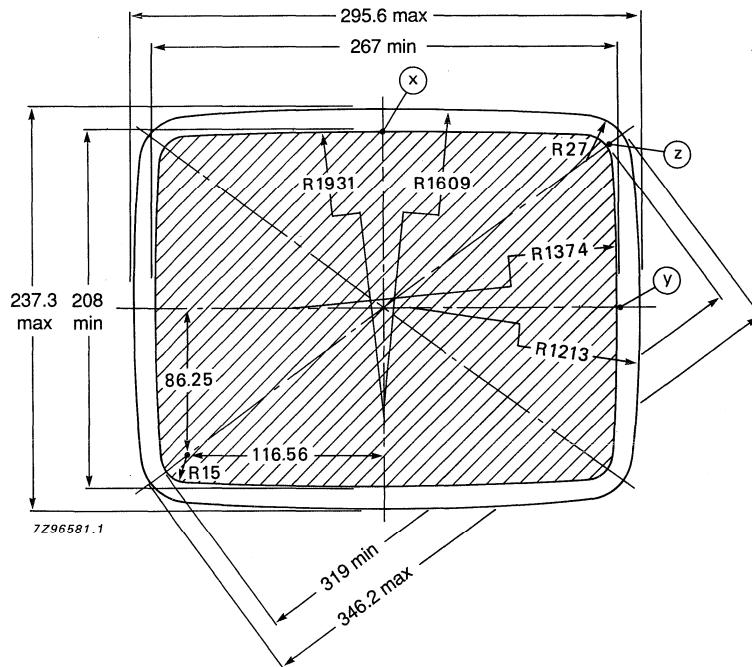
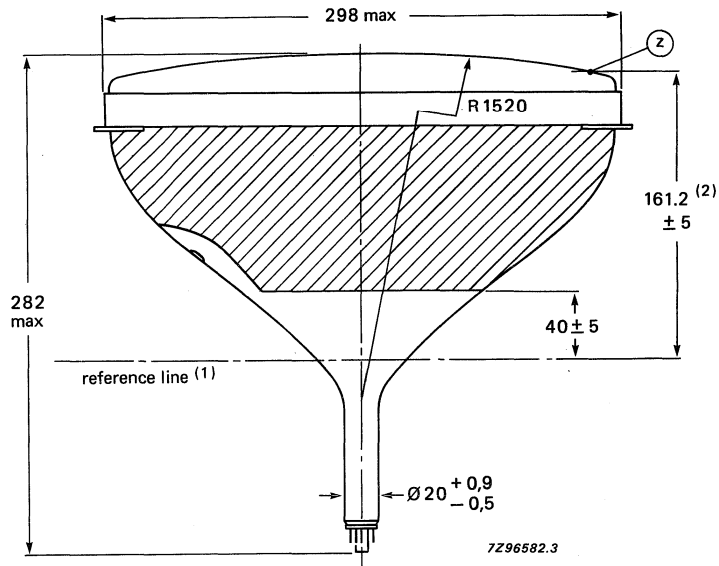

Fig. 6 Limits of grid 1 cut-off voltage as a function of grid 2 voltage. Grid drive; $V_{a,g3,g5} = 14$ kV.

$$\frac{\Delta V_{GR}}{\Delta V_{a,g3,g5}} = 0.9 \times 10^{-3}$$

DIMENSIONAL DATA

Dimensions in mm



- (1) The reference line is determined by the plane of the upper edge of reference line gauge D when the gauge is resting on the cone.
- (2) If NEG type, this value changes to 162.9 ± 5 .

DEVELOPMENT DATA

Fig. 9

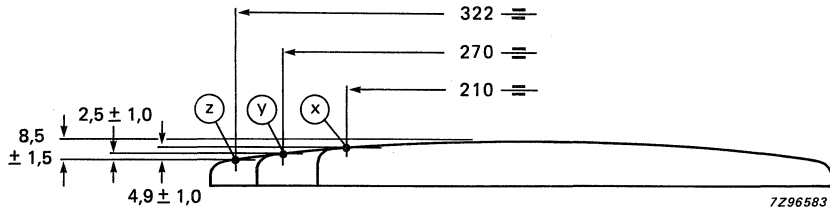
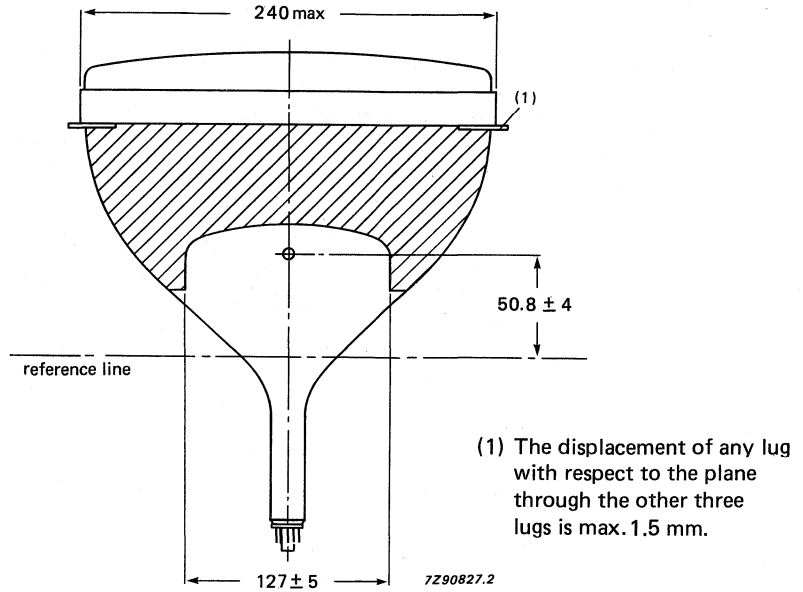

Fig. 10 Screen reference points.

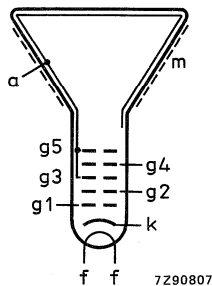

Fig. 11 Electrode configuration.

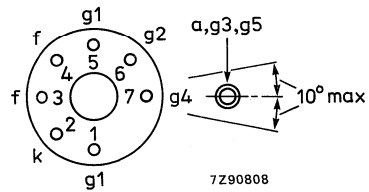

Fig. 12 Pin arrangement.

Front view of tube M32EBM

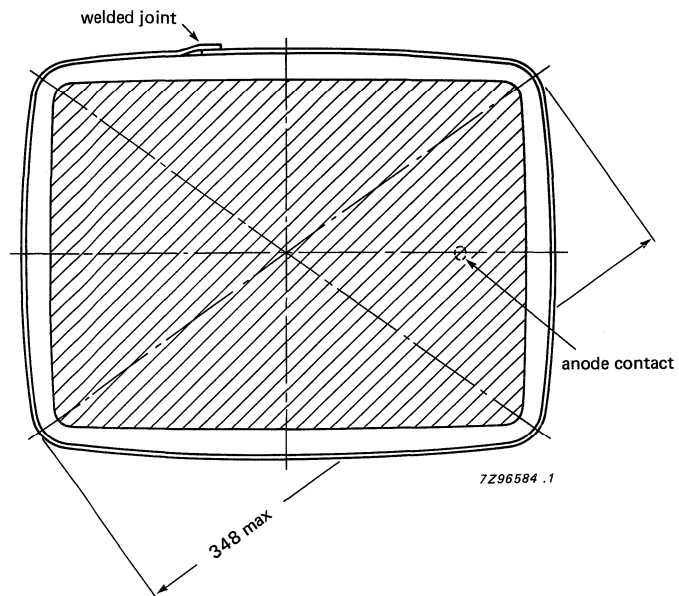

Fig. 13 Tube front view with rimband.

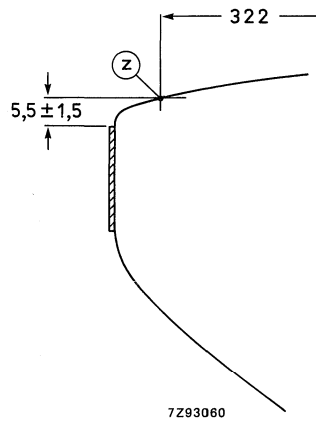

Fig. 14 Rimband position.

Front view and lug dimensions of tube M32EBN

DEVELOPMENT DATA

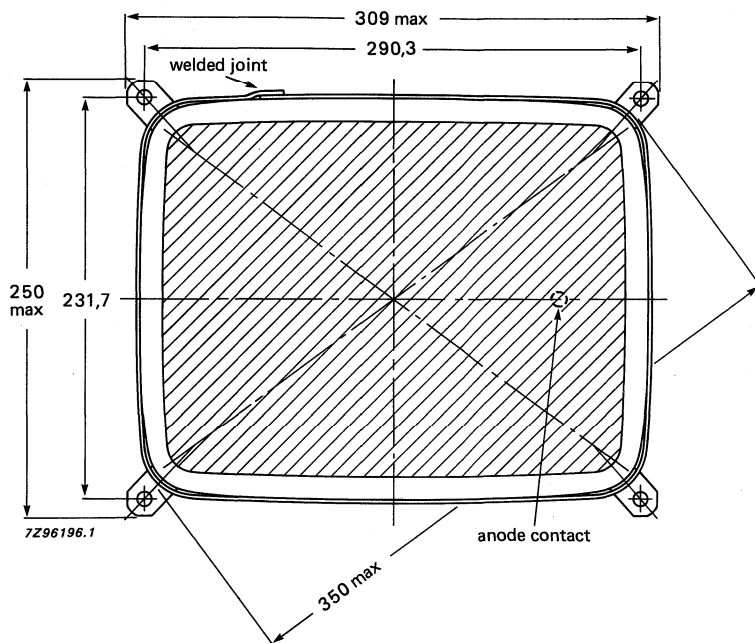

Fig. 15 Tube mounting dimensions; front view.

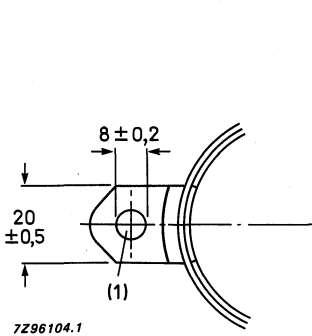

Fig. 16 Lug dimensions.

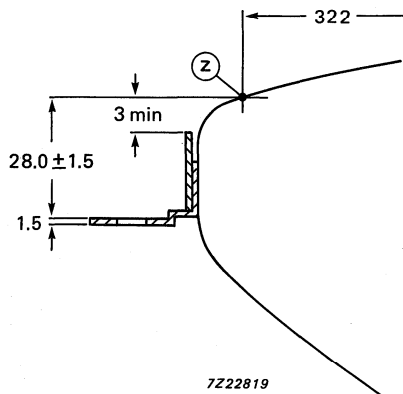

Fig. 17 Lug position.

(1) The mounting screws in the cabinet must be situated inside a circle of 5 mm diameter drawn around the true geometrical positions i.e. at the corners of a rectangle of 290,3 mm x 231,7 mm.

Maximum cone contour

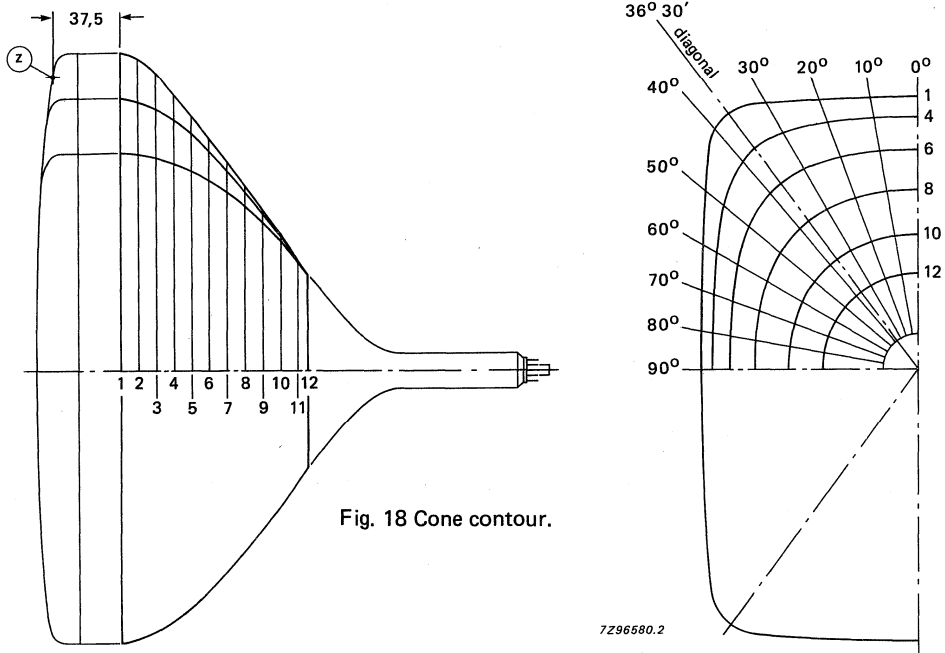

Table 1 Cone contour data

sec- tion	nom. distance from section 1	max. distance from centre										
		0,00	10,00	20,00	30,00	36,50	40,00	50,00	60,00	70,00	80,00	90,00
1	0	147,75	149,80	156,19	167,63	173,43	171,77	151,39	135,49	125,67	120,31	118,60
2	10	146,15	148,17	154,42	165,14	170,27	168,65	149,73	134,26	124,62	119,34	117,66
3	20	142,36	144,25	149,91	158,20	161,07	159,63	145,28	131,24	122,14	117,11	115,50
4	30	136,49	138,18	142,87	148,45	149,74	148,65	138,71	126,91	118,58	113,89	112,39
5	40	128,75	130,16	133,72	137,36	137,91	137,07	130,27	121,08	113,85	109,61	108,23
6	50	119,35	120,49	123,12	125,56	125,86	125,30	120,77	113,97	108,01	104,28	103,05
7	60	108,70	109,58	111,51	113,24	113,50	113,19	110,37	105,66	101,04	97,92	96,84
8	70	97,64	98,27	99,58	100,70	100,90	100,74	99,10	96,11	92,85	90,43	89,53
9	80	86,29	86,69	87,45	88,06	88,14	88,04	87,11	85,36	83,31	81,62	80,93
10	90	74,00	74,26	74,72	75,09	75,14	75,10	74,60	73,64	72,44	71,37	70,90
11	100	60,59	60,78	61,12	61,41	61,51	61,52	61,35	60,93	60,34	59,78	59,50
12	110	51,89	51,97	52,09	52,20	52,23	52,24	52,19	52,07	51,90	51,73	51,64

DEVELOPMENT DATA

This data sheet contains advance information and specifications are subject to change without notice.

M32EBY

FLAT HIGH RESOLUTION MONOCHROME MONITOR TUBE

- For Data Graphic Displays
- 90° deflection angle
- 34 cm (14 in) face diagonal; rectangular glass
- 1520 mm radius of screen curvature
- 20 mm neck diameter
- Integral implosion protection

QUICK REFERENCE DATA

Deflection angle	90°
Face diagonal	34 cm (14 in)
Overall length	max. 282 mm
Neck diameter	20 mm
Heating	12 V/130 mA
Quick heating cathode	with a typical tube a legible picture will appear within 5 s
Grid 2 voltage	700 V
Anode voltage	14 kV
Resolution	approx. 1300 lines

APPLICATION

This high resolution tube is for alpha-numeric and graphic display applications, such as computer terminals, small business computers, etc.

AVAILABLE VERSIONS

The tube can be supplied with different phosphors and anti-reflective treatments, see "High resolution monochrome monitor tubes, General".

ELECTRICAL DATA

Focusing method	electrostatic
Deflection method	magnetic
Deflection angles	
diagonal	approx. 90°
horizontal	approx. 79°
vertical	approx. 65°
Interelectrode capacitances	
cathode to all other electrodes	max. 5 pF
grid 1 to all other electrodes	max. 7 pF
Capacitance of external conductive coating to anode*	max. 1400 pF min. 800 pF
Capacitance of external conductive coating to anode**	max. 1050 pF min. 450 pF
Capacitance of anode to implosion protection hardware**	approx. 150 pF
Heater voltage	12 V
Heater current at 12 V	130 mA

OPTICAL DATA

Phosphor type	see "High resolution mono-chrome monitor tubes, General"
Light transmission at screen centre	
tube with normal tinted face glass	approx. 42%
tube with dark tinted face glass	approx. 30%

RASTER CENTRING

The field intensity perpendicular to the tube axis should be adjustable from 0 to 800 A/m. For optimum overall sharpness it is recommended to centre the raster electrically via the deflection coils.

* Implosion protection hardware connected to external conductive coating.

** Implosion protection hardware not connected to external conductive coating.

MECHANICAL DATA (see also the figures under Dimensional Data)

Overall length	max. 282 mm
Greatest dimensions of tube	
diagonal	348,5 mm
width	298 mm
height	240 mm
Minimum useful screen dimensions (projected)	
diagonal	319 mm
horizontal axis	267 mm
vertical axis	209 mm
area	554 cm ²
Implosion protection	T-band/rimband
Bulb	EIAJ-JB340AH03 or EIAJ-JB340AH04
Bulb contact designation	IEC 67-III-2, EIAJ1-21
Base designation	EIA-E7-91
Basing	7GR
Mass	approx. 3,9 kg

RATINGS (Absolute Maximum System)

Unless otherwise specified voltage values are positive and measured with respect to grid 1.

Anode voltage	max. 16 kV min. 10 kV
Grid 4 (focusing electrode) voltage	-200 to + 1000 V
Grid 2 voltage	max. 1000 V min. 400 V
Anode current	
long-term average value	max. 130 μ A
peak value	max. 300 μ A
Cathode voltage, positive peak value	max. 400 V
Heater voltage	12 V +5/-10%
Cathode-to-heater voltage	max. 100 V

DEVELOPMENT DATA

* For maximum cathode life it is recommended that the heater supply be regulated at 12 V $\begin{matrix} +0\% \\ -5\% \end{matrix}$.

CIRCUIT DESIGN VALUES

Grid 4 current	
positive	max. 25 μ A
negative	max. 25 μ A
Grid 2 current	
positive	max. 5 μ A
negative	max. 5 μ A

MAXIMUM CIRCUIT VALUES

Resistance between cathode and heater	max. 1 M Ω
Impedance between cathode and heater	max. 0,1 M Ω
Grid 1 circuit resistance	max. 1,5 M Ω
Grid 1 circuit impedance	max. 0,5 M Ω

TYPICAL OPERATING CONDITIONS

Cathode drive; voltages specified with respect to grid 1

Anode voltage	14 kV
Grid 4 (focusing electrode) voltage	0 to 300 V*
Grid 2 voltage	700 V
Cathode cut-off voltage	57 to 97 V**

Grid drive; voltages specified with respect to cathode

Anode voltage	14 kV
Grid 4 (focusing electrode) voltage	0 to 300 V*
Grid 2 voltage	700 V
Grid 1 cut-off voltage	65 to 107 V**

RESOLUTION

The resolution is approx. 1300 lines. It is measured at the screen centre:

- with shrinking raster method,
- at light output 68,5 cd/m² (20 foot lambert) and raster dimensions 237 mm x 178 mm,
- at $V_{g2} = 700$ V and anode voltage = 14 kV,
- with phosphor type WW,
- with normal tinted face glass, without anti-glare treatment of screen surface.

X-RADIATION CHARACTERISTIC

X-radiation emitted will not exceed 0,5 mR/h throughout the useful life of the tube, when operated within the given ratings.

* Measured at screen centre on spot at anode current = 250 μ A (peak), anode voltage = 14 kV, grid 2 voltage = 700 V.

Dynamic focus (only for optimization): Typical correction for a video field of H x V = 237 mm x 178 mm:
line parabola 200 V,
field parabola 100 V.

** Visual extinction of focused raster.

DEVELOPMENT DATA

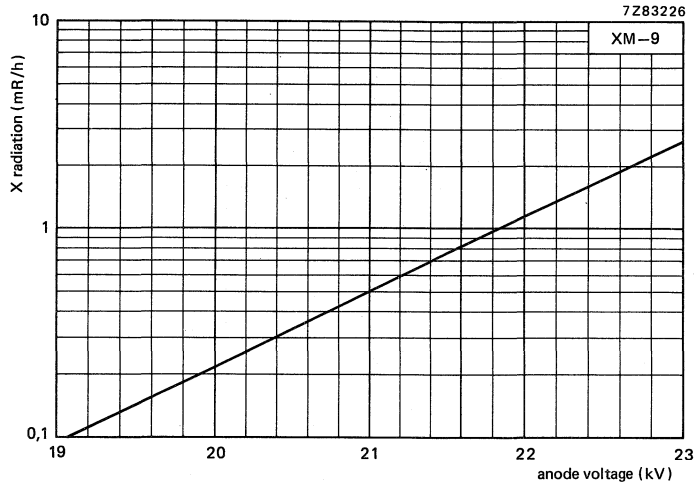

Fig. 1 X-radiation limit curve according to JEDEC94, at a constant anode current of 250 μ A, measured according to TEPAC103A.

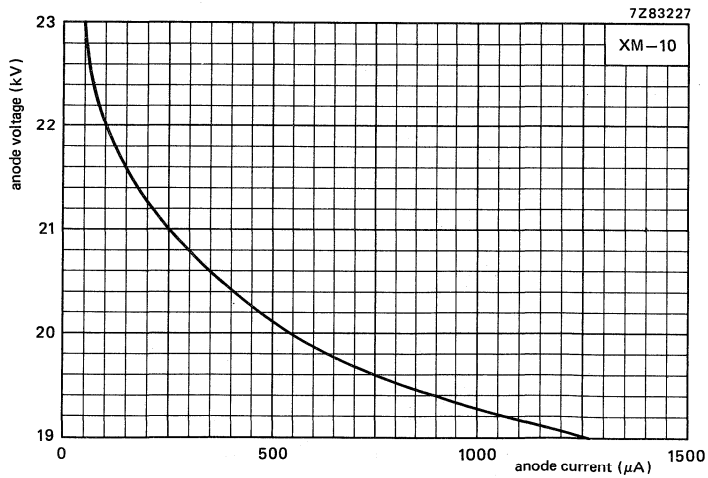

Fig. 2 0,5 mR/h isoexposure-rate limit curve, according to JEDEC94, measured according to TEPAC103A.

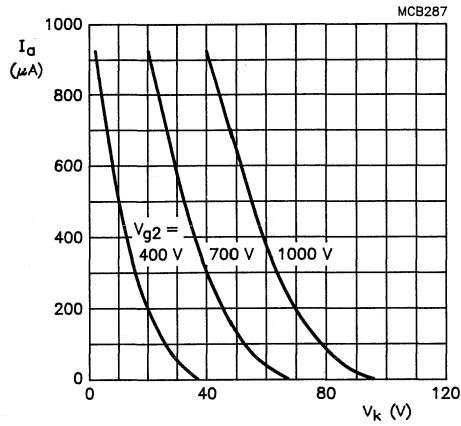

Fig. 3 Anode current as a function of cathode voltage. Cathode drive; $V_{a,g3,g5} = 14$ kV.

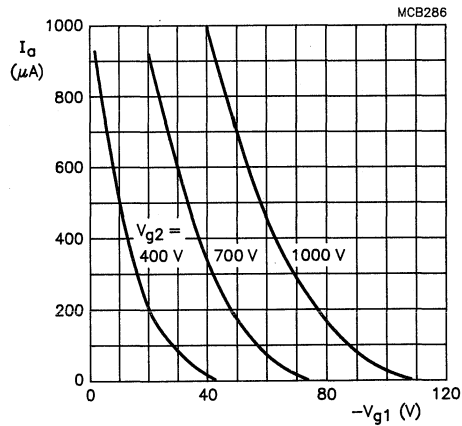

Fig. 4 Anode current as a function of grid 1 voltage. Grid drive; $V_{a,g3,g5} = 14$ kV.

DEVELOPMENT DATA

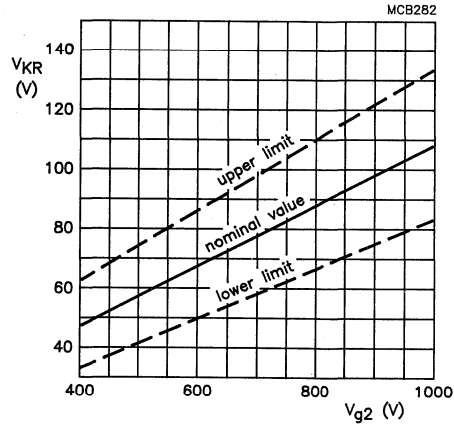

Fig. 5 Limits of cathode cut-off voltage as a function of grid 2 voltage.
Cathode drive; $V_{a,g3,g5} = 14$ kV.

$$\frac{\Delta V_{KR}}{\Delta V_{a,g3,g5}} = 0.9 \times 10^{-3}$$

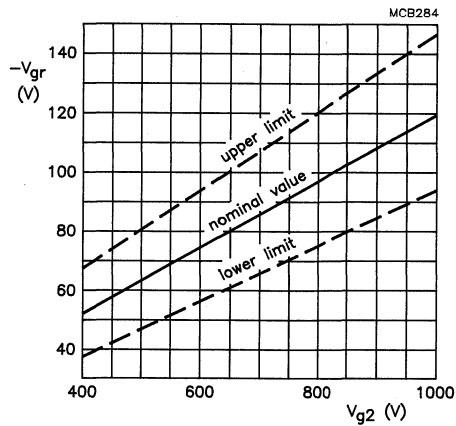
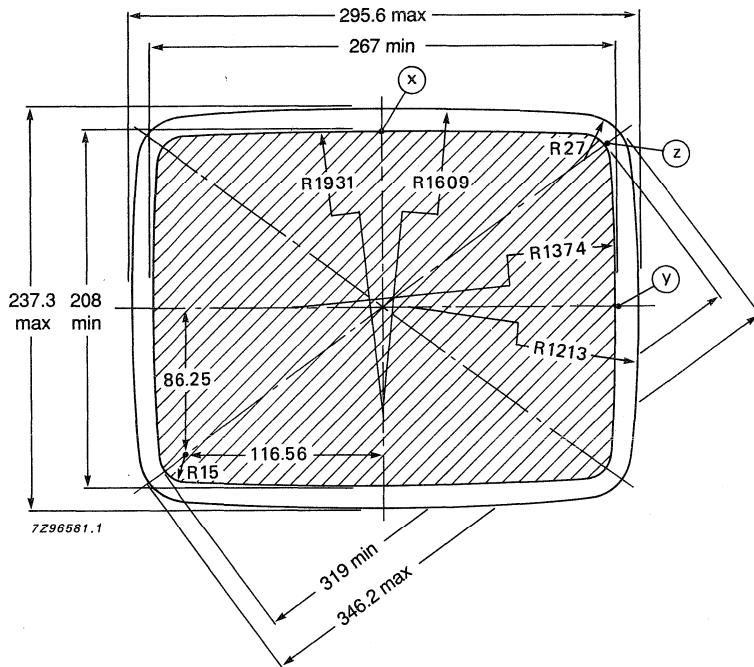
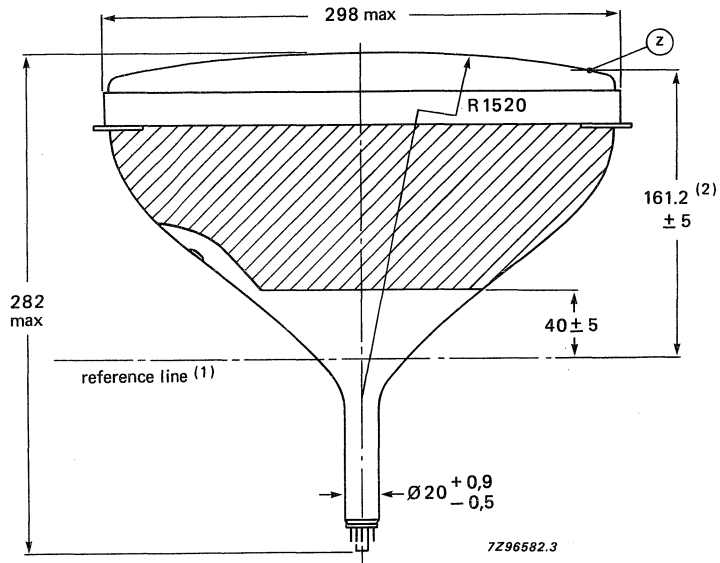

Fig. 6 Limits of grid 1 cut-off voltage as a function of grid 2 voltage.
Grid drive; $V_{a,g3,g5} = 14$ kV.

$$\frac{\Delta V_{GR}}{\Delta V_{a,g3,g5}} = 0.9 \times 10^{-3}$$

DIMENSIONAL DATA

Dimensions in mm



- (1) The reference line is determined by the plane of the upper edge of reference line gauge D when the gauge is resting on the cone.
- (2) If NEG type, this value changes to 162.9 ± 5 .

DEVELOPMENT DATA

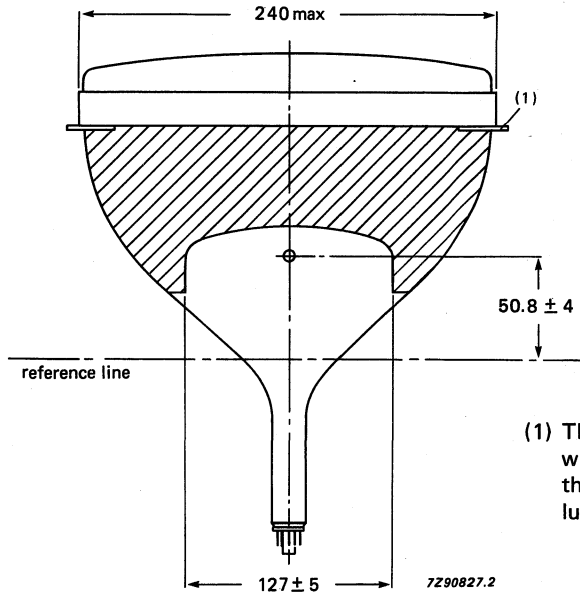

Fig. 9.

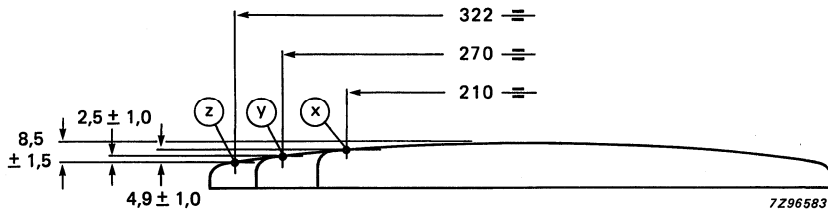

Fig. 10 Screen reference points.

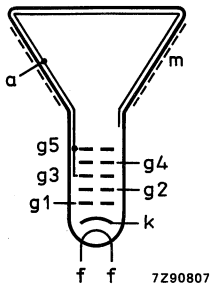

Fig. 11 Electrode configuration.

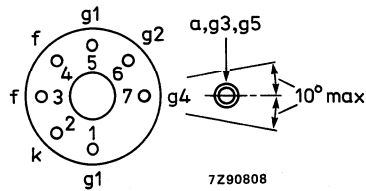

Fig. 12 Pin arrangement; bottom view.

Front view and lug dimensions

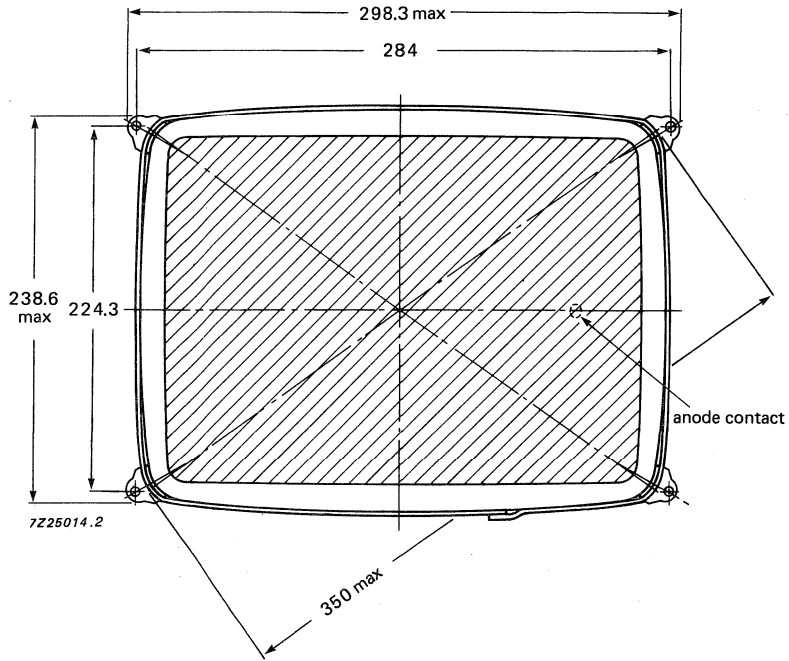

Fig. 13 Tube mounting dimensions; front view.

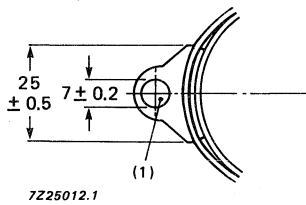

Fig. 14 Lug dimensions.

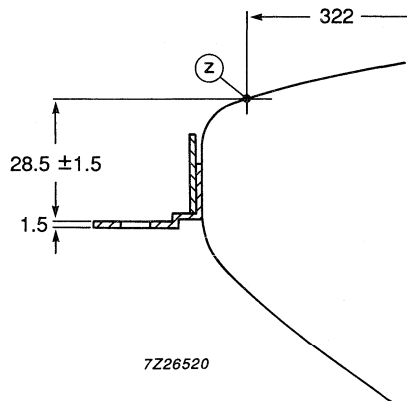

Fig. 15 Lug position.

- (1) The mounting screws in the cabinet must be situated inside a circle of 4 mm diameter drawn around the true geometrical positions i.e. at the corners of a rectangle of 284 mm x 224.3 mm.

Maximum cone contour

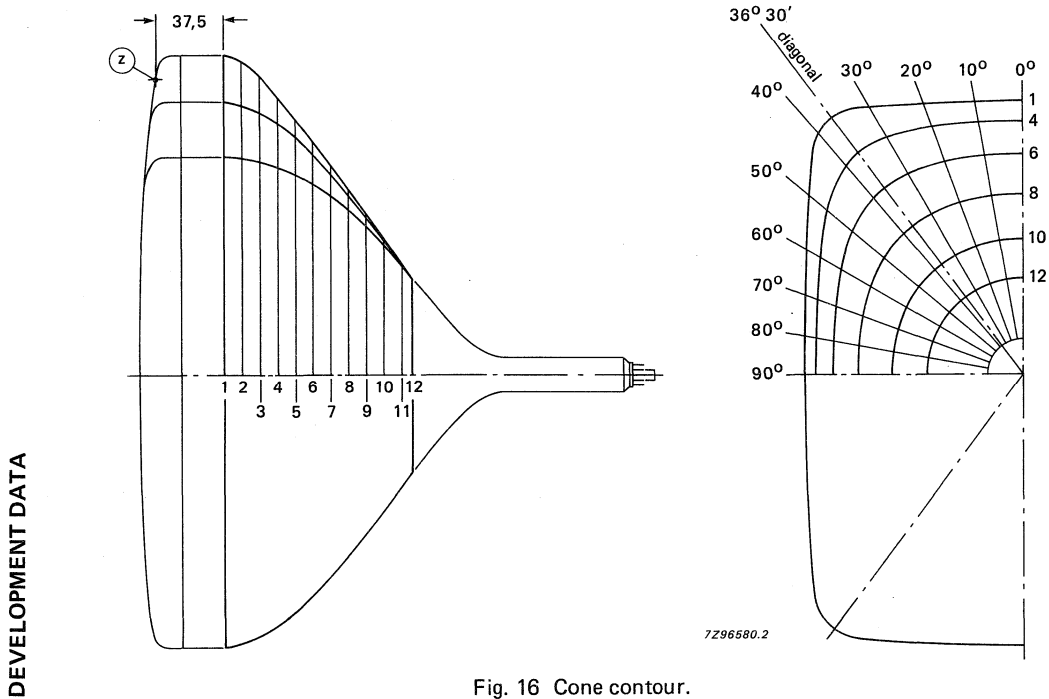

Fig. 16 Cone contour.

Table 1 Contour data

sec- tion	nom. distance from section 1	max. distance from centre										
		0,00	10,00	20,00	30,00	36,50	40,00	50,00	60,00	70,00	80,00	90,00
1	0	147,75	149,80	156,19	167,63	173,43	171,77	151,39	135,49	125,67	120,31	118,60
2	10	146,15	148,17	154,42	165,14	170,27	168,65	149,73	134,26	124,62	119,34	117,66
3	20	142,36	144,25	149,91	158,20	161,07	159,63	145,28	131,24	122,14	117,11	115,50
4	30	136,49	138,18	142,87	148,45	149,74	148,65	138,71	126,91	118,58	113,89	112,39
5	40	128,75	130,16	133,72	137,36	137,91	137,07	130,27	121,08	113,85	109,61	108,23
6	50	119,35	120,49	123,12	125,56	125,86	125,30	120,77	113,97	108,01	104,28	103,05
7	60	108,70	109,58	111,51	113,24	113,50	113,19	110,37	105,66	101,04	97,92	96,84
8	70	97,64	98,27	99,58	100,70	100,90	100,74	99,10	96,11	92,85	90,43	89,53
9	80	86,29	86,69	87,45	88,06	88,14	88,04	87,11	85,36	83,31	81,62	80,93
10	90	74,00	74,26	74,72	75,09	75,14	75,10	74,60	73,64	72,44	71,37	70,90
11	100	60,59	60,78	61,12	61,41	61,51	61,52	61,35	60,93	60,34	59,78	59,50
12	110	51,89	51,97	52,09	52,20	52,23	52,24	52,19	52,07	51,90	51,73	51,64

FLAT HIGH RESOLUTION MONOCHROME MONITOR TUBE

- For Data Graphic Displays
- 90° deflection angle
- 34 cm (14 in) face diagonal; rectangular glass
- 1520 mm radius of screen curvature
- 20 mm neck diameter
- Integral implosion protection

QUICK REFERENCE DATA

Deflection angle	90°
Face diagonal	34 cm (14 in)
Overall length	max. 282 mm
Neck diameter	20 mm
Heating	12 V/130 mA
Quick heating cathode	with a typical tube a legible picture will appear within 5 s
Grid 2 voltage	700 V
Anode voltage	14 kV
Resolution	approx. 1300 lines

APPLICATION

This high resolution tube is for alpha-numeric and graphic display applications, such as computer terminals, small business computers, etc.

AVAILABLE VERSIONS

The tube can be supplied with different phosphors and anti-reflective treatments, see "High resolution monochrome monitor tubes, General".

ELECTRICAL DATA

Focusing method	electrostatic
Deflection method	magnetic
Deflection angles	
diagonal	approx. 90°
horizontal	approx. 79°
vertical	approx. 65°
Interelectrode capacitances	
cathode to all other electrodes	max. 5 pF
grid 1 to all other electrodes	max. 7 pF
Capacitance of external conductive coating to anode*	max. 1400 pF min. 800 pF
Capacitance of external conductive coating to anode**	max. 1050 pF min. 450 pF
Capacitance of anode to implosion protection hardware**	approx. 150 pF
Heater voltage	12 V
Heater current at 12 V	130 mA

OPTICAL DATA

Phosphor type	see "High resolution mono-chrome monitor tubes, General"
Light transmission at screen centre	
tube with normal tinted face glass	approx. 42%
tube with dark tinted face glass	approx. 30%

RASTER CENTRING

The field intensity perpendicular to the tube axis should be adjustable from 0 to 800 A/m. For optimum overall sharpness it is recommended to centre the raster electrically via the deflection coils.

* Implosion protection hardware connected to external conductive coating.

** Implosion protection hardware not connected to external conductive coating.

MECHANICAL DATA (see also Figs 7 to 18)

Overall length	max. 282 mm
Greatest dimensions of tube	
diagonal	348,5 mm
width	298 mm
height	240 mm
Minimum useful screen dimensions (projected)	
diagonal	314 mm
horizontal axis	267 mm
vertical axis	208 mm
area	554 cm ²
Implosion protection	T-band/rimband
Bulb	EIAJ-JB340AH03 or EIAJ-JB340AH04
Bulb contact designation	IEC 67-III-2, EIAJ1-21
Base designation	EIA-E7-91
Basing	7GR
Mass	approx. 3,9 kg

RATINGS (Absolute Maximum System)

Unless otherwise specified voltage values are positive and measured with respect to grid 1.

Anode voltage	max. 16 kV min. 10 kV
Grid 4 (focusing electrode) voltage	-200 to + 1000 V
Grid 2 voltage	max. 1000 V min. 400 V
Anode current	
long-term average value	max. 130 μ A
peak value	max. 300 μ A
Cathode voltage, positive peak value	max. 400 V
Heater voltage	12 V +5/-10%*
Cathode-to-heater voltage	max. 100 V

* For maximum cathode life it is recommended that the heater supply be regulated at 12 V ^{+0%}/_{-5%}.

CIRCUIT DESIGN VALUES

Grid 4 current	
positive	max. 25 μ A
negative	max. 25 μ A
Grid 2 current	
positive	max. 5 μ A
negative	max. 5 μ A

MAXIMUM CIRCUIT VALUES

Resistance between cathode and heater	max. 1 M Ω
Impedance between cathode and heater	max. 0,1 M Ω
Grid 1 circuit resistance	max. 1,5 M Ω
Grid 1 circuit impedance	max. 0,5 M Ω

TYPICAL OPERATING CONDITIONS

Cathode drive; voltages specified with respect to grid 1

Anode voltage	14 kV
Grid 4 (focusing electrode) voltage	0 to 300 V*
Grid 2 voltage	700 V
Cathode cut-off voltage	57 to 97 V**

Grid drive; voltages specified with respect to cathode

Anode voltage	14 kV
Grid 4 (focusing electrode) voltage	0 to 300 V*
Grid 2 voltage	700 V
Grid 1 cut-off voltage	67 to 107 V**

RESOLUTION

The resolution is approx. 1300 lines. It is measured at the screen centre:

- with shrinking raster method,
- at light output 68,5 cd/m² (20 foot lambert) and raster dimensions 237 mm x 178 mm,
- at $V_{g2} = 700$ V and anode voltage = 14 kV,
- with phosphor type WW,
- with normal tinted face glass, without anti-glare treatment of screen surface.

X-RADIATION CHARACTERISTIC

X-radiation emitted will not exceed 0,5 mR/h throughout the useful life of the tube, when operated within the given ratings.

* Measured at screen centre on spot at anode current = 250 μ A (peak), anode voltage = 14 kV, grid 2 voltage = 700 V.

Dynamic focus (only for optimization): Typical correction for a video field of H x V = 237 mm x 178 mm:
line parabola 200 V,
field parabola 100 V.

** Visual extinction of focused raster.

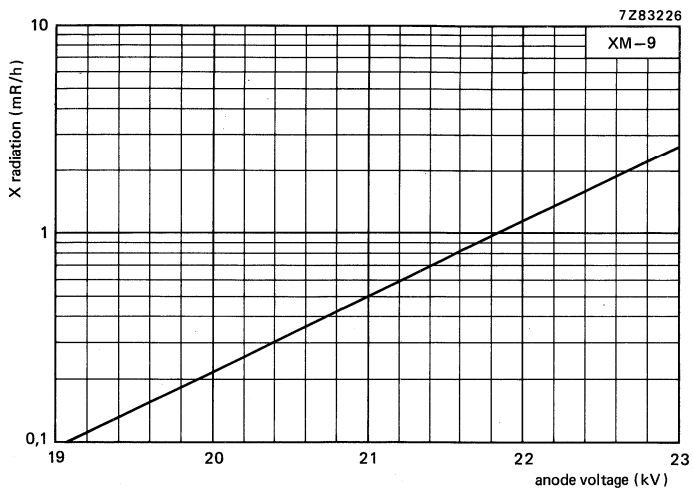

Fig.1 X-radiation limit curve according to JEDEC94, at a constant anode current of 250 μ A, measured according to TEPAC103A.

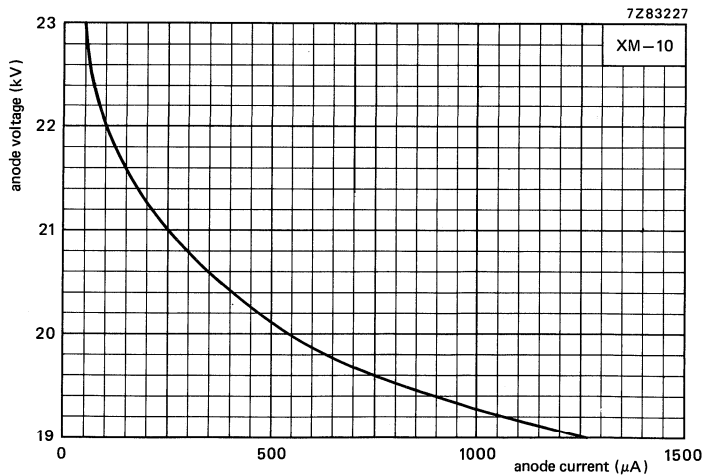

Fig.2 0,5 mR/h isoexposure-rate limit curve, according to JEDEC94, measured according to TEPAC103A.

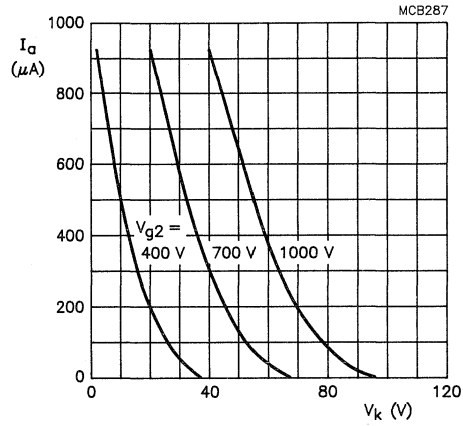

Fig.3 Anode current as a function of cathode voltage.
Cathode drive; $V_{a,g3,g5} = 14$ kV.

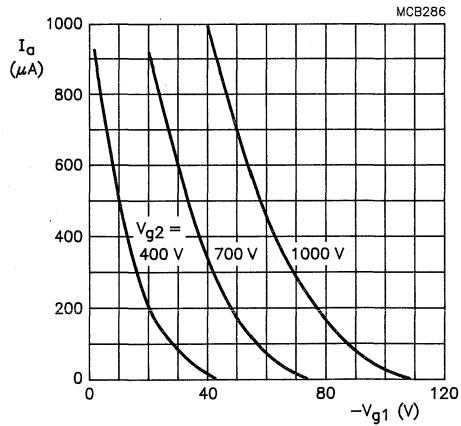

Fig.4 Anode current as a function of grid 1 voltage.
Grid drive; $V_{a,g3,g5} = 14$ kV.

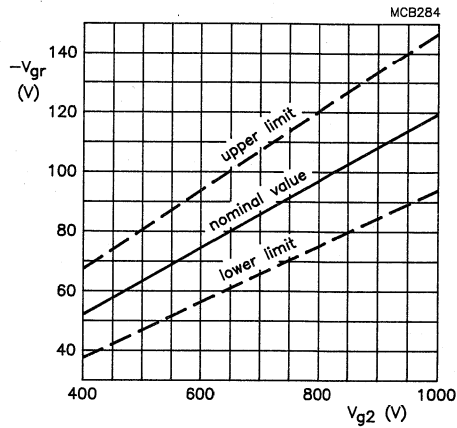

Fig.5 Limits of cathode cut-off voltage as a function of grid 2 voltage.
Cathode drive; $V_{a,g3,g5} = 14$ kV.

$$\frac{\Delta V_{KR}}{\Delta V_{a,g3,g5}} = 0.9 \times 10^{-3}.$$

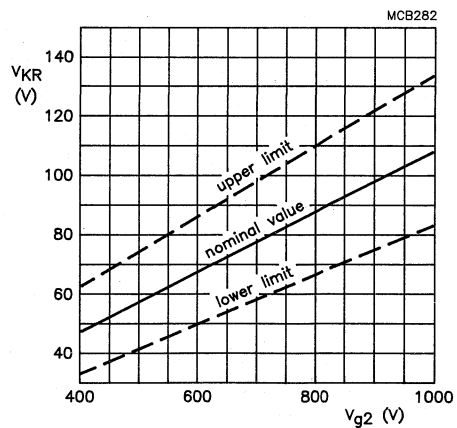

Fig.6 Limits of grid 1 cut-off voltage as a function of grid 2 voltage.
Grid drive; $V_{a,g3,g5} = 14$ kV.

$$\frac{\Delta V_{GR}}{\Delta V_{a,g3,g5}} = 0.9 \times 10^{-3}.$$

DIMENSIONAL DATA

Dimensions in mm

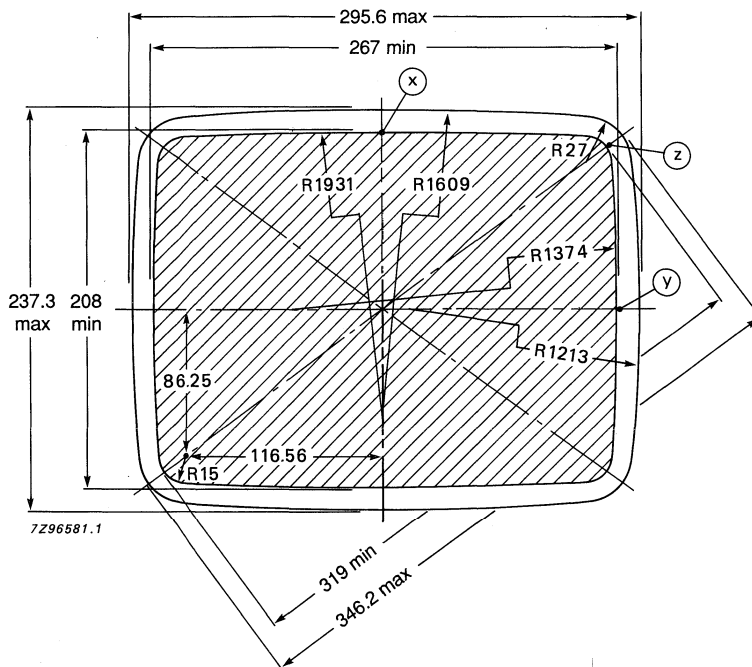
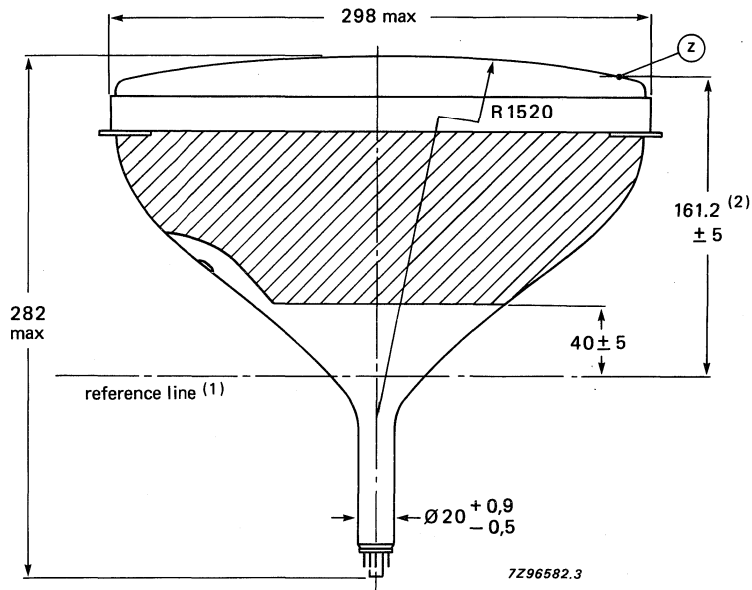

Fig. 8.

- (1) The reference line is determined by the plane of the upper edge of reference line gauge D when the gauge is resting on the cone.
- (2) If NEG type, this value changes to 162.9 ± 5 .

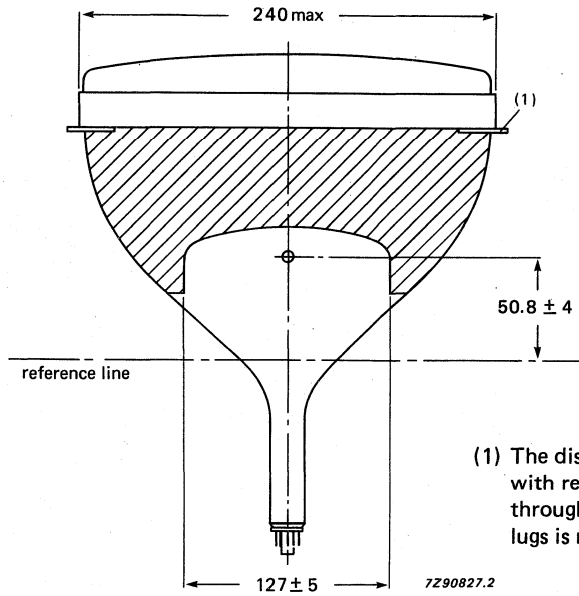

Fig.9.

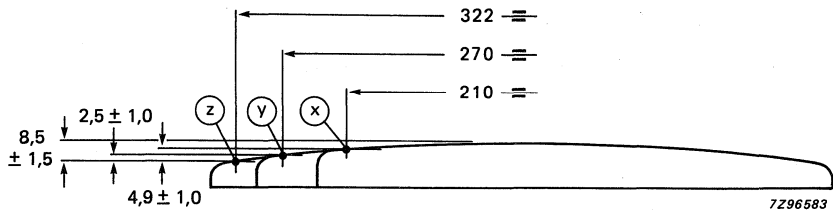

Fig.10 Screen reference points.

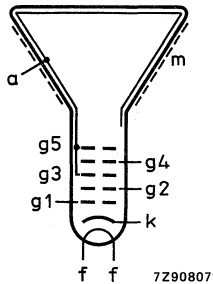

Fig.11 Electrode configuration.

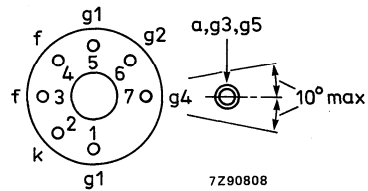

Fig.12 Pin arrangement.

Front view and lug dimensions of tube M32ECB

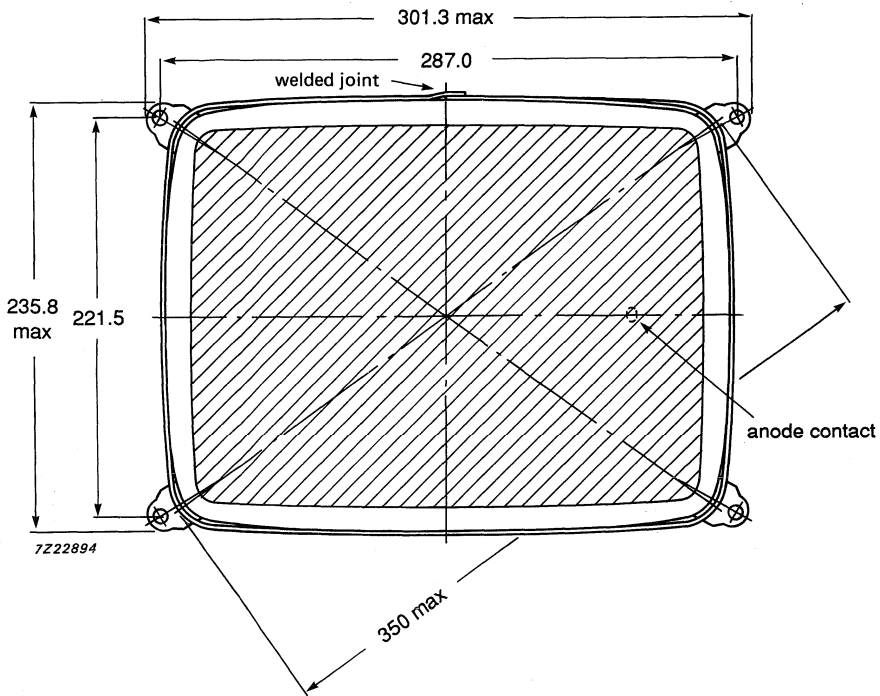

Fig.15 Tube mounting dimensions; front view.

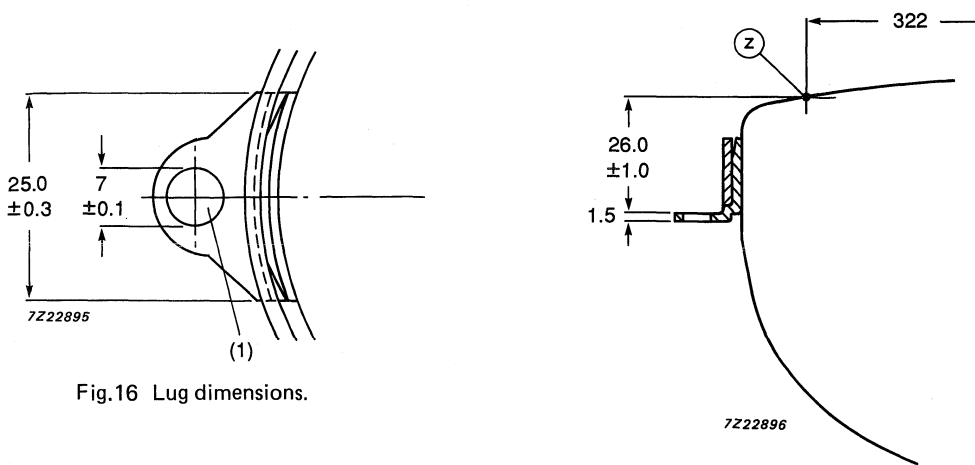

Fig.16 Lug dimensions.

Fig.17 Lug position.

(1) The mounting screws in the cabinet must be situated inside a circle of 4 mm diameter drawn around the true geometrical positions i.e. at the corners of a rectangle of 287,0 mm x 221,5 mm.

Maximum cone contour

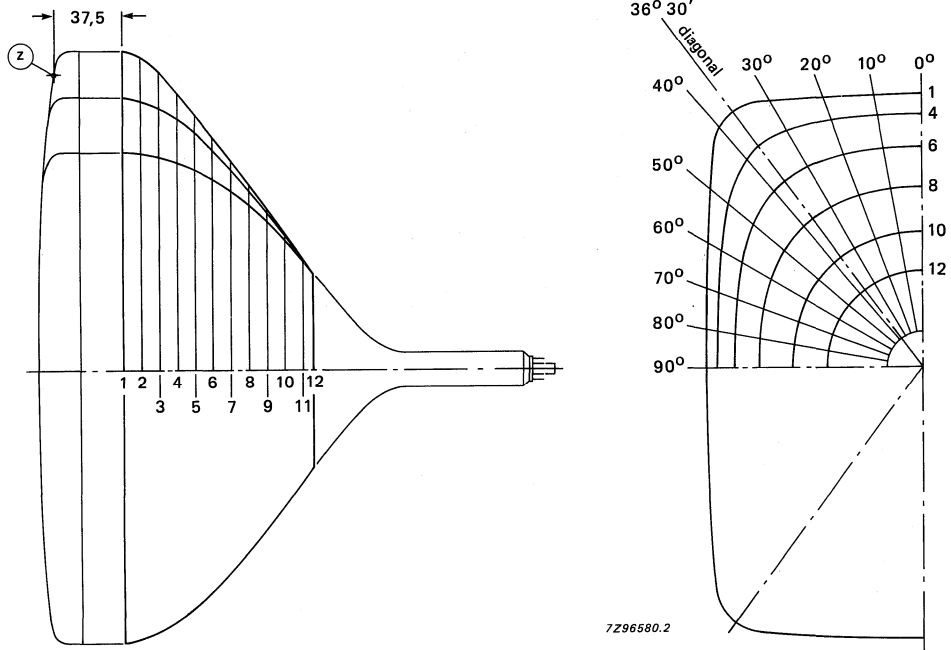

Fig.18 Cone contour.

sec- tion	nom. distance from section 1	max. distance from centre										
		0,00	10,00	20,00	30,00	36,50	40,00	50,00	60,00	70,00	80,00	90,00
1	0	147,75	149,80	156,19	167,63	173,43	171,77	151,39	135,49	125,67	120,31	118,60
2	10	146,15	148,17	154,42	165,14	170,27	168,65	149,73	134,26	124,62	119,34	117,66
3	20	142,36	144,25	149,91	158,20	161,07	159,63	145,28	131,24	122,14	117,11	115,50
4	30	136,49	138,18	142,87	148,45	149,74	148,65	138,71	126,91	118,58	113,89	112,39
5	40	128,75	130,16	133,72	137,36	137,91	137,07	130,27	121,08	113,85	109,61	108,23
6	50	119,35	120,49	123,12	125,56	125,86	125,30	120,77	113,97	108,01	104,28	103,05
7	60	108,70	109,58	111,51	113,24	113,50	113,19	110,37	105,66	101,04	97,92	96,84
8	70	97,64	98,27	99,58	100,70	100,90	100,74	99,10	96,11	92,85	90,43	89,53
9	80	86,29	86,69	87,45	88,06	88,14	88,04	87,11	85,36	83,31	81,62	80,93
10	90	74,00	74,26	74,72	75,09	75,14	75,10	74,60	73,64	72,44	71,37	70,90
11	100	60,59	60,78	61,12	61,41	61,51	61,52	61,35	60,93	60,34	59,78	59,50
12	110	51,89	51,97	52,09	52,20	52,23	52,24	52,19	52,07	51,90	51,73	51,64

DEVELOPMENT DATA

This data sheet contains advance information and specifications are subject to change without notice.

M36EAB
M36ECJ

FLAT SQUARE HIGH RESOLUTION MONOCHROME MONITOR TUBE

- For Data Graphic Displays
- 110° deflection angle
- 38 cm (15 in) face diagonal; rectangular glass
- 1200 mm radius of screen curvature
- 28.6 mm neck diameter
- Integral implosion protection

QUICK REFERENCE DATA

Deflection angle	110°
Face diagonal	38 cm (15 in)
Overall length	max. 287 mm
Neck diameter	28.6 mm
Heating	6.3 V/240 mA
Quick heating cathode	with a typical tube a legible picture will appear within 5 s
Grid 2 voltage	700 V
Anode voltage	17 kV
Resolution	approx. 1500 lines

APPLICATION

This high resolution tube is for alpha-numeric and graphic display applications, such as computer terminals, small business computers, etc.

AVAILABLE VERSIONS

The tube can be supplied with different phosphors and anti-reflective treatments, see "High resolution monochrome monitor tubes, General".

ELECTRICAL DATA

Focusing method	electrostatic
Deflection method	magnetic
Deflection angles	
diagonal	approx. 110°
horizontal	approx. 97°
vertical	approx. 80°
Interelectrode capacitances	
cathode to all other electrodes	max. 5 pF
grid 1 to all other electrodes	max. 9 pF
Capacitance of external conductive coating to anode*	max. 1200 pF min. 600 pF
Heater voltage	6,3 V
Heater current at 6,3 V	240 mA

OPTICAL DATA

Phosphor type	see "High resolution monochrome monitor tubes, General"
Light transmission at screen centre	approx. 34%

RASTER CENTRING

The field intensity perpendicular to the tube axis should be adjustable from 0 to 800 A/m. For optimum overall sharpness it is recommended to centre the raster electrically via the deflection coils.

* Implosion protection hardware connected to external conductive coating.

MECHANICAL DATA (see also the figures under Dimensional Data)

Overall length	max. 287 mm
Greatest dimensions of tube	
diagonal	396 mm
width	332 mm
height	267 mm
Minimum useful screen dimensions (projected)	
diagonal	363 mm
horizontal axis	296 mm
vertical axis	229 mm
area	670 cm ²
Implosion protection	rimband
Bulb	EIAJ-JB390AA03
Bulb contact designation	IEC 67-III-2, EIAJ1-21
Base designation	EIA-B7-208; IEC 67-1-31a
Basing	8HR
Mass	approx. 5,8 kg

DEVELOPMENT DATA

RATINGS (Absolute Maximum System)

Unless otherwise specified voltage values are positive and measured with respect to grid 1.

Anode voltage	max. 19 kV min. 13 kV
Grid 4 (focusing electrode) voltage	-200 to + 1000 V
Grid 2 voltage	max. 1000 V min. 400 V
Anode current	
long-term average value	max. 100 μ A
peak value	max. 300 μ A
Cathode voltage, positive peak value	max. 400 V
Heater voltage	6.3 V + 5/-10%*
Cathode-to-heater voltage	max. 100 V

* For maximum cathode life it is recommended that the heater supply be regulated at 6,3 V $\begin{matrix} +0\% \\ -5\% \end{matrix}$

CIRCUIT DESIGN VALUES

Grid 4 current	
positive	max. 25 μ A
negative	max. 25 μ A
Grid 2 current	
positive	max. 5 μ A
negative	max. 5 μ A

MAXIMUM CIRCUIT VALUES

Resistance between cathode and heater	max. 1.0 M Ω
Impedance between cathode and heater	max. 0.1 M Ω
Grid 1 circuit resistance	max. 1.5 M Ω
Grid 1 circuit impedance	max. 0.5 M Ω

TYPICAL OPERATING CONDITIONS

Cathode drive; voltages specified with respect to grid 1

Anode voltage	17 kV
Grid 4 (focusing electrode) voltage	0 to 400 V*
Grid 2 voltage	700 V
Cathode cut-off voltage	72 to 112 V**

Grid drive; voltages specified with respect to cathode

Anode voltage	17 kV
Grid 4 (focusing electrode) voltage	0 to 400 V*
Grid 2 voltage	700 V
Grid 1 cut-off voltage	84 to 126 V**

RESOLUTION

The resolution is approx. 1500 lines. It is measured at the screen centre:

- with shrinking raster method,
- at light output 68,5 cd/m² (20 foot lambert) and raster dimensions 267 mm x 200 mm,
- at $V_{g2} = 700$ V and anode voltage = 17 kV,
- with phosphor type W (WW),
- without anti-glare treatment of screen surface.

X-RADIATION CHARACTERISTIC

X-radiation emitted will not exceed 0,5 mR/h throughout the useful life of the tube, when operated within the given ratings.

* Measured at screen centre on spot at anode current = 250 μ A (peak), anode voltage = 17 kV, grid 2 voltage = 700 V.

Dynamic focus (only for optimization):

typical correction for a video field of H x V = 267 mm x 200 mm (landscape format):

line parabola 350 V, field parabola 100 V;

typical correction for a video field of H x V = 200 mm x 267 mm (portrait format):

line parabola 200 V, field parabola 250 V.

** Visual extinction of focused raster.

DEVELOPMENT DATA

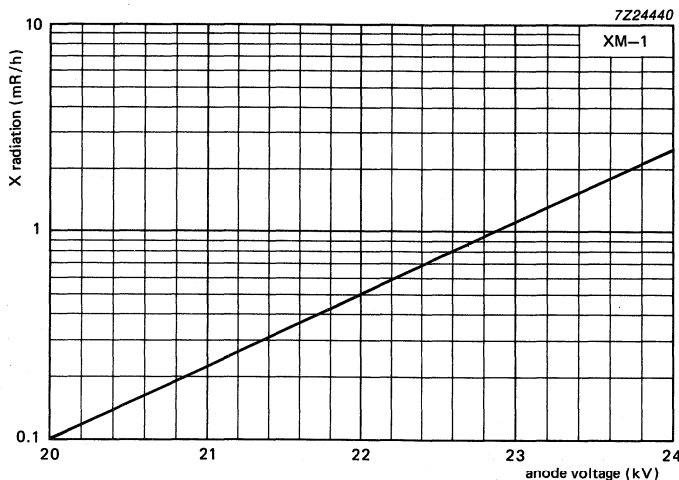

Fig. 1 X-radiation limit curve according to JEDEC 94, at a constant anode current of 250 μ A, measured according to TEPAC103A.

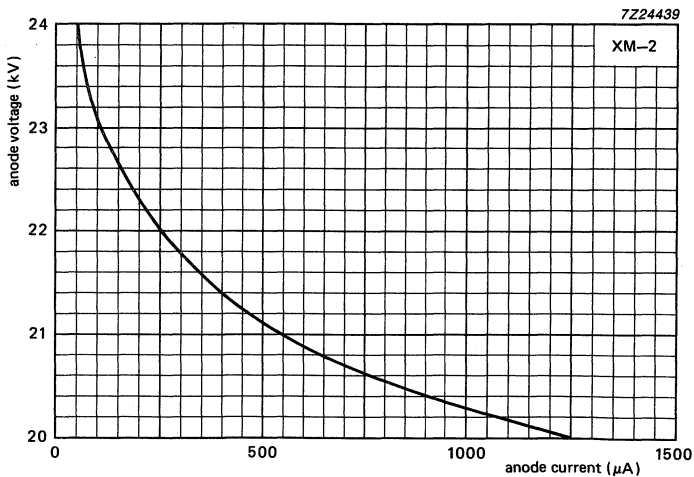

Fig. 2 0.5 mR/h isoexposure-rate limit curve, according to JEDEC 94, measured according to TEPAC103A.

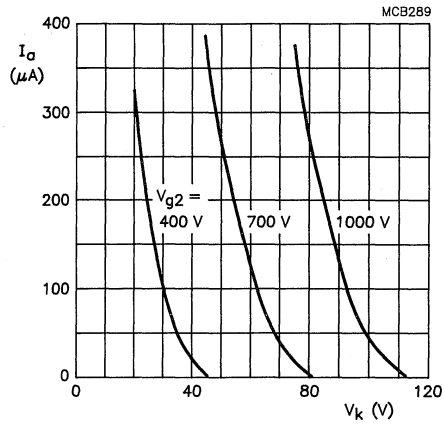

Fig. 3 Anode current as a function of cathode voltage.
Cathode drive; $V_{a,g3,g5} = 17$ kV.

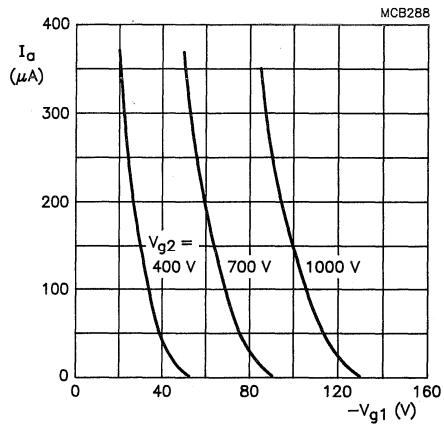

Fig. 4 Anode current as a function of grid 1 voltage.
Grid drive; $V_{a,g3,g5} = 17$ kV.

DEVELOPMENT DATA

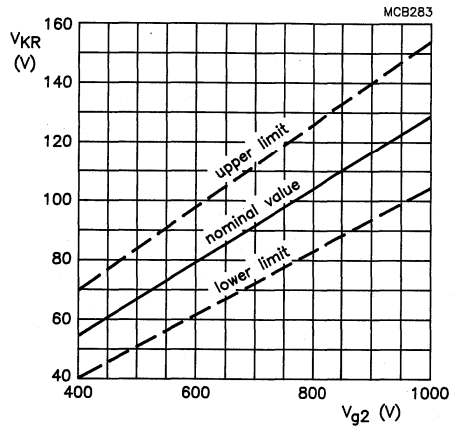

Fig. 5 Limits of cathode raster cut-off voltage as a function of grid 2 voltage.
Cathode drive; $V_{a,g3,g5} = 17$ kV.

$$\frac{\Delta V_{KR}}{\Delta V_{a,g3,g5}} = 0.15 \times 10^{-3}$$

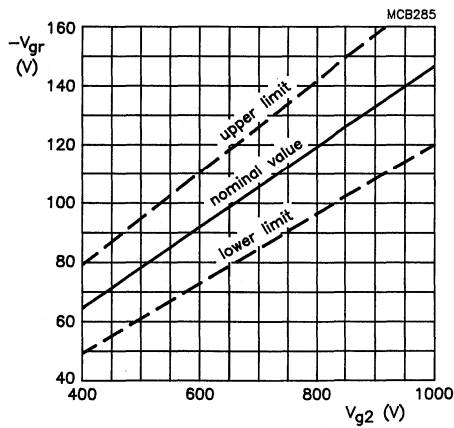

Fig. 6 Limits of grid 1 raster cut-off voltage as a function of grid 2 voltage.
Grid drive; $V_{a,g3,g5} = 17$ kV.

$$\frac{\Delta V_{GR}}{\Delta V_{a,g3,g5}} = 0.15 \times 10^{-3}$$

DIMENSIONAL DATA

Dimensions in mm

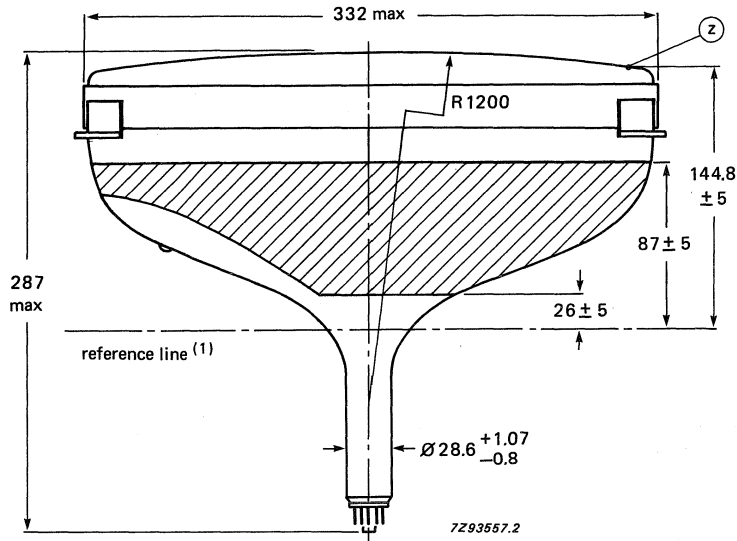

Fig. 7.

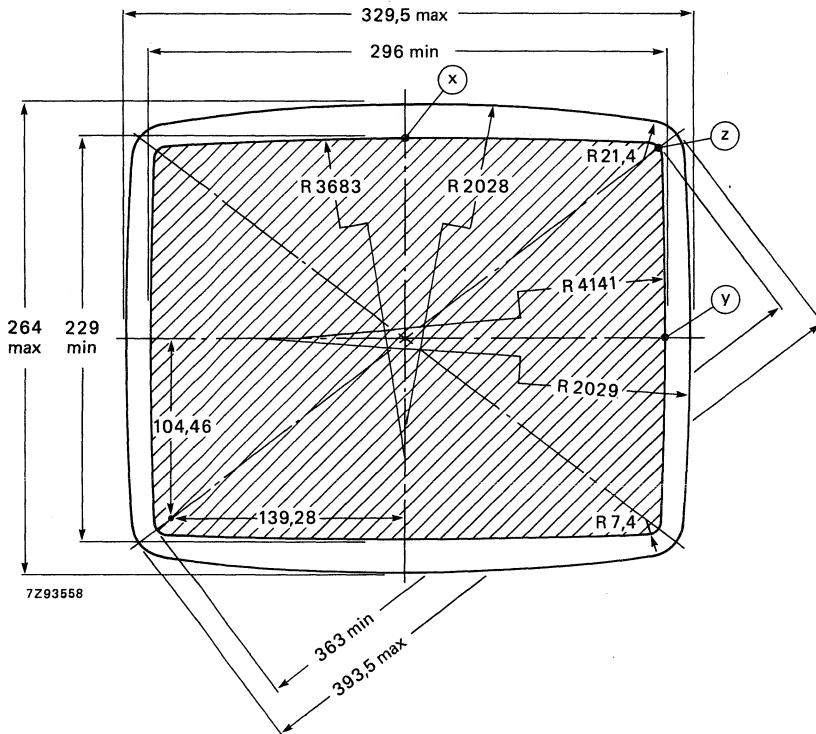

Fig. 8.

(1) The reference line is determined by the plane of the upper edge of reference line gauge C when the gauge is resting on the cone.

DEVELOPMENT DATA

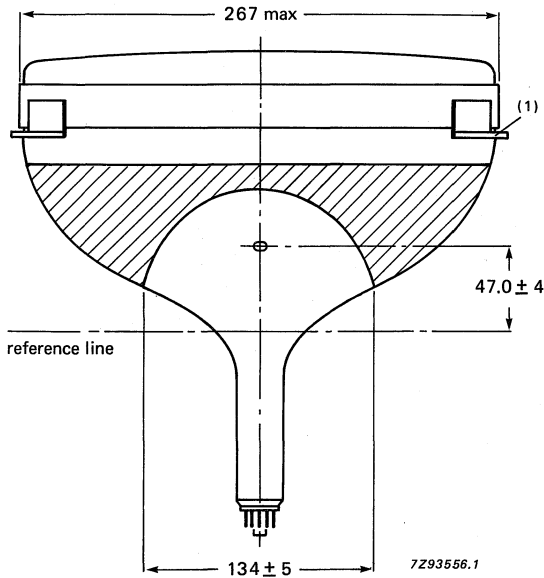

Fig. 9.

(1) The displacement of any lug with respect to the plane through the other three lugs is max. 1.5 mm.

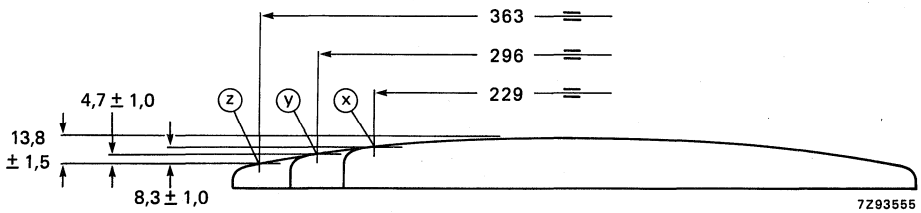

Fig. 10 Screen reference points.

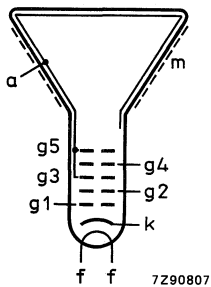

Fig. 11 Electrode configuration.

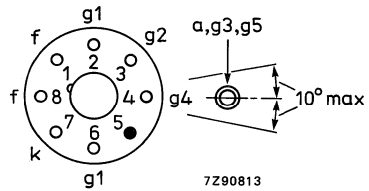

Fig. 12 Pin arrangement; bottom view.

Front view and lug dimensions of tube M36ECJ

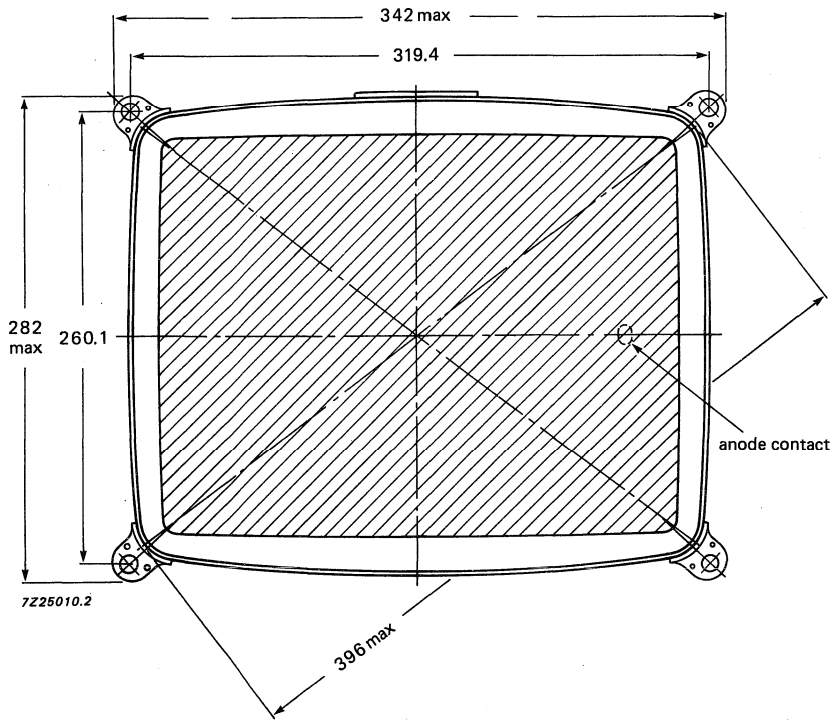

Fig. 13 Tube mounting dimensions; front view.

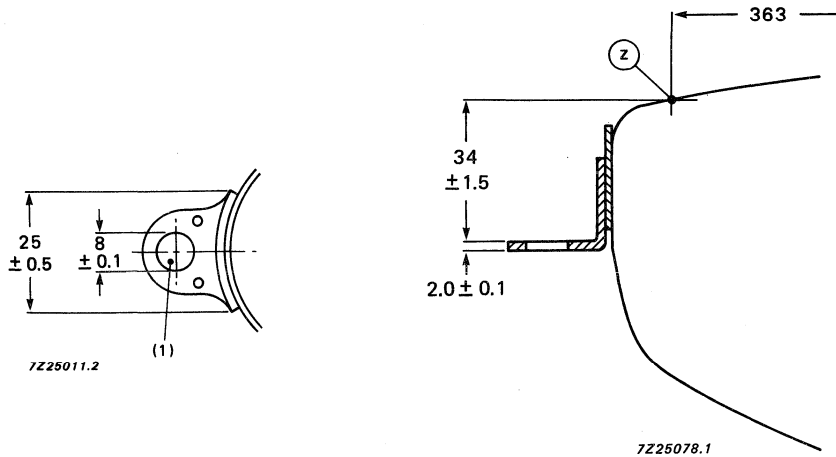

Fig. 14 Lug dimensions.

Fig. 15 Lug position.

(1) The mounting screws in the cabinet must be situated inside a circle of 5 mm diameter drawn around the true geometrical positions i.e. at the corners of a rectangle of 319.4 mm x 260.1 mm.

Front view and lug dimensions of tube M36EAB

DEVELOPMENT DATA

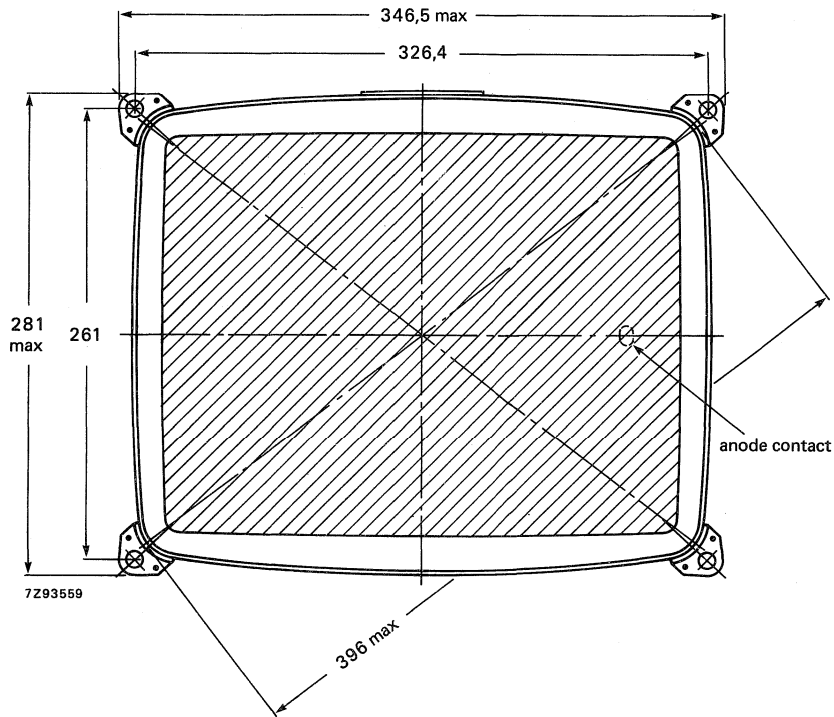

Fig. 16 Tube mounting dimensions; front view.

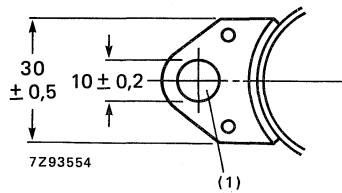

Fig. 17 Lug dimensions.

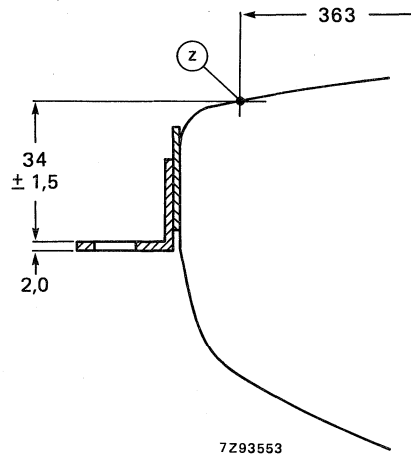

Fig. 18 Lug position.

(1) The mounting screws in the cabinet must be situated inside a circle of 7 mm diameter drawn around the true geometrical positions i.e. at the corners of a rectangle of 326.4 mm x 261 mm.

Maximum cone contour

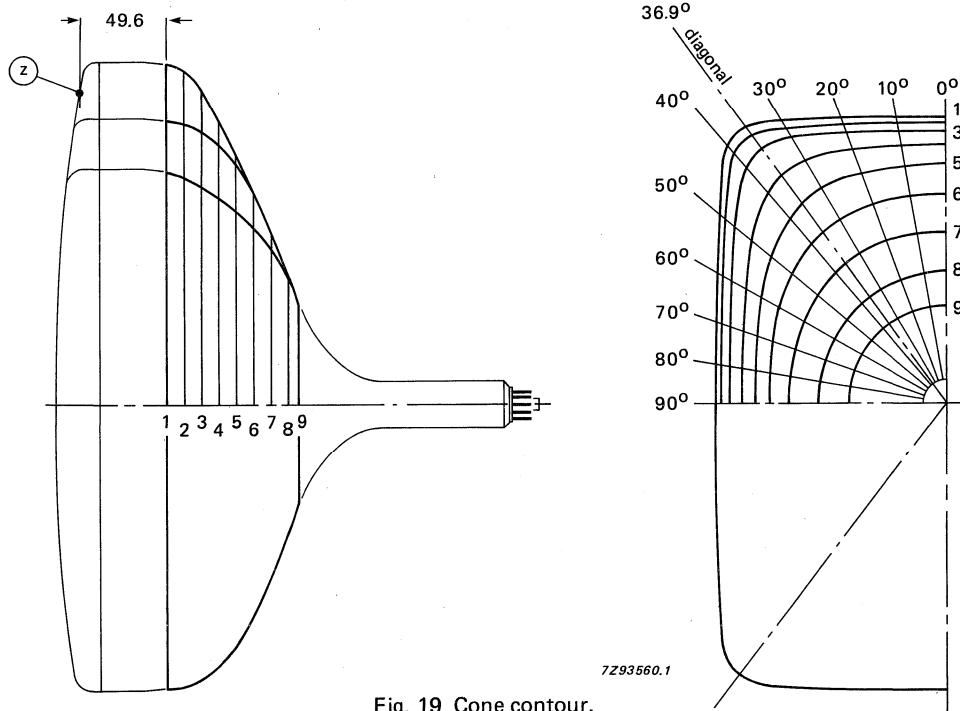

Fig. 19 Cone contour.

Table 1 Contour data

sec- tion	nom. distance from section 1	max. distance from centre										
		0°	10°	20°	30°	diag.	40°	50°	60°	70°	80°	90°
1	0	164,4	166,7	174,0	187,2	196,5	194,1	168,0	150,4	139,5	133,6	131,7
2	10	162,5	164,8	171,9	184,8	193,4	190,6	165,2	147,9	137,2	131,3	129,5
3	20	157,6	159,7	166,3	177,4	182,4	179,2	157,5	141,4	131,4	125,8	124,1
4	30	149,7	151,5	156,5	162,6	162,6	160,2	145,9	132,6	123,8	118,9	117,4
5	40	138,1	139,3	141,8	143,0	141,4	139,8	131,7	122,7	115,7	111,6	110,2
6	50	121,0	121,4	121,9	121,4	120,0	119,1	115,1	110,3	105,9	102,9	101,8
7	60	99,2	99,3	99,4	99,0	98,4	98,1	96,6	94,7	92,7	91,2	90,5
8	70	76,2	76,2	76,2	76,0	75,9	75,8	75,5	75,2	74,7	74,4	74,2
9	75, 39	57,8	57,8	57,8	57,8	57,8	57,8	57,8	57,8	57,8	57,8	57,8

HIGH RESOLUTION MONOCHROME MONITOR TUBES

- For Data Graphic Displays
- 110° deflection angle
- 38 cm (15 in) face diagonal; rectangular glass
- 28,6 mm neck diameter
- Integral implosion protection

QUICK REFERENCE DATA

Deflection angle	110°
Face diagonal	38 cm (15 in)
Overall length	max. 290 mm
Neck diameter	28,6 mm
Heating	6,3 V/240 mA
Quick heating cathode	with a typical tube a legible picture will appear within 5 s
Grid 2 voltage	700 V
Anode voltage	17 kV
Resolution	approx. 1500 lines

APPLICATION

These high resolution tubes are for alphanumeric and graphic display applications, such as computer terminals, small business computers, etc.

AVAILABLE VERSIONS

The following versions are available: M38-328, M38-330, M38-334, M38-336, M38-338 and M38-342.

Differences between the tubes can be found under 'Dimensional data'.

The tubes can be supplied with different phosphors and anti-reflective treatments, see 'High resolution monochrome monitor tubes, General'.

ELECTRICAL DATA

Focusing method	electrostatic
Deflection method	magnetic
Deflection angles	
diagonal	approx. 110°
horizontal	approx. 98°
vertical	approx. 81°
Direct interelectrode capacitances	
cathode to all other electrodes	max. 5 pF
grid 1 to all other electrodes	max. 9 pF
Capacitance of external conductive coating to anode*	max. 1200 pF min. 600 pF
Capacitance of external conductive coating to anode**	max. 1000 pF min. 500 pF
Capacitance of anode to implosion protection hardware**	approx. 200 pF
Heater voltage	6,3 V
Heater current at 6,3 V	240 mA

OPTICAL DATA

Phosphor type	see "High resolution monochrome monitor tubes, General"
Light transmission at screen centre	
tube with normal tinted face glass	approx. 46%
tube with dark tinted face glass	approx. 34%

RASTER CENTRING

The field intensity perpendicular to the tube axis should be adjustable from 0 to 800 A/m. For optimum overall sharpness it is recommended to centre the raster electrically via the deflection coils.

* Implosion protection hardware connected to external conductive coating.

** Implosion protection hardware not connected to external conductive coating.

MECHANICAL DATA (see also the figures under Dimensional Data)

Overall length	max. 290 mm
Greatest dimensions of tube	
diagonal	383 mm
width	324 mm
height	262 mm
Minimum useful screen dimensions (projected)	
diagonal	352 mm
horizontal axis	292 mm
vertical axis	277 mm
area	652 cm ²
Implosion protection	rimband
Bulb	EIAJ-JB370AB03 or EIAJ-JB370AB04
Bulb contact designation	IEC 67-III-2; EIA-J1-21
Base designation	IEC 67-1-31a; EIA-B7-208
Basing	8 HR
Mass	approx. 4 kg

RATINGS (Absolute Maximum System)

Unless otherwise specified voltage values are positive and measured with respect to grid 1.

Anode voltage	max. 19 kV min. 13 kV
Grid 4 (focusing electrode) voltage	-200 to +1000 V
Grid 2 voltage	max. 1000 V min. 400 V
Anode current	
long-term average value	max. 100 μ A
peak value	max. 300 μ A
Cathode voltage, positive peak value	max. 400 V
Heater voltage	6,3 V +5/-10%*
Cathode-to-heater voltage	max. 100 V

* For maximum cathode life it is recommended that the heater supply be regulated at 6,3 V $\begin{matrix} +0\% \\ -5\% \end{matrix}$.

CIRCUIT DESIGN VALUES

Grid 4 current		
positive	max.	25 μ A
negative	max.	25 μ A
Grid 2 current		
positive	max.	5 μ A
negative	max.	5 μ A

MAXIMUM CIRCUIT VALUES

Resistance between cathode and heater	max.	1.0 M Ω
Impedance between cathode and heater	max.	0.1 M Ω
Grid 1 circuit resistance	max.	1.5 M Ω
Grid 1 circuit impedance	max.	0.5 M Ω

TYPICAL OPERATING CONDITIONS

Cathode drive; voltages specified with respect to grid 1

Anode voltage	17 kV
Grid 4 (focusing electrode) voltage	0 to 400 V*
Grid 2 voltage	700 V
Cathode cut-off voltage	72 to 112 V**

Grid drive; voltages specified with respect to cathode

Anode voltage	17 kV
Grid 4 (focusing electrode) voltage	0 to 400 V*
Grid 2 voltage	700 V
Grid 1 cut-off voltage	84 to 126 V**

RESOLUTION

The resolution is approx. 1500 lines. It is measured at the screen centre:

- with shrinking raster method,
- at light output 68,5 cd/m² (20 foot lambert) and raster dimensions 254 mm x 194 mm,
- at $V_{g2} = 700$ V and anode voltage = 17 kV,
- with phosphor type W (WW),
- with normal tinted face glass, without anti-glare treatment of screen surface.

X-RADIATION CHARACTERISTIC

X-radiation emitted will not exceed 0,5 mR/h throughout the useful life of the tube, when operated within the given ratings.

* Measured at screen centre on spot at anode current = 250 μ A (peak), anode voltage = 17 kV, grid 2 voltage = 700 V.

Dynamic focus (only for optimization): Typical correction for a video field of
 H x V = 259 mm x 194 mm (landscape format): line parabola 300 V, field parabola 100 V;
 H x V = 194 mm x 259 mm (portrait format): line parabola 200 V, field parabola 250 V.

** Visual extinction of focused raster.

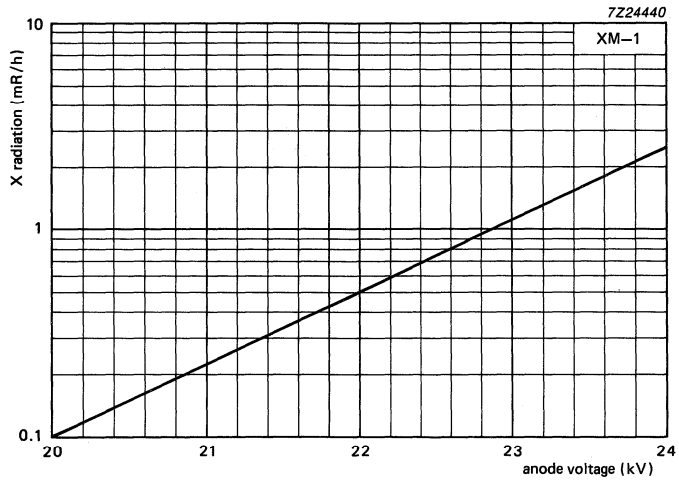

Fig. 1 X-radiation limit curve according to JEDEC 94, at a constant anode current of 250 μ A, measured according to TEPAC103A.

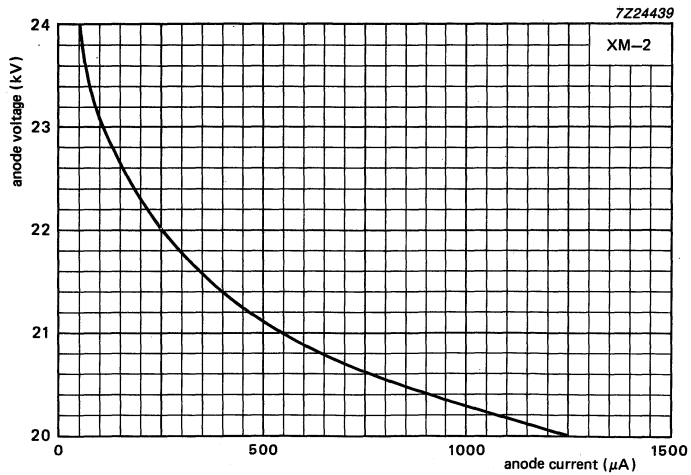

Fig. 2 0,5 mR/h isoexposure rate limit curve, according to JEDEC 94, measured according to TEPAC103A.

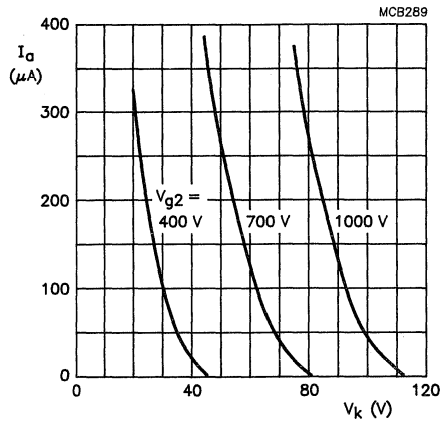

Fig. 3 Anode current as a function of cathode voltage.
Cathode drive; $V_{a,g3,g5} = 17 \text{ kV}$.

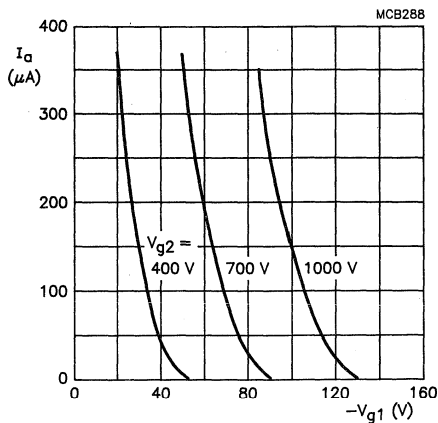

Fig. 4 Anode current as a function of grid 1 voltage.
Grid drive; $V_{a,g3,g5} = 17 \text{ kV}$.

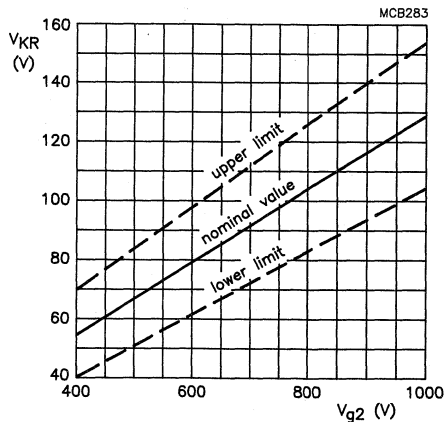

Fig. 5 Limits of cathode cut-off voltage as a function of grid 2 voltage.
 Cathode drive; $V_{a,g3,g5} = 17$ kV.

$$\frac{\Delta V_{KR}}{\Delta V_{a,g3,g5}} = 0,15 \times 10^{-3}$$

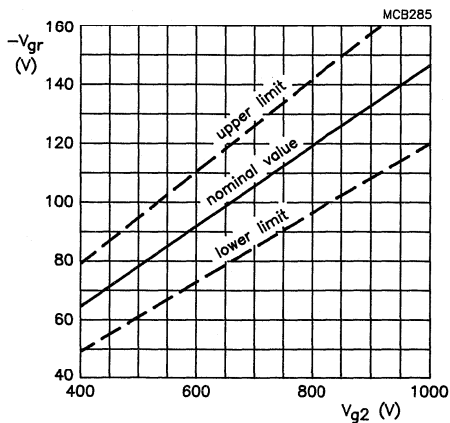

Fig. 6 Limits of grid 1 cut-off voltage as a function of grid 2 voltage.
 Grid drive; $V_{a,g3,g5} = 17$ kV.

$$\frac{\Delta V_{GR}}{\Delta V_{a,g3,g5}} = 0,15 \times 10^{-3}$$

DIMENSIONAL DATA

Dimensions in mm

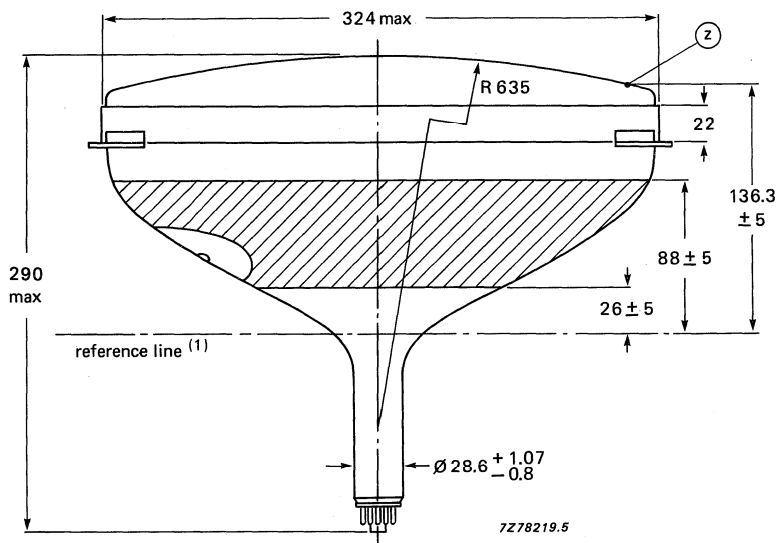

Fig. 7

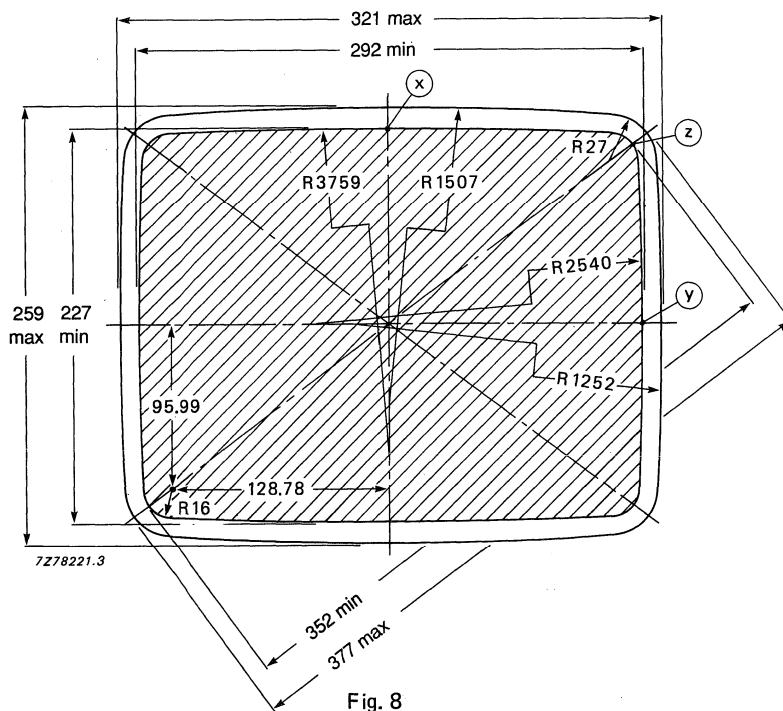

Fig. 8

(1) The reference line is determined by the plane of the upper edge of reference line gauge C when the gauge is resting on the cone.

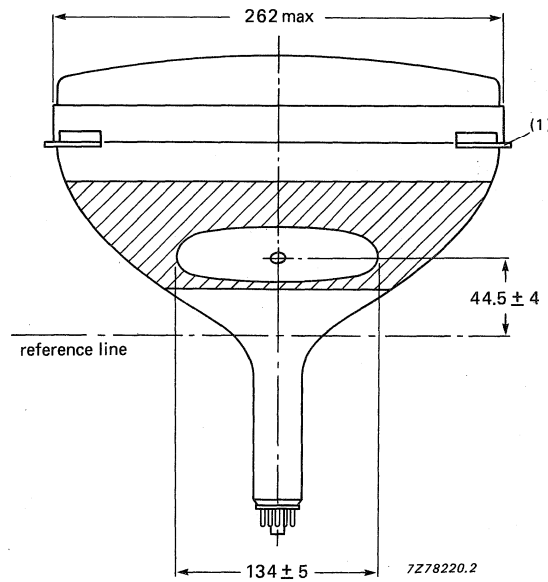

Fig. 9

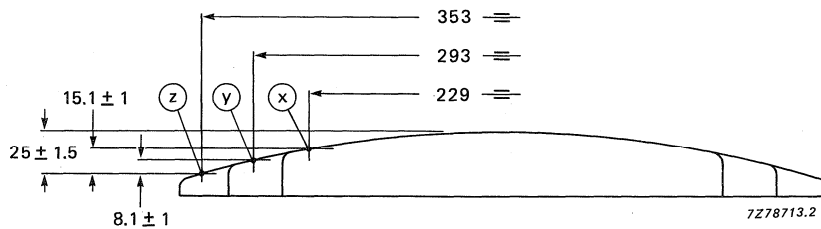

Fig. 10 Screen reference points.

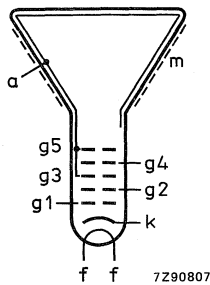

Fig. 11 Electrode configuration.

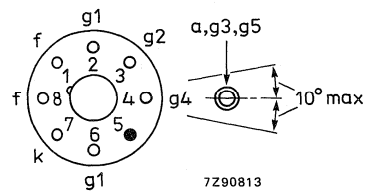

Fig. 12 Pin arrangement.

(1) The displacement of any lug with respect to the plane through the three other lugs is max. 1.5 mm.

M38-328 M38-330
M38-334 M38-336
M38-338 M38-342

Front view and lug dimensions of tube M38-328

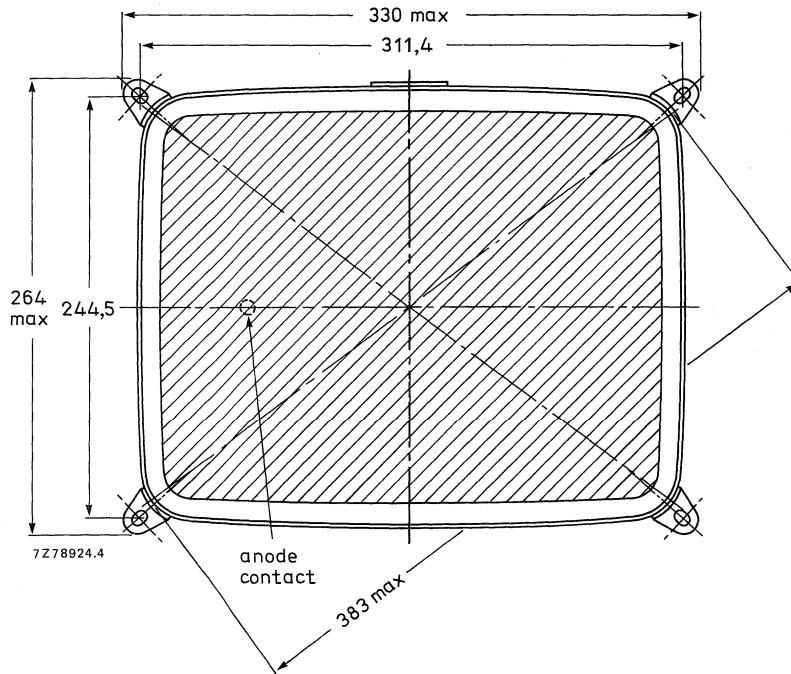

Fig. 13 Tube mounting dimensions; front view.

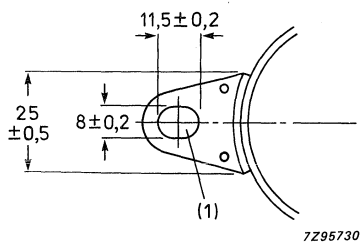

Fig. 14 Lug dimensions.

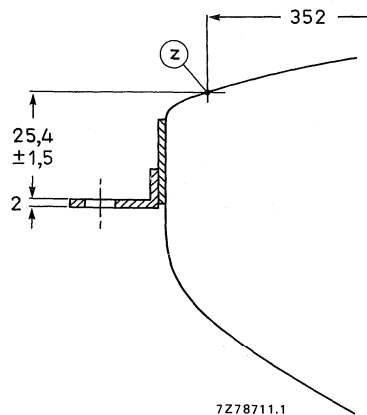

Fig. 15 Lug position.

(1) The mounting screws in the cabinet must be situated inside a circle of 5 mm diameter drawn around the true geometrical positions i.e. at the corners of a rectangle of 311.4 mm x 244.5 mm.

Front view and lug dimensions of tube M38-330

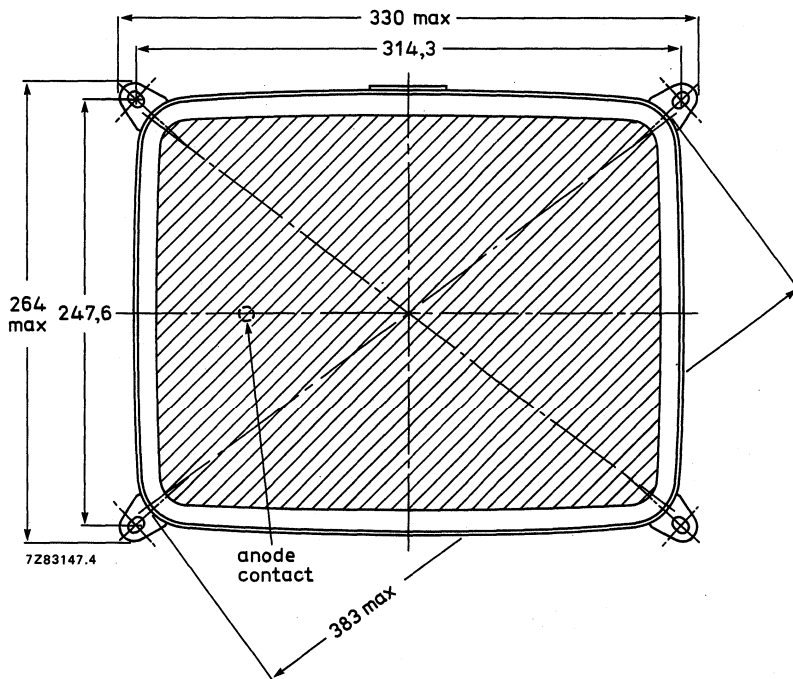

Fig. 16 Tube mounting dimensions; front view.

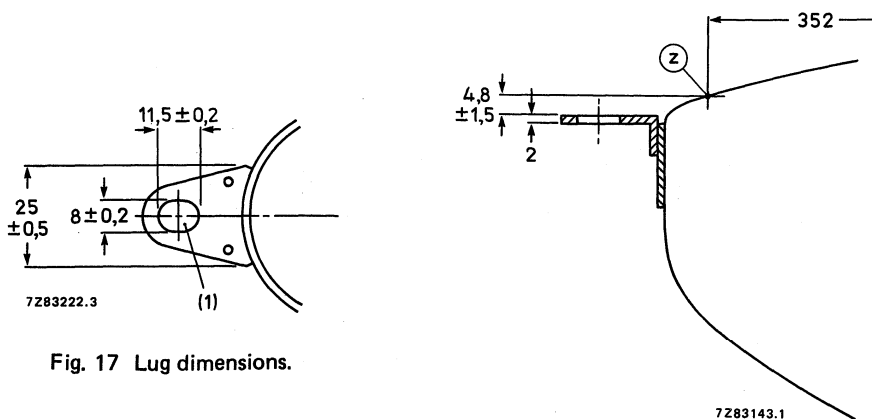

Fig. 17 Lug dimensions.

Fig. 18 Lug position.

(1) The mounting screws in the cabinet must be situated inside a circle of 5 mm diameter drawn around the true geometrical positions i.e. at the corners of a rectangle of 314.3 mm x 247.6 mm.

Front view and lug dimensions of tube M38-334

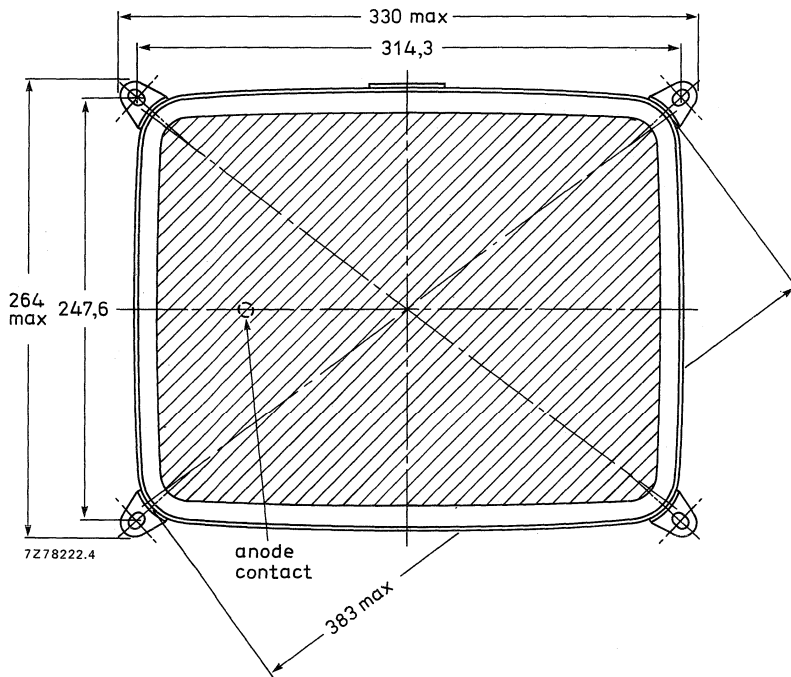

Fig. 19 Tube mounting dimensions; front view.

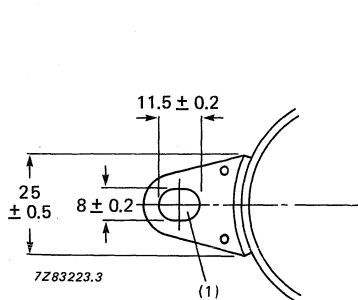

Fig. 20 Lug dimensions

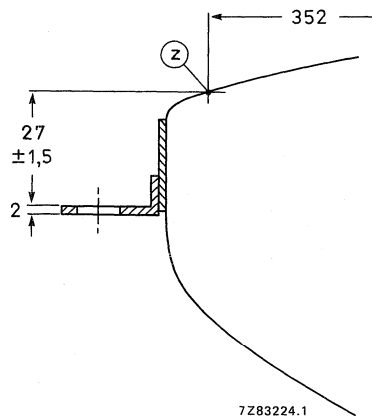

Fig. 21 Lug position.

(1) The mounting screws in the cabinet must be situated inside a circle of 5 mm diameter drawn around the true geometrical positions i.e. at the corners of a rectangle of 314.3 mm x 247.6 mm.

Front view and lug dimensions of tube M38-336

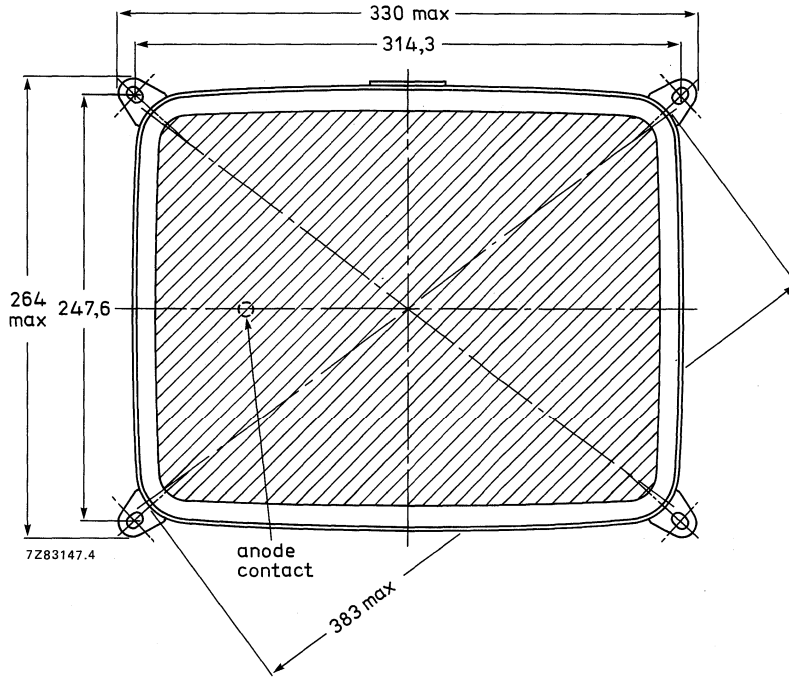

Fig. 22 Tube mounting dimensions; front view.

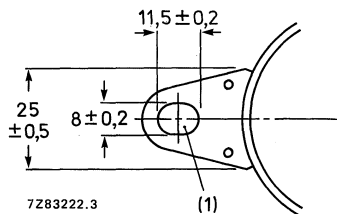

Fig. 23 Lug dimensions.

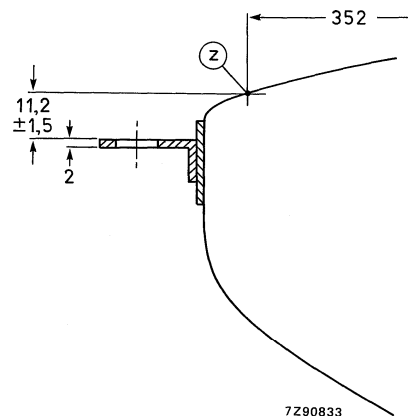

Fig. 24 Lug position.

(1) The mounting screws in the cabinet must be situated inside a circle of 5 mm diameter drawn around the true geometrical positions i.e. at the corners of a rectangle of 314.3 mm x 247.6 mm.

M38-328 M38-330
M38-334 M38-336
M38-338 M38-342

Front view and lug dimensions of tube M38-338

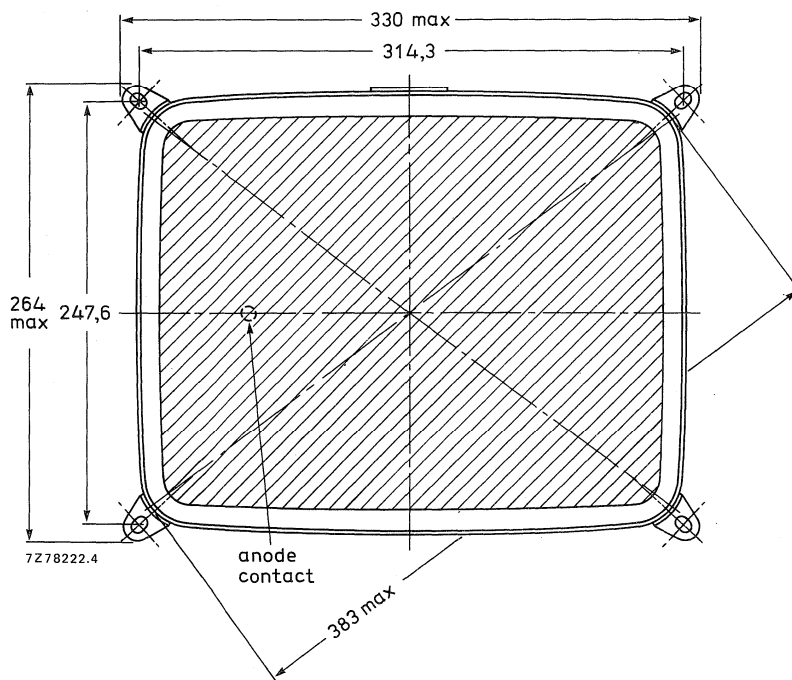

Fig. 25 Tube mounting dimensions; front view.

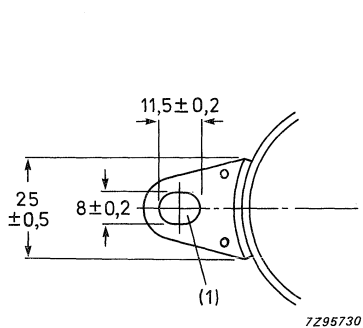

Fig. 26 Lug dimensions.

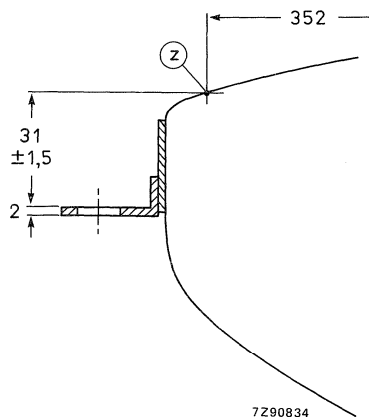

Fig. 27 Lug position.

(1) The mounting screws in the cabinet must be situated inside a circle of 5 mm diameter drawn around the true geometrical positions i.e. at the corners of a rectangle of 314.3 mm x 247.6 mm.

Front view and lug dimensions of tube M38-342

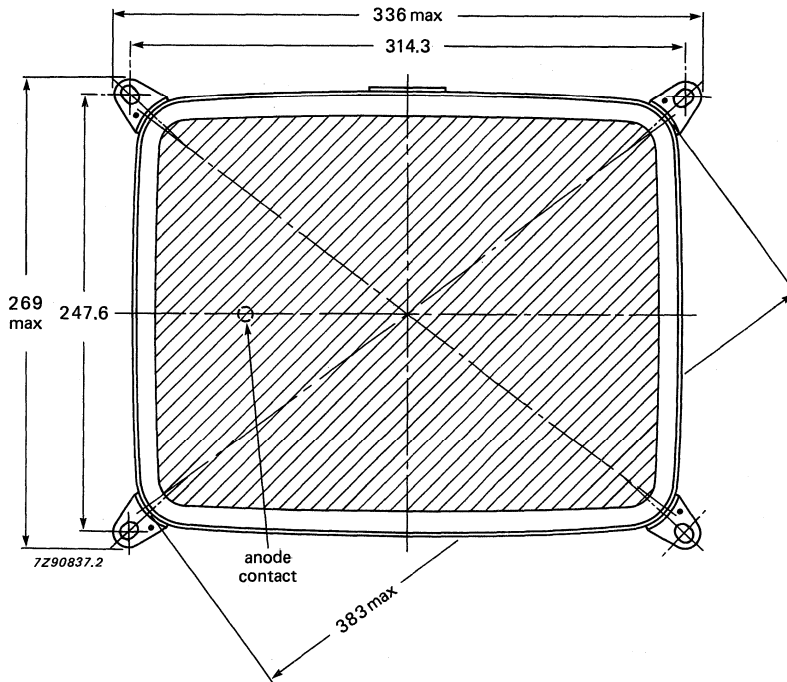

Fig. 28 Tube mounting dimensions; front view.

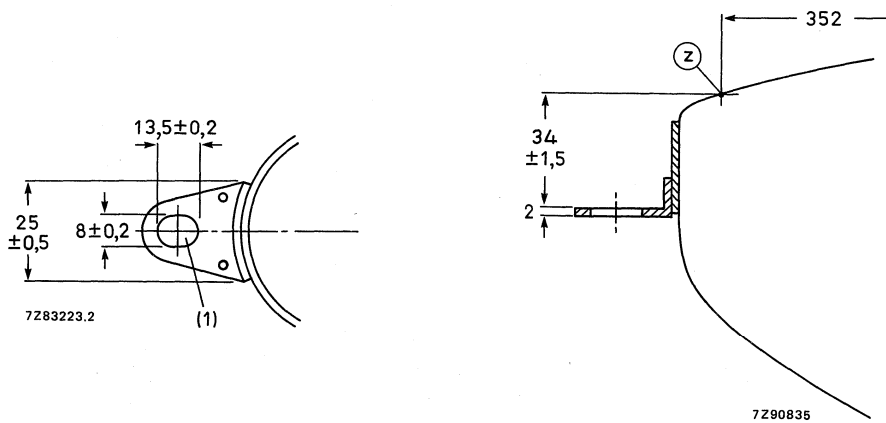

Fig. 29 Lug dimensions

Fig. 30 Lug position.

(1) The mounting screws in the cabinet must be situated inside a circle of 5 mm diameter drawn around the true geometrical positions i.e. at the corners of a rectangle of 314.3 mm x 247.6 mm.

Maximum cone contour

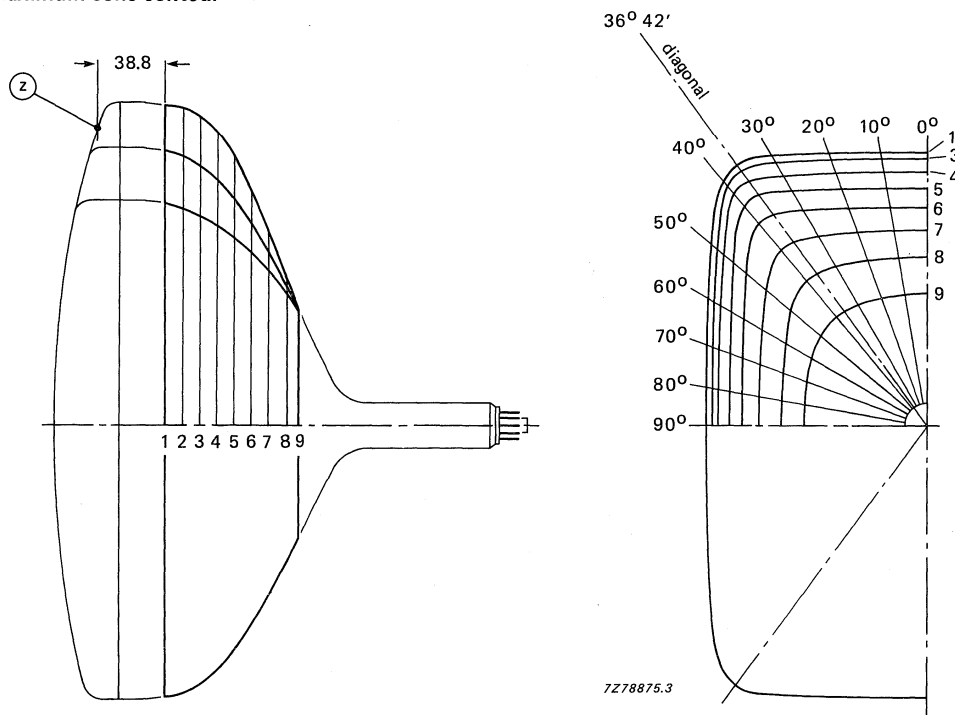

Fig. 31 Cone contour.

Table 1 Cone contour data

sec- tion	nom. distance from section 1	max. distance from centre										
		0°	10°	20°	30°	diag.	40°	50°	60°	70°	80°	90°
1	0	160,0	162,2	168,9	180,8	187,8	185,9	163,3	146,7	136,3	130,6	128,8
2	10	158,2	160,4	167,2	179,3	186,4	184,5	161,6	144,8	134,5	128,8	127,0
3	20	152,8	154,9	161,5	173,6	181,3	179,1	155,7	139,5	129,4	123,9	122,2
4	30	143,4	145,4	151,7	163,1	170,9	169,1	147,1	131,6	122,1	116,8	115,2
5	40	131,3	133,1	138,8	149,0	156,3	155,4	136,6	122,3	113,4	108,6	107,0
6	50	116,9	118,5	123,4	132,0	138,1	138,2	124,1	111,7	103,8	99,5	98,1
7	60	101,1	102,3	106,2	112,4	116,2	116,6	109,5	100,0	93,6	89,9	88,7
8	70	84,5	85,3	87,4	89,9	90,9	91,0	89,4	85,8	82,1	79,7	78,8
9	76,7	67,3	67,3	67,3	67,3	67,3	67,3	67,3	67,3	67,3	67,3	67,3

HIGH RESOLUTION MONOCHROME MONITOR TUBES

- For Data Graphic Displays
- 110° deflection angle
- 38 cm (15 in) face diagonal; rectangular glass
- 28.6 mm neck diameter
- Integral implosion protection

QUICK REFERENCE DATA

Deflection angle	110°
Face diagonal	38 cm (15 in)
Overall length	max. 290 mm
Neck diameter	28.6 mm
Heating	12 V/130 mA
Quick heating cathode	with a typical tube a legible picture will appear within 5 s
Grid 2 voltage	700 V
Anode voltage	17 kV
Resolution	approx. 1500 lines

APPLICATION

This high resolution tube is for alphanumeric and graphic display applications, such as computer terminals, small business computers, etc.

AVAILABLE VERSIONS

The following versions are available: M38-346 and M38-348. Differences between the tubes can be found under 'Dimensional data'.

The tube can be supplied with different phosphors and anti-reflective treatments, see "High resolution monochrome monitor tubes, General".

ELECTRICAL DATA

Focusing method	electrostatic
Deflection method	magnetic
Deflection angles	
diagonal	approx. 110°
horizontal	approx. 98°
vertical	approx. 81°
Direct interelectrode capacitances	
cathode to all other electrodes	max. 5 pF
grid 1 to all other electrodes	max. 9 pF
Capacitance of external conductive coating to anode*	max. 1200 pF min. 600 pF
Capacitance of external conductive coating to anode**	max. 1000 pF min. 500 pF
Capacitance of anode to implosion protection hardware**	approx. 200 pF
Heater voltage	12 V
Heater current at 12 V	130 mA

OPTICAL DATA

Phosphor type	see "High resolution monochrome monitor tubes, General"
Light transmission at screen centre	
tube with normal tinted face glass	approx. 46%
tube with dark tinted face glass	approx. 34%

RASTER CENTRING

The field intensity perpendicular to the tube axis should be adjustable from 0 to 800 A/m. For optimum overall sharpness it is recommended to centre the raster electrically via the deflection coils.

* Implosion protection hardware connected to external conductive coating.

** Implosion protection hardware not connected to external conductive coating.

MECHANICAL DATA (see also the figures under Dimensional Data)

Overall length	max. 290 mm
Greatest dimensions of tube	
diagonal	383 mm
width	324 mm
height	262 mm
Minimum useful screen dimensions (projected)	
diagonal	352 mm
horizontal axis	292 mm
vertical axis	227 mm
area	652 cm ²
Implosion protection	rimband
Bulb	EIAJ-JB370AB03 or EIAJ-JB370AB04
Bulb contact designation	IEC 67-III-2; EIA-J1-21
Base designation	IEC 67-1-31a; EIA-B7-208
Basing	8 HR
Mass	approx. 4 kg

RATINGS (Absolute Maximum System)

Unless otherwise specified voltage values are positive and measured with respect to grid 1.

Anode voltage	max. 19 kV min. 13 kV
Grid 4 (focusing electrode) voltage	-200 to +1000 V
Grid 2 voltage	max. 1000 V min. 400 V
Anode current	
long-term average value	max. 100 μ A
peak value	max. 300 μ A
Cathode voltage, positive peak value	max. 400 V
Heater voltage	12 V +5/-10%*
Cathode-to-heater voltage	max. 100 V

* For maximum cathode life it is recommended that the heater supply be regulated at 12 V $\begin{matrix} +0\% \\ -5\% \end{matrix}$.

CIRCUIT DESIGN VALUES

Grid 4 current		
positive	max.	25 μ A
negative	max.	25 μ A
Grid 2 current		
positive	max.	5 μ A
negative	max.	5 μ A

MAXIMUM CIRCUIT VALUES

Resistance between cathode and heater	max.	1.0 M Ω
Impedance between cathode and heater	max.	0.1 M Ω
Grid 1 circuit resistance	max.	1.5 M Ω
Grid 1 circuit impedance	max.	0.5 M Ω

TYPICAL OPERATING CONDITIONS

Cathode drive; voltages specified with respect to grid 1

Anode voltage	17 kV
Grid 4 (focusing electrode) voltage	0 to 400 V*
Grid 2 voltage	700 V
Cathode cut-off voltage	72 to 112 V**

Grid drive; voltages specified with respect to cathode

Anode voltage	17 kV
Grid 4 (focusing electrode) voltage	0 to 400 V*
Grid 2 voltage	700 V
Grid 1 cut-off voltage	84 to 126 V**

RESOLUTION

The resolution is approx. 1500 lines. It is measured at the screen centre:

- with shrinking raster method,
- at light output 68,5 cd/m² (20 foot lambert) and raster dimensions 259 mm x 194 mm,
- at $V_{g2} = 700$ V and anode voltage = 17 kV,
- with phosphor type W (WW),
- with normal tinted face glass, without anti-glare treatment of screen surface.

X-RADIATION CHARACTERISTIC

X-radiation emitted will not exceed 0,5 mR/h throughout the useful life of the tube, when operated within the given ratings.

* Measured at screen centre on spot at anode current = 250 μ A (peak), anode voltage = 17 kV, grid 2 voltage = 700 V.

Dynamic focus (only for optimization): Typical correction for a video field of
 H x V = 259 mm x 194 mm (landscape format): line parabola 300 V, field parabola 100 V;
 H x V = 194 mm x 259 mm (portrait format): line parabola 200 V, field parabola 250 V.

** Visual extinction of focused raster.

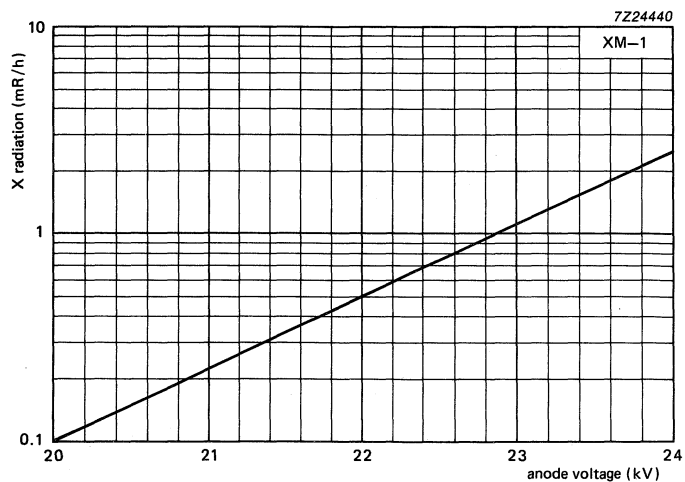

Fig. 1 X-radiation limit curve according to JEDEC 94, at a constant anode current of 250 μ A, measured according to TEPAC103A.

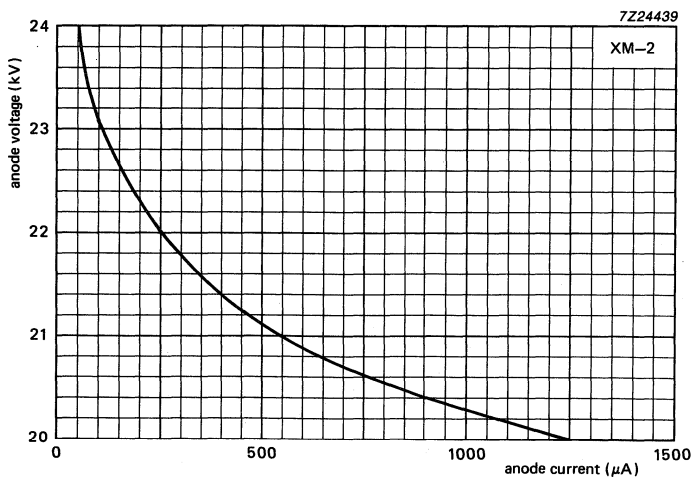

Fig. 2 0,5 mR/h isoexposure rate limit curve, according to JEDEC 94, measured according to TEPAC103A.

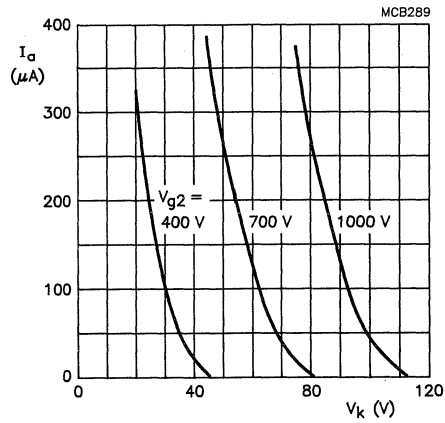

Fig. 3 Anode current as a function of cathode voltage.
Cathode drive; $V_{a,g3,g5} = 17$ kV.

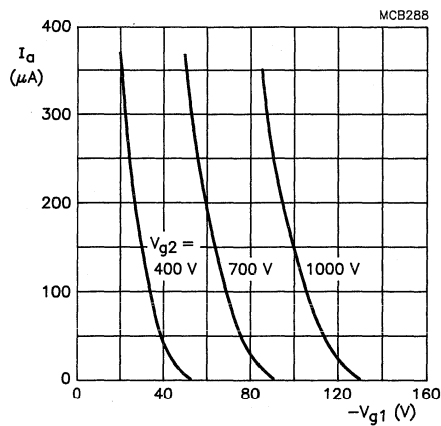

Fig. 4 Anode current as a function of grid 1 voltage.
Grid drive; $V_{a,g3,g5} = 17$ kV.

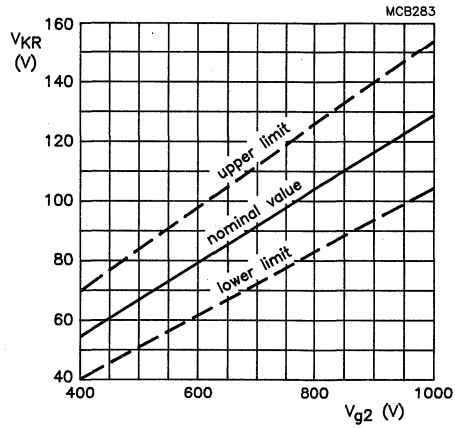

Fig. 5 Limits of cathode cut-off voltage as a function of grid 2 voltage. Cathode drive; $V_{a,g3,g5} = 17$ kV.

$$\frac{\Delta V_{KR}}{\Delta V_{a,g3,g5}} = 0.15 \times 10^{-3}$$

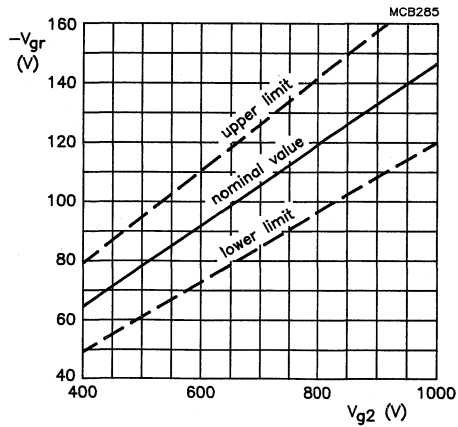

Fig. 6 Limits of grid 1 cut-off voltage as a function of grid 2 voltage. Grid drive; $V_{a,g3,g5} = 17$ kV.

$$\frac{\Delta V_{GR}}{\Delta V_{a,g3,g5}} = 0.15 \times 10^{-3}$$

DIMENSIONAL DATA

Dimensions in mm

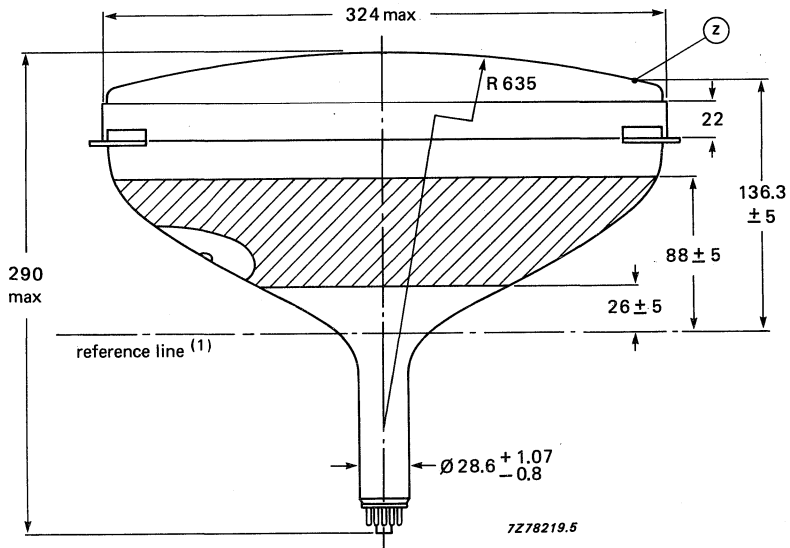

Fig. 7.

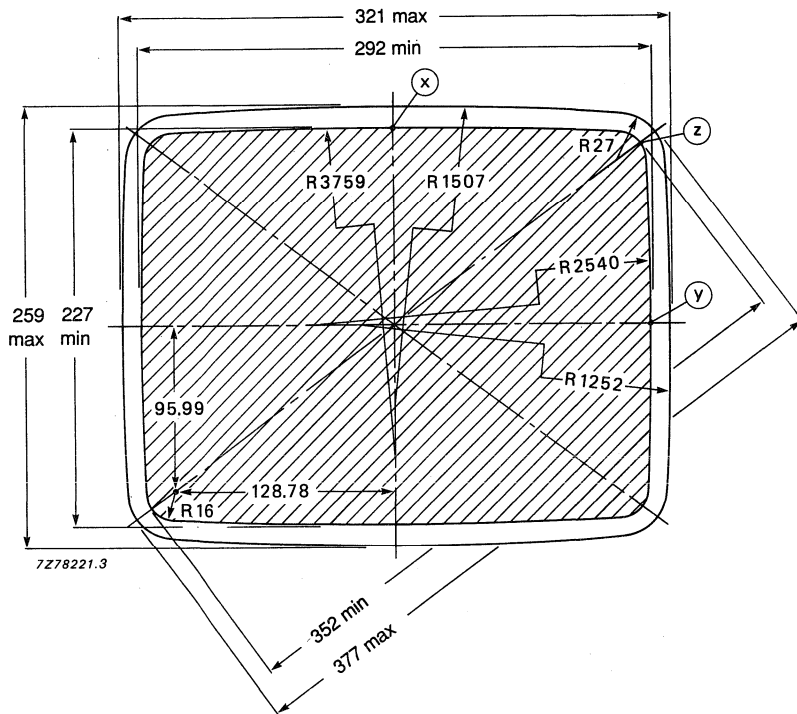

Fig. 8.

(1) The reference line is determined by the plane of the upper edge of reference line gauge C when the gauge is resting on the cone.

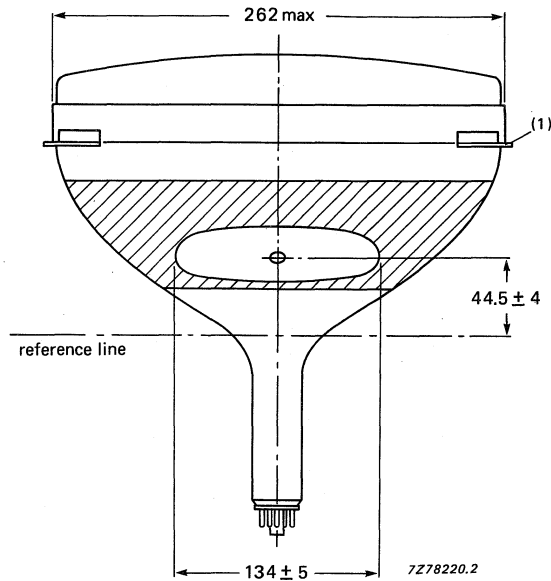

Fig. 9.

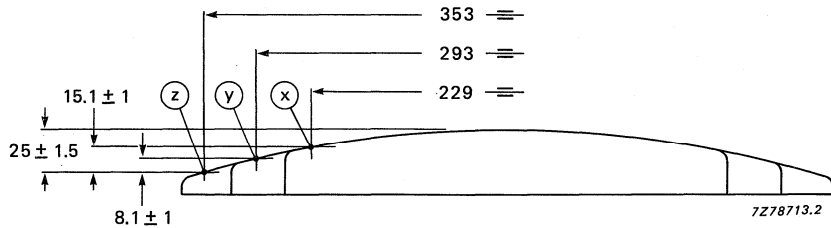

Fig. 10 Screen reference points.

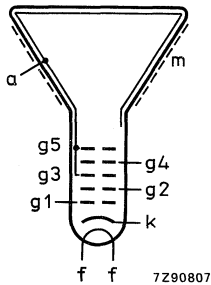

Fig. 11 Electrode configuration.

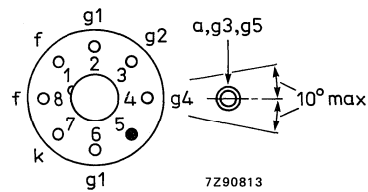

Fig. 12 Pin arrangement.

(1) The displacement of any lug with respect to the plane through the three other lugs is max. 1.5 mm.

Front view and lug dimensions of tube M38-346

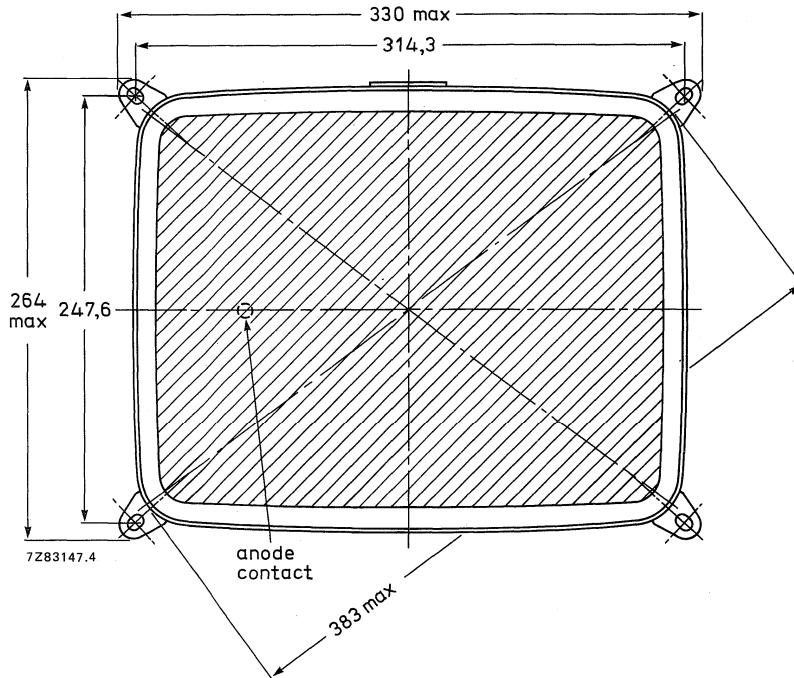

Fig. 13 Tube mounting dimensions; front view.

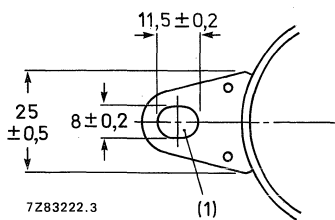

Fig. 14 Lug dimensions.

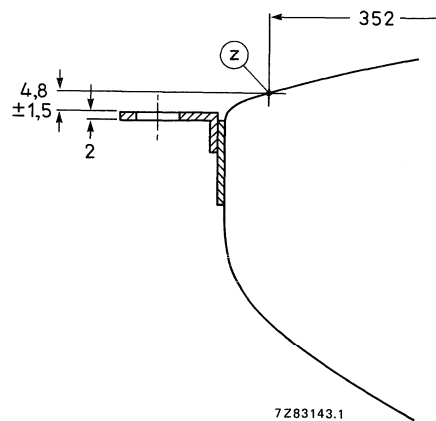

Fig. 15 Lug position.

(1) The mounting screws in the cabinet must be situated inside a circle of 5 mm diameter drawn around the true geometrical positions i.e. at the corners of a rectangle of 314.3 mm x 247.6 mm.

Front view and lug dimensions of tube M38-348

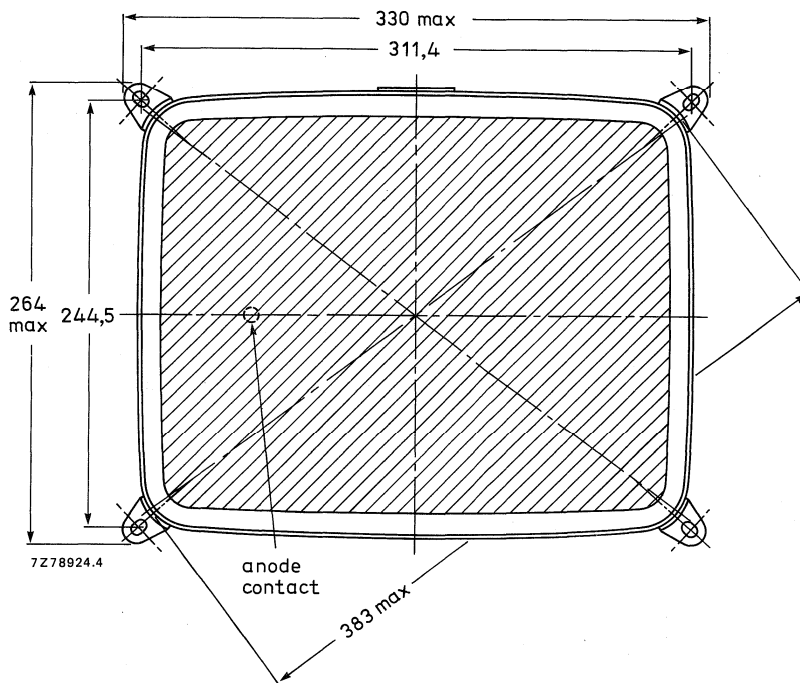

Fig. 16 Tube mounting dimensions; front view.

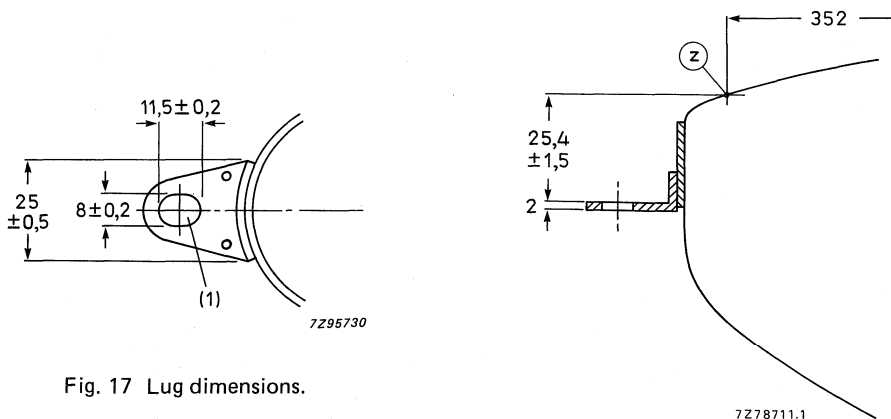

Fig. 17 Lug dimensions.

Fig. 18 Lug position.

(1) The mounting screws in the cabinet must be situated inside a circle of 5 mm diameter drawn around the true geometrical positions i.e. at the corners of a rectangle of 311.4 mm x 244.5 mm.

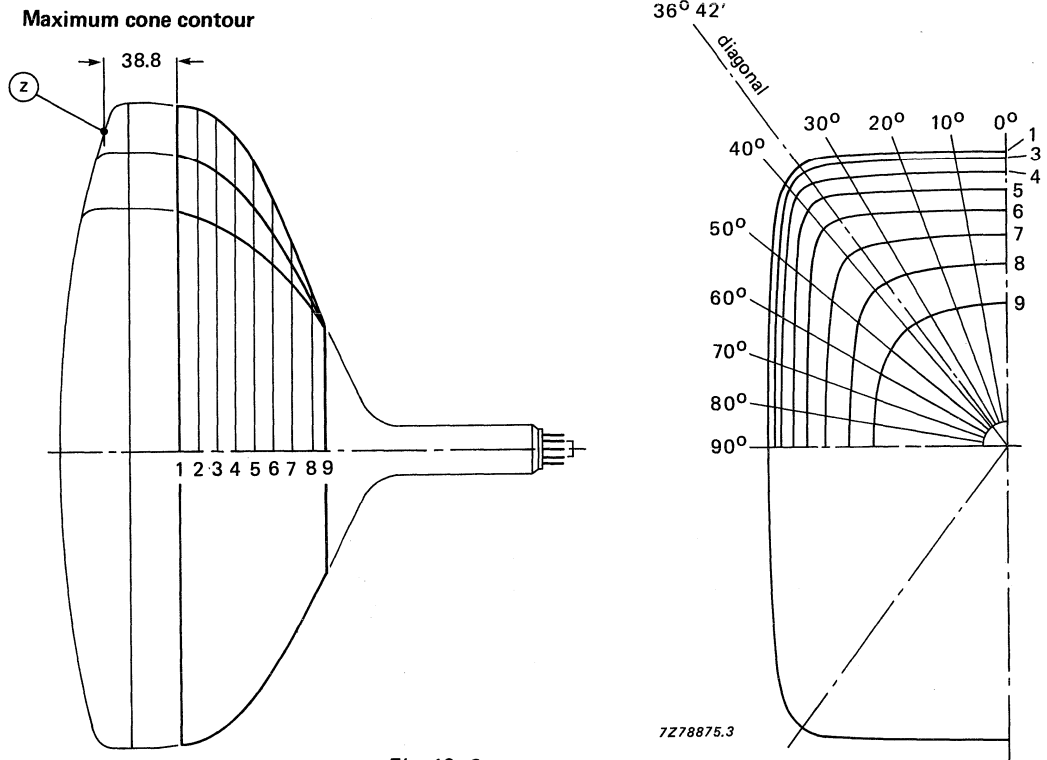

Fig. 19 Cone contour.

Table 1 Cone contour data

sec- tion	nom. distance from section 1	max. distance from centre										
		0°	10°	20°	30°	diag.	40°	50°	60°	70°	80°	90°
1	0	160,0	162,2	168,9	180,8	187,8	185,9	163,3	146,7	136,3	130,6	128,8
2	10	158,2	160,4	167,2	179,3	186,4	184,5	161,6	144,8	134,5	128,8	127,0
3	20	152,8	154,9	161,5	173,6	181,3	179,1	155,7	139,5	129,4	123,9	122,2
4	30	143,4	145,4	151,7	163,1	170,9	169,1	147,1	131,6	122,1	116,8	115,2
5	40	131,3	133,1	138,8	149,0	156,3	155,4	136,6	122,3	113,4	108,6	107,0
6	50	116,9	118,5	123,4	132,0	138,1	138,2	124,1	111,7	103,8	99,5	98,1
7	60	101,1	102,3	106,2	112,4	116,2	116,6	109,5	100,0	93,6	89,9	88,7
8	70	84,5	85,3	87,4	89,9	90,9	91,0	89,4	85,8	82,1	79,7	78,8
9	76,7	67,3	67,3	67,3	67,3	67,3	67,3	67,3	67,3	67,3	67,3	67,3

HIGH RESOLUTION MONOCHROME MONITOR TUBE

- For Data Graphic Displays
- 114° deflection angle
- 44 cm (17 in) face diagonal; rectangular glass
- 28.6 mm neck diameter
- Integral implosion protection

QUICK REFERENCE DATA

Deflection angle	114°
Face diagonal	44 cm (17 in)
Overall length	max. 302 mm
Neck diameter	28.6 mm
Heating	6.3 V/240 mA
Quick heating cathode	with a typical tube a legible picture will appear within 5 s
Grid 2 voltage	700 V
Anode voltage	20 kV
Resolution	approx. 1500 lines

APPLICATION

This high resolution tube is for alphanumeric and graphic display applications, such as computer terminals, etc.

The tube can be supplied with different phosphors, see "High resolution monochrome monitor tubes, General".

ELECTRICAL DATA

Focusing method	electrostatic
Deflection method	magnetic
Deflection angles	
diagonal	approx. 114°
horizontal	approx. 104°
vertical	approx. 90°
Direct interelectrode capacitances	
cathode to all other electrodes	max. 5 pF
grid 1 to all other electrodes	max. 9 pF
Capacitance of external conductive coating to anode*	max. 1500 pF min. 800 pF
Capacitance of external conductive coating to anode**	max. 1300 pF min. 700 pF
Capacitance of anode to implosion protection hardware**	approx. 200 pF
Heater voltage	6,3 V
Heater current at 6,3 V	240 mA

OPTICAL DATA

Phosphor type	see "High resolution monochrome monitor tubes, General"
Light transmission at screen centre (normal tinted glass)	approx. 48%

RASTER CENTRING

The field intensity perpendicular to the tube axis should be adjustable from 0 to 800 A/m. For optimum overall sharpness it is recommended to centre the raster electrically via the deflection coils.

* Implosion protection hardware connected to external conductive coating.

** Implosion protection hardware not connected to external conductive coating.

MECHANICAL DATA (see also the figures under Dimensional Data)

Overall length	max. 302 mm
Greatest dimensions of tube	
diagonal	441 mm
width	377 mm
height	302 mm
Minimum useful screen dimensions (projected)	
diagonal	413 mm
horizontal axis	346 mm
vertical axis	270 mm
area	912 cm ²
Implosion protection	rimband
Bulb	EIA J436A
Bulb contact designation	IEC 67-III-2; EIA J1-21
Base designation	IEC 67-1-31a; EIA B7-208
Basing	8 HR
Mass	approx. 6 kg

RATINGS (Absolute Maximum System)

Unless otherwise specified voltage values are positive and measured with respect to grid 1.

Anode voltage	max. 21 kV min. 15 kV
Grid 4 (focusing electrode) voltage	-200 to +1000 V
Grid 2 voltage	max. 1000 V min. 400 V
Anode current	
long-term average value	max. 100 μ A
peak value	max. 300 μ A
Cathode voltage, positive peak value	max. 400 V
Heater voltage	6,3 V +5/-10%*
Cathode-to-heater voltage	max. 100 V

* For maximum cathode life it is recommended that the heater supply be regulated at 6,3 V $\begin{matrix} +0\% \\ -5\% \end{matrix}$.

CIRCUIT DESIGN VALUES

Grid 4 current	
positive	max. 25 μ A
negative	max. 25 μ A
Grid 2 current	
positive	max. 5 μ A
negative	max. 5 μ A

MAXIMUM CIRCUIT VALUES

Resistance between cathode and heater	max. 1,0 M Ω
Impedance between cathode and heater	max. 0,1 M Ω
Grid 1 circuit resistance	max. 1,5 M Ω
Grid 1 circuit impedance	max. 0,5 M Ω

TYPICAL OPERATING CONDITIONS

Cathode drive; voltages specified with respect to grid 1

Anode voltage	20 kV
Grid 4 (focusing electrode) voltage	0 to 400 V*
Grid 2 voltage	700 V
Cathode cut-off voltage	72 to 112 V**

Grid drive; voltages specified with respect to cathode

Anode voltage	20 kV
Grid 4 (focusing electrode) voltage	0 to 400 V*
Grid 2 voltage	700 V
Grid 1 cut-off voltage	84 to 126 V**

RESOLUTION

The resolution is approx. 1500 lines. It is measured at the screen centre:

- with shrinking raster method,
- at light output 68,5 cd/m² (20 foot lambert) and raster dimensions 304 mm x 228 mm,
- at $V_{g2} = 700$ V and anode voltage = 20 kV,
- with phosphor type W (WW),
- with normal tinted face glass, without anti-glare treatment of screen surface.

X-RADIATION CHARACTERISTIC

X-radiation emitted will not exceed 0,5 mR/h throughout the useful life of the tube, when operated within the given ratings.

* Measured at screen centre on spot at anode current = 250 μ A (peak), anode voltage = 20 kV, grid 2 voltage = 700 V.

Dynamic focus (only for optimization): Typical correction for a video field of H x V = 304 mm x 228 mm (landscape format): line parabola 300 V, field parabola 100 V.

** Visual extinction of focused raster.

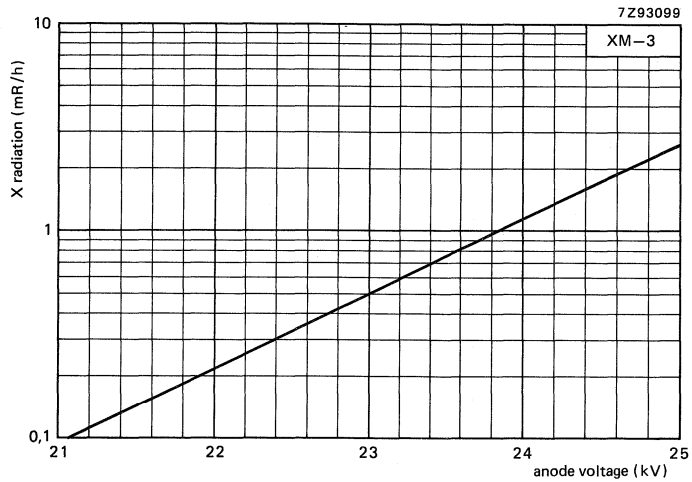

Fig. 1 X-radiation limit curve according to JEDEC 94, at a constant anode current of $250 \mu\text{A}$, measured according to TEPAC103A.

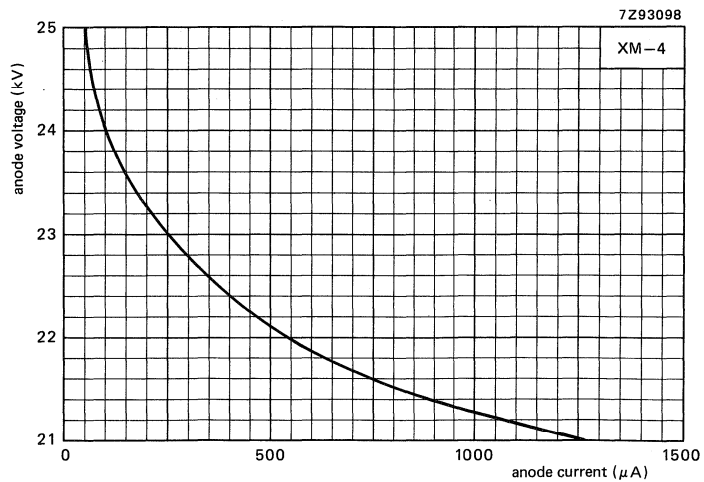

Fig. 2 0,5 mR/h isosexposure rate limit curve, according to JEDEC 94, measured according to TEPAC103A.

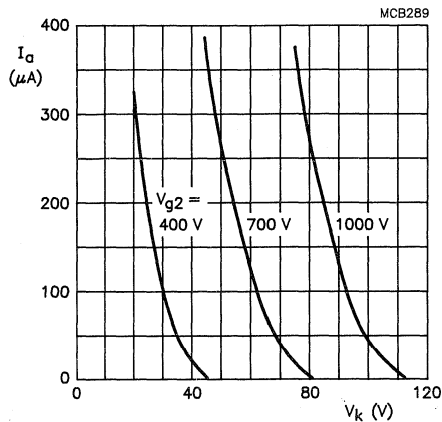

Fig. 3 Anode current as a function of cathode voltage.
Cathode drive; $V_{a,g3,g5} = 20$ kV.

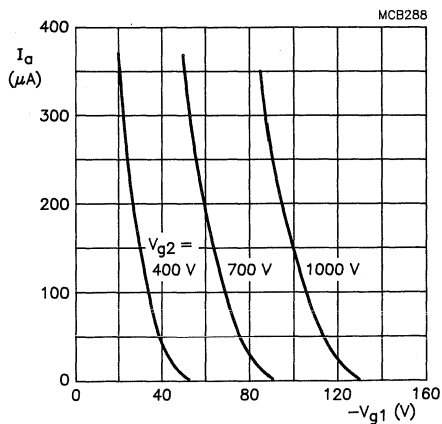

Fig. 4 Anode current as a function of grid 1 voltage.
Grid drive; $V_{a,g3,g5} = 20$ kV.

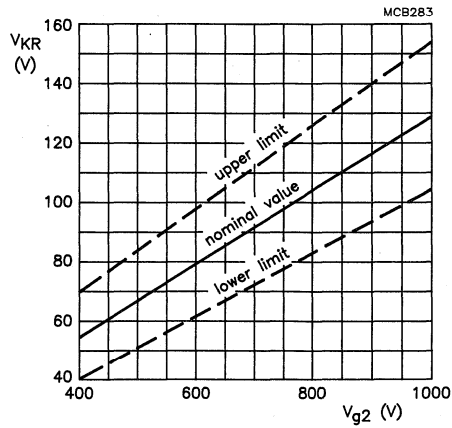

Fig. 5 Limits of cathode raster cut-off voltage as a function of grid 2 voltage. Cathode drive; $V_{a,g3,g5} = 20$ kV.

$$\frac{\Delta V_{KR}}{\Delta V_{a,g3,g5}} = 0,15 \times 10^{-3}.$$

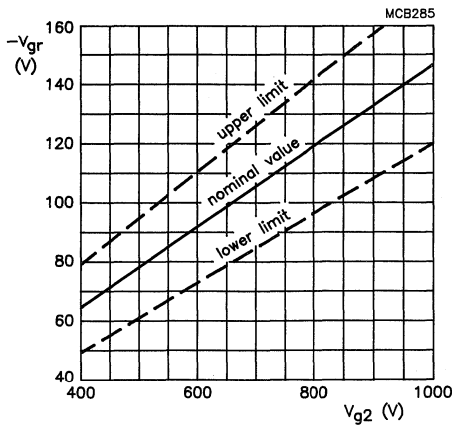

Fig. 6 Limits of grid 1 raster cut-off voltage as a function of grid 2 voltage. Grid drive; $V_{a,g3,g5} = 20$ kV.

$$\frac{\Delta V_{GR}}{\Delta V_{a,g3,g5}} = 0,15 \times 10^{-3}.$$

DIMENSIONAL DATA

Dimensions in mm

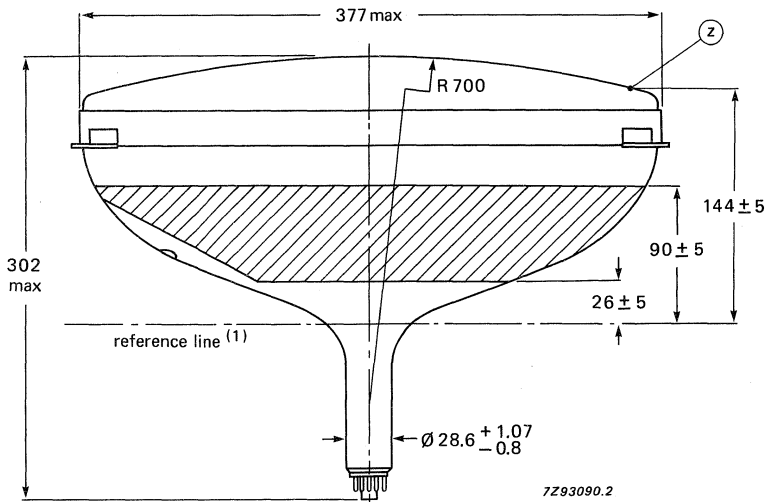

Fig. 7

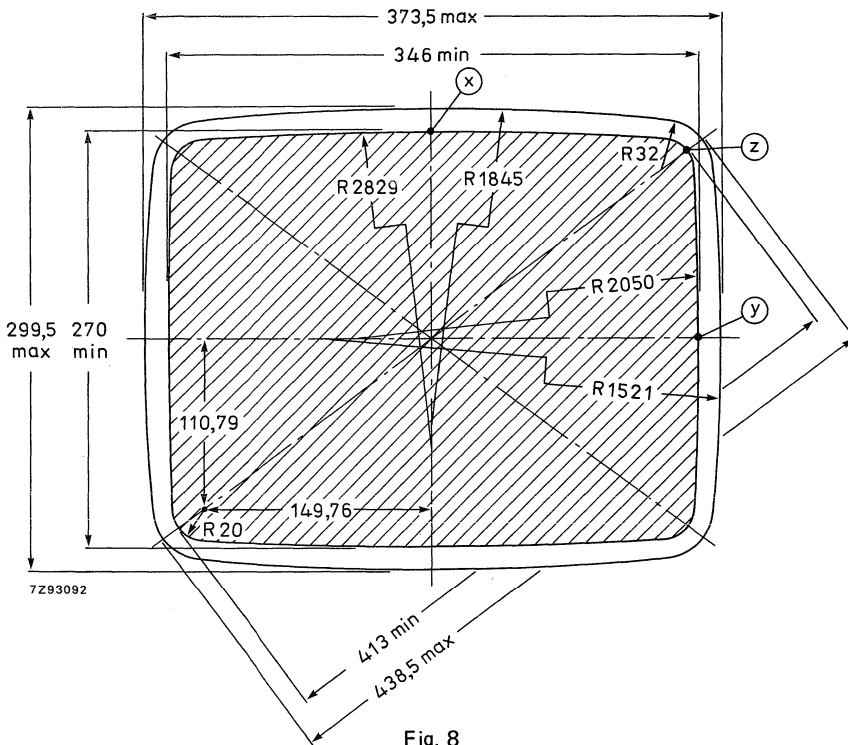

Fig. 8

(1) The reference line is determined by the plane of the upper edge of reference line gauge C when the gauge is resting on the cone.

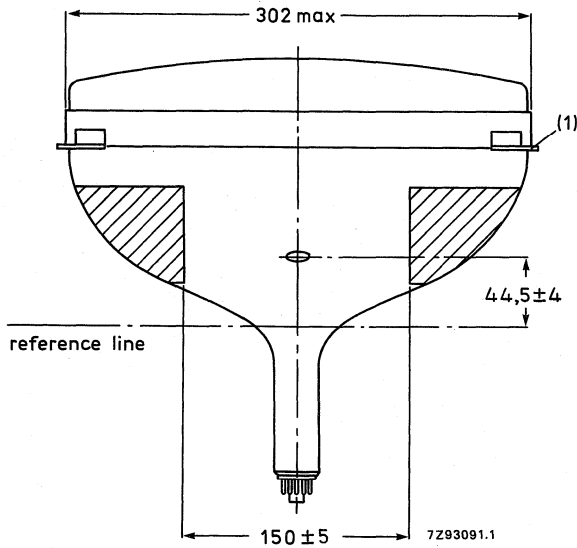

Fig. 9

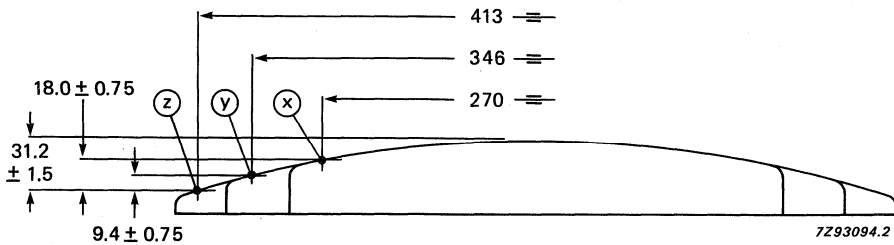

Fig. 10 Screen reference points.

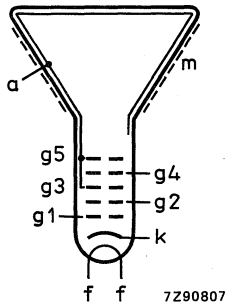

Fig. 11 Electrode configuration.

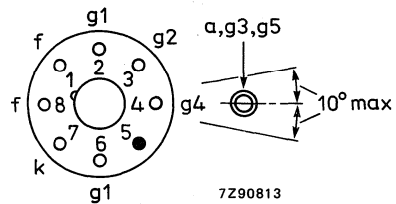

Fig. 12 Pin arrangement.

(1) The displacement of any lug with respect to the plane through the three other lugs is max. 1.5 mm.

Front view and lug dimensions

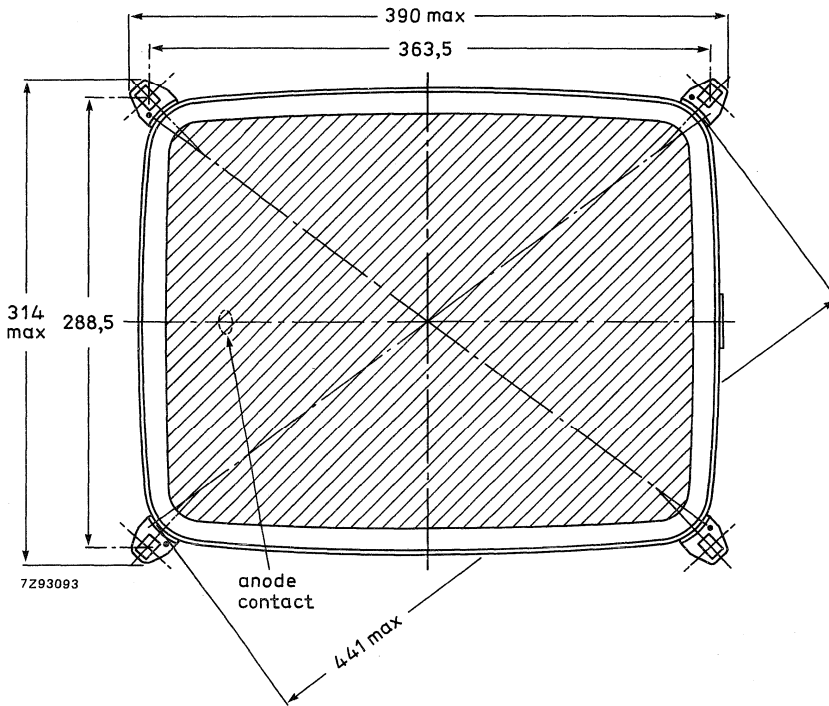

Fig. 13 Tube mounting dimensions; front view.

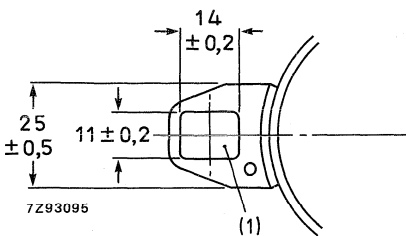
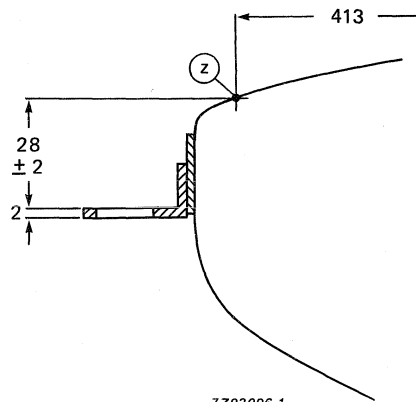

Fig. 14 Lug dimensions.



7293096.1
Fig. 15 Lug position.

(1) The mounting screws in the cabinet must be situated inside a circle of 7.5 mm diameter drawn around the true geometrical positions i.e. at the corners of a rectangle of 363.5 mm x 288.5 mm.

Maximum cone contour

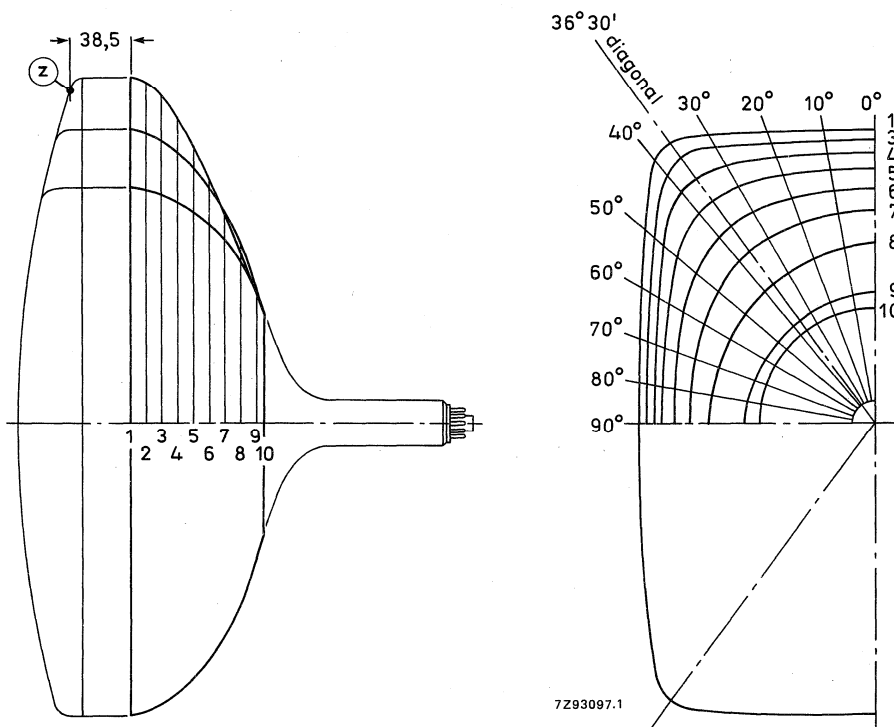

Fig. 16 Cone contour.

Table 1 Cone contour data.

sec- tion	nom. distance from section 1	maximum distance from centre										
		0°	10°	20°	30°	diag.	40°	50°	60°	70°	80°	90°
1	0	184,30	186,83	194,73	209,03	217,15	214,63	187,58	168,13	156,09	149,50	147,40
2	10	183,80	186,32	194,20	208,43	216,54	213,94	187,05	167,67	155,65	149,08	146,98
3	20	180,84	183,29	190,91	204,44	211,90	209,50	184,37	165,42	153,62	147,15	145,09
4	30	174,11	176,34	183,17	194,20	198,87	196,98	177,67	160,30	149,18	143,04	141,08
5	40	164,91	166,81	172,30	179,31	180,94	179,45	167,16	153,19	143,33	137,76	135,96
6	50	153,13	154,62	158,32	161,71	161,74	160,61	153,27	143,62	135,70	130,89	129,30
7	60	139,16	140,03	141,57	142,18	141,40	140,51	136,34	130,86	125,72	122,16	120,87
8	70	122,37	122,17	121,41	120,06	118,91	118,22	116,10	113,94	112,02	110,62	110,05
9	80	94,64	93,90	92,73	91,60	91,01	90,75	90,28	90,23	90,58	91,22	91,76
10	89,34	61,83	61,83	61,83	61,83	61,83	61,83	61,83	61,83	61,83	61,83	61,83

HIGH RESOLUTION MONOCHROME MONITOR TUBE

- For Data Graphic Displays
- 114° deflection angle
- 50 cm (20 in) face diagonal; rectangular glass
- 28.6 mm neck diameter
- Integral implosion protection

QUICK REFERENCE DATA

Deflection angle	114°
Face diagonal	50 cm (20 in)
Overall length	max. 330 mm
Neck diameter	28.6 mm
Heating	6.3 V/240 mA
Quick heating cathode	with a typical tube a legible picture will appear within 5 s
Grid 2 voltage	700 V
Anode voltage	20 kV
Resolution	approx. 1400 lines

APPLICATION

These high resolution tubes are for alphanumeric and graphic display applications, such as computer terminals, etc.

AVAILABLE VERSIONS

The following versions are available: M47EAA and M47EAB. Differences between the tubes can be found under 'Dimensional data'.

These tubes can be supplied with different phosphors, see "High resolution monochrome monitor tubes, General".

ELECTRICAL DATA

Focusing method	electrostatic
Deflection method	magnetic
Deflection angles	
diagonal	approx. 114°
horizontal	approx. 104°
vertical	approx. 90°
Direct interelectrode capacitances	
cathode to all other electrodes	max. 5 pF
grid 1 to all other electrodes	max. 9 pF
Capacitance of external conductive coating to anode*	max. 1875 pF min. 1225 pF
Capacitance of external conductive coating to anode**	max. 1500 pF min. 1000 pF
Capacitance of anode to implosion protection hardware**	approx. 250 pF
Heater voltage	6,3 V
Heater current at 6,3 V	240 mA

OPTICAL DATA

Phosphor type	see "High resolution monochrome monitor tubes, General"
Light transmission at screen centre	
tube with normal tinted glass	approx. 46%
tube with dark tinted glass	approx. 32%

RASTER CENTRING

The field intensity perpendicular to the tube axis should be adjustable from 0 to 800 A/m. For optimum overall sharpness it is recommended to centre the raster electrically via the deflection coils.

* Implosion protection hardware connected to external conductive coating.

** Implosion protection hardware not connected to external conductive coating.

MECHANICAL DATA (see also the figures under Dimensional Data)

Overall length	max. 330 mm
Greatest dimensions of tube	
diagonal	504.5 mm
width	430.5 mm
height	346.5 mm
Minimum useful screen dimensions (projected)	
diagonal	473 mm
horizontal axis	394 mm
vertical axis	308 mm
area	1187 cm ²
Implosion protection	rimband
Bulb	EIA J500A
Bulb contact designation	IEC 67-III-2; EIA J1-21
Base designation	IEC 67-1-31a; EIA B7-208
Basing	8 HR
Mass	approx. 8.5 kg

RATINGS (Absolute Maximum System)

Unless otherwise specified voltage values are positive and measured with respect to grid 1.

Anode voltage	max. 23 kV min. 16 kV
Grid 4 (focusing electrode) voltage	-200 to + 1000 V
Grid 2 voltage	max. 1000 V min. 400 V
Anode current	
long-term average value	max. 100 μ A
peak value	max. 300 μ A
Cathode voltage, positive peak value	max. 400 V
Heater voltage	6.3 V + 5/-10%*
Cathode-to-heater voltage	max. 100 V

* For maximum cathode life it is recommended that the heater supply be regulated at 6.3 V $\begin{matrix} +0\% \\ -5\% \end{matrix}$.

CIRCUIT DESIGN VALUES

Grid 4 current	
positive	max. 25 μ A
negative	max. 25 μ A
Grid 2 current	
positive	max. 5 μ A
negative	max. 5 μ A

MAXIMUM CIRCUIT VALUES

Resistance between cathode and heater	max. 1.0 $M\Omega$
Impedance between cathode and heater	max. 0.1 $M\Omega$
Grid 1 circuit resistance	max. 1.5 $M\Omega$
Grid 1 circuit impedance	max. 0.5 $M\Omega$

TYPICAL OPERATING CONDITIONS

Cathode drive; voltages specified with respect to grid 1

Anode voltage	20 kV
Grid 4 (focusing electrode) voltage	0 to 400 V*
Grid 2 voltage	700 V
Cathode cut-off voltage	72 to 112 V**

Grid drive; voltages specified with respect to cathode

Anode voltage	20 kV
Grid 4 (focusing electrode) voltage	0 to 400 V*
Grid 2 voltage	700 V
Grid 1 cut-off voltage	84 to 126 V**

RESOLUTION

The resolution is approx. 1400 lines. It is measured at the screen centre:

- with shrinking raster method,
- at light output 68.5 cd/m² (20 foot lambert) and raster dimensions 348 mm x 261 mm,
- at $V_{g2} = 700$ V and anode voltage = 20 kV,
- with phosphor type W (WW),
- with normal tinted face glass, without anti-glare treatment of screen surface.

X-RADIATION CHARACTERISTIC

X-radiation emitted will not exceed 0,5 mR/h throughout the useful life of the tube, when operated within the given ratings.

* Measured at screen centre on spot at anode current = 250 μ A (peak), anode voltage = 20 kV, grid 2 voltage = 700 V.

Dynamic focus (only for optimization): Typical correction for a video field of H x V = 348 mm x 261 mm (landscape format): line parabola 300 V, field parabola 100 V.

** Visual extinction of focused raster.

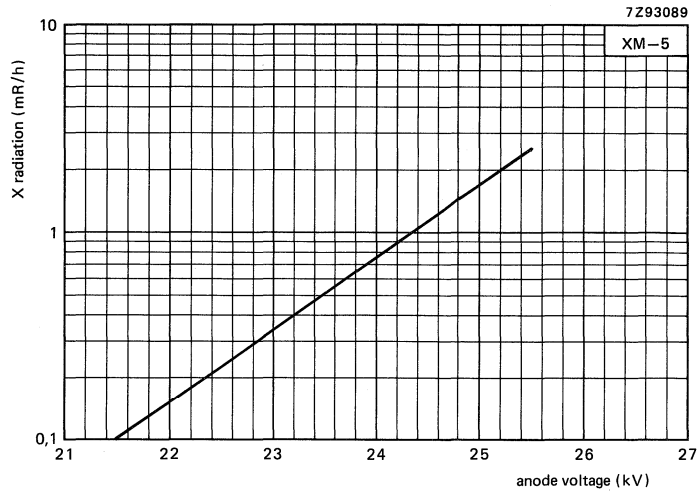

Fig. 1 X-radiation limit curve according to JEDEC 94, at a constant anode current of 250 μA , measured according to TEPAC103A.

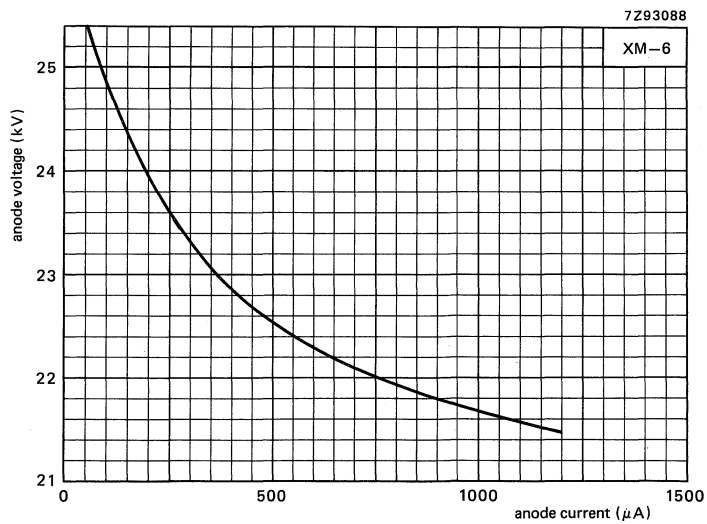

Fig. 2 0.5 mR/h isoexposure rate limit curve, according to JEDEC 94, measured according to TEPAX103A.

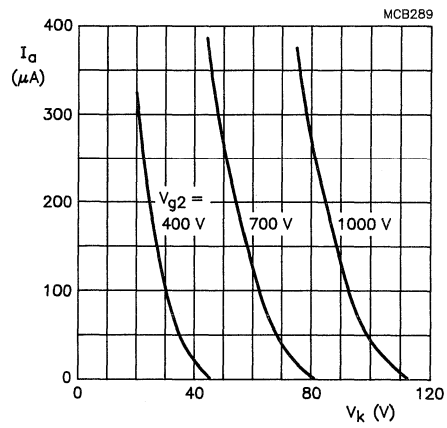

Fig. 3 Anode current as a function of cathode voltage.
Cathode drive; $V_{a,g3,g5} = 20$ kV.

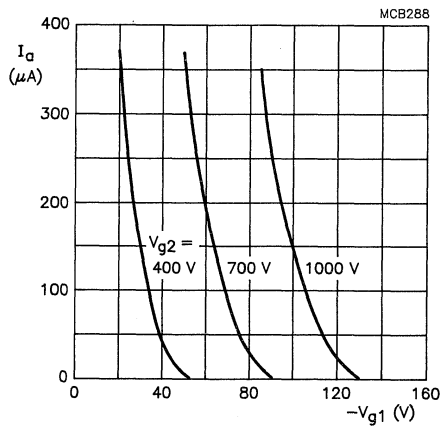

Fig. 4 Anode current as a function of grid 1 voltage.
Grid drive; $V_{a,g3,g5} = 20$ kV.

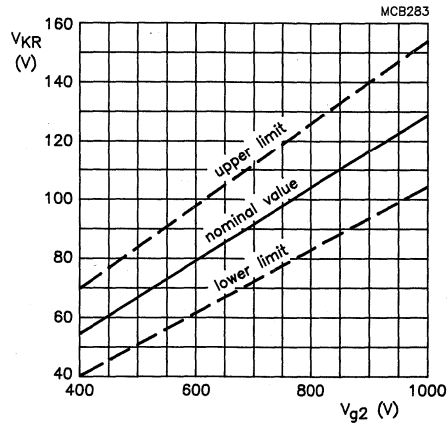

Fig. 5 Limits of cathode raster cut-off voltage as a function of grid 2 voltage.
Cathode drive; $V_{a,g3,g5} = 20$ kV.

$$\frac{\Delta V_{KR}}{\Delta V_{a,g3,g5}} = 0.15 \times 10^{-3}$$

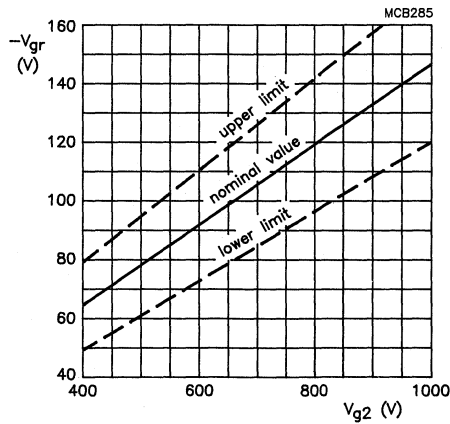
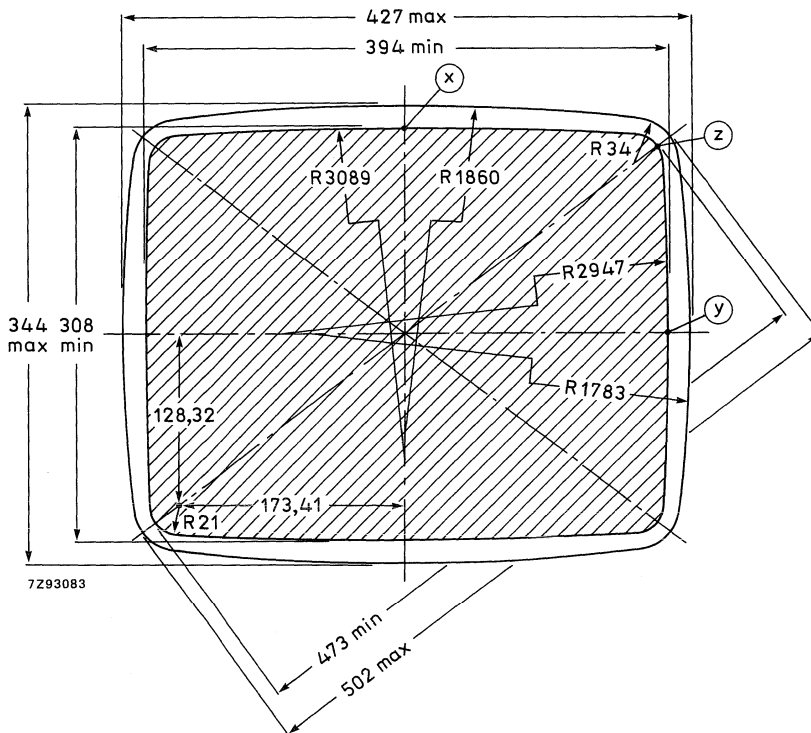
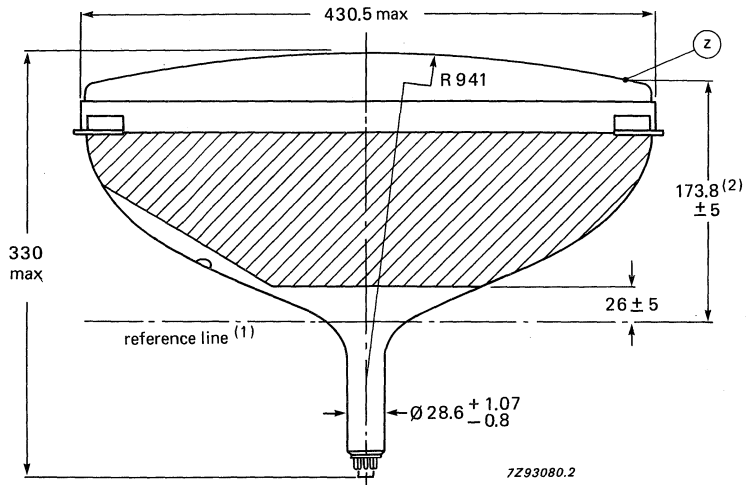

Fig. 6 Limits of grid 1 raster cut-off voltage as a function of grid 2 voltage.
Grid drive; $V_{a,g3,g5} = 20$ kV.

$$\frac{\Delta V_{GR}}{\Delta V_{a,g3,g5}} = 0.15 \times 10^{-3}$$

DIMENSIONAL DATA

Dimensions in mm



- (1) The reference line is determined by the plane of the upper edge of reference line gauge C when the gauge is resting on the cone.
 (2) If NEG type, this value changes to 170.3 ± 5 .

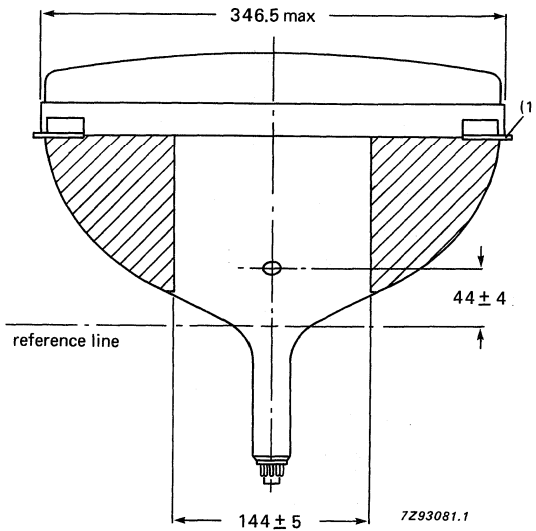

Fig. 9.

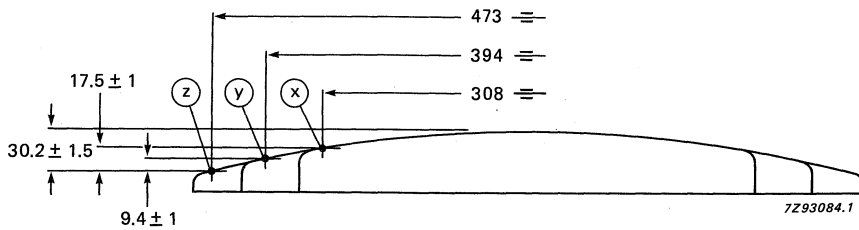

Fig. 10 Screen reference points.

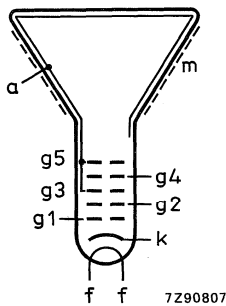

Fig. 11 Electrode configuration.

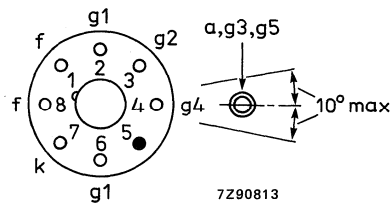

Fig. 12 Pin arrangement.

(1) The displacement of any lug with respect to the plane through the three other lugs is max. 1.5 mm.

Front view and lug dimensions of tube M47EAA

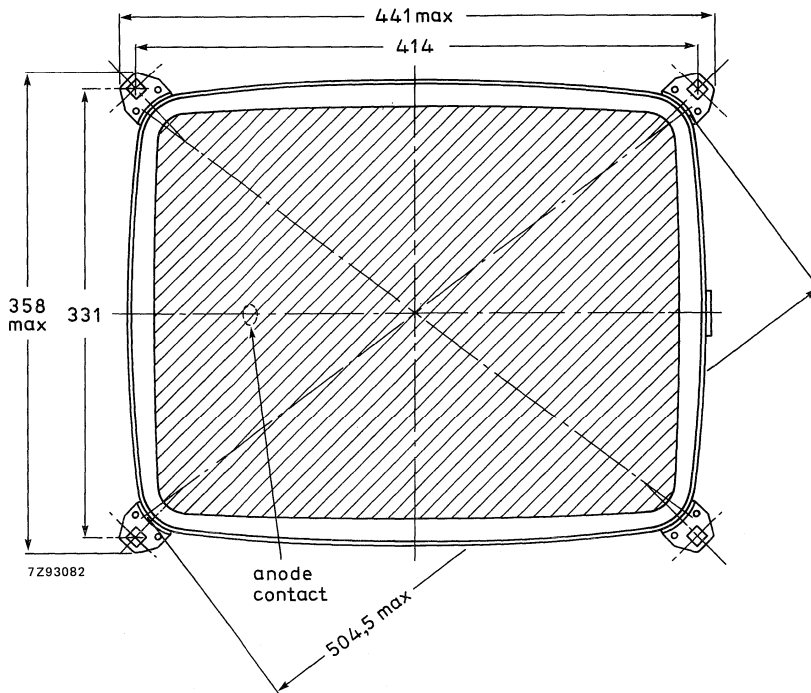

Fig. 13 Tube mounting dimensions; front view.

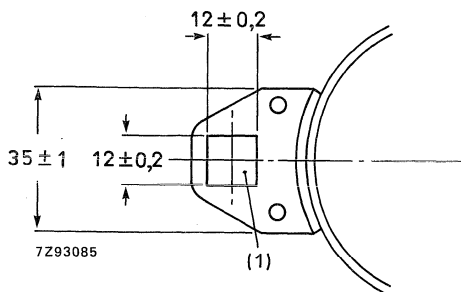

Fig. 14 Lug dimensions.

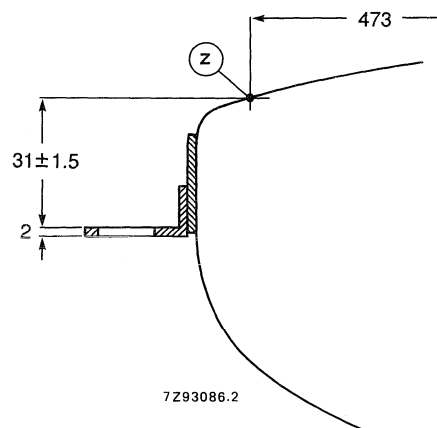

Fig. 15 Lug position.

(1) The mounting screws in the cabinet must be situated inside a circle of 8 mm diameter drawn around the true geometrical positions i.e. at the corners of a rectangle of 414 mm x 331 mm.

Front view and lug dimensions of tube M47EAB

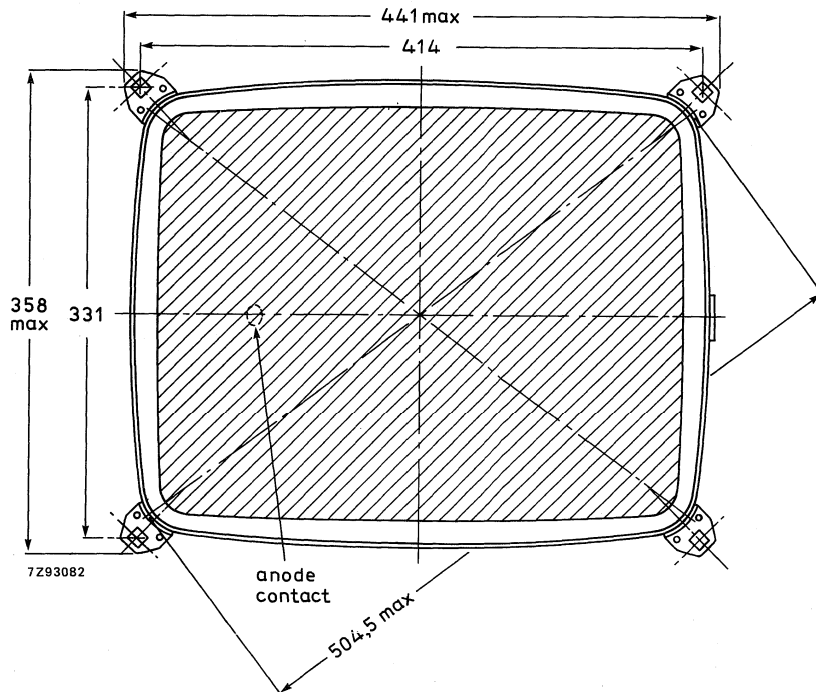

Fig. 16 Tube mounting dimensions; front view.

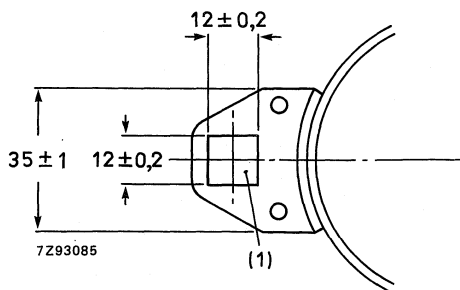

Fig. 17 Lug dimensions.

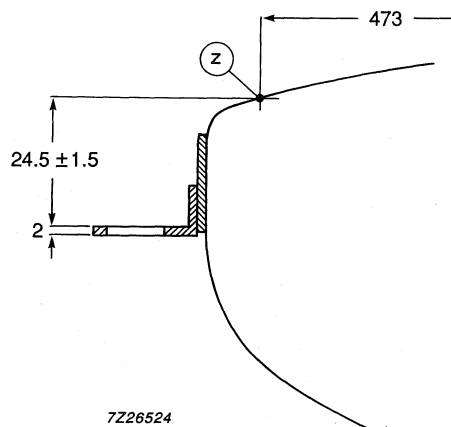

Fig. 18 Lug position.

(1) The mounting screws in the cabinet must be situated inside a circle of 8 mm diameter drawn around the true geometrical positions i.e. at the corners of a rectangle of 414 mm x 331 mm.

Maximum cone contour

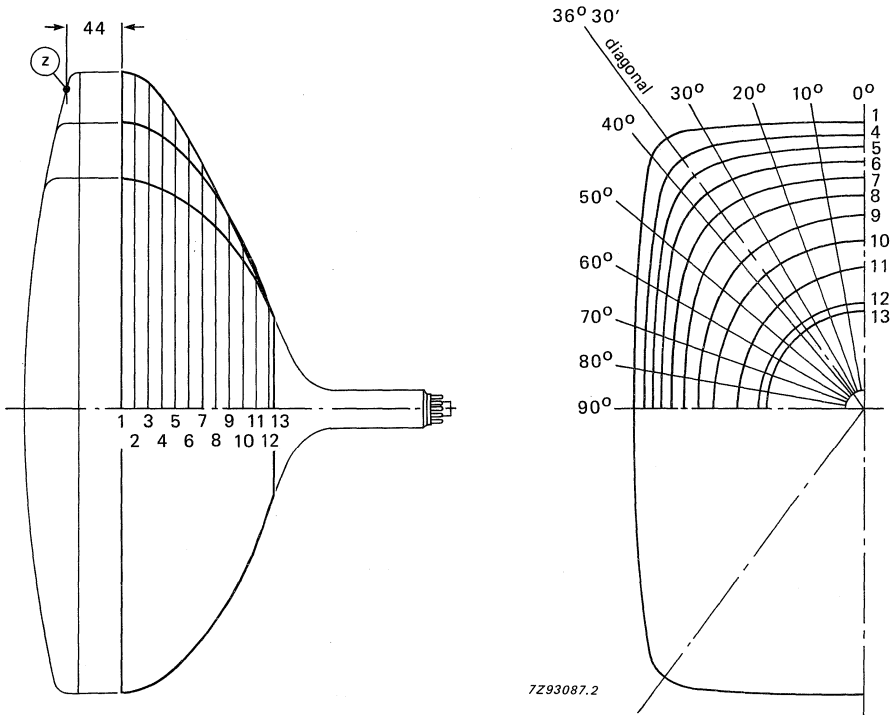

Fig. 19 Cone contour.

Table 1 Cone contour data

sec- tion	nom. distance from section 1	maximum distance from centre										
		0°	10°	20°	30°	diag.	40°	50°	60°	70°	80°	90°
1	0	212,40	215,27	224,24	240,47	250,00	246,96	215,59	193,30	179,48	171,91	169,50
2	10	211,37	214,23	223,15	239,25	249,13	246,39	215,32	192,88	179,00	171,41	168,99
3	20	208,00	210,74	219,25	234,40	244,05	241,65	212,73	190,50	176,69	169,13	166,73
4	30	203,99	206,43	213,93	226,89	233,79	230,99	207,33	186,52	173,13	165,75	163,40
5	40	198,33	200,43	206,81	217,05	220,83	218,32	199,70	181,12	168,49	161,41	159,14
6	50	190,32	192,10	197,40	204,53	205,72	203,55	189,36	173,85	162,55	156,00	153,87
7	60	179,54	181,01	185,01	188,72	187,90	185,85	175,57	163,90	154,70	149,06	147,16
8	70	165,75	166,89	169,39	170,43	168,81	167,08	159,85	151,68	144,83	140,38	138,80
9	80	147,99	148,83	150,23	150,21	148,78	147,54	142,72	137,24	132,45	129,19	127,97
10	90	124,88	125,48	126,40	126,58	126,02	125,48	123,25	120,47	117,83	115,89	115,12
11	100	101,31	100,91	99,98	98,75	97,88	97,42	96,16	95,12	94,37	93,97	93,88
12	110	74,28	74,01	73,54	73,02	72,70	72,54	72,18	71,97	71,92	72,00	72,11
13	113,36	64,18	64,12	64,01	63,89	63,82	63,78	63,70	63,66	63,65	63,68	63,71

DEVELOPMENT DATA

This data sheet contains advance information and specifications are subject to change without notice.

M51EAA

FLAT SQUARE HIGH RESOLUTION MONOCHROME MONITOR TUBE

- For Data Graphic Displays
- 110° deflection angle
- 51 cm (21 in) face diagonal; rectangular glass
- 28.6 mm neck diameter
- Integral implosion protection

QUICK REFERENCE DATA

Deflection angle	110°
Face diagonal	51 cm (21 in)
Overall length	max. 355 mm
Neck diameter	28.6 mm
Heating	6.3 V/240 mA
Quick heating cathode	with a typical tube a legible picture will appear within 5 s
Grid 2 voltage	700 V
Anode voltage	20 kV
Resolution	approx. 1400 lines

APPLICATION

This high resolution tube is for alphanumeric and graphic display applications, such as computer terminals, etc.

The tube can be supplied with different phosphors, see "High resolution monochrome monitor tubes, General".

ELECTRICAL DATA

Focusing method	electrostatic
Deflection method	magnetic
Deflection angles	
diagonal	approx. 110°
horizontal	approx. 95°
vertical	approx. 78°
Direct interelectrode capacitances	
cathode to all other electrodes	max. 5 pF
grid 1 to all other electrodes	max. 9 pF
Capacitance of external conductive coating to anode*	max. 2200 pF min. 1700 pF
Heater voltage	6.3 V
Heater current at 6.3 V	240 mA

OPTICAL DATA

Phosphor type	see "High resolution monochrome monitor tubes, General"
Light transmission at screen centre tube with dark tinted glass	approx. 34%

RASTER CENTRING

The field intensity perpendicular to the tube axis should be adjustable from 0 to 800 A/m. For optimum overall sharpness it is recommended to centre the raster electrically via the deflection coils.

TBF = to be finalised.

* Implosion protection hardware connected to external conductive coating.

MECHANICAL DATA (see also the figures under Dimensional Data)

Overall length	max. 355 mm
Greatest dimensions of tube	
diagonal	554.1 mm
width	461 mm
height	365 mm
Minimum useful screen dimensions (projected)	
diagonal	510.8 mm
horizontal axis	417.8 mm
vertical axis	320 mm
area	1304 cm ²
Implosion protection	rimband
Bulb	JB540AA03
Bulb contact designation	EIA J1-21
Base designation	IEC 67-1-31a; EIA B7-208
Basing	8 HR
Mass	approx. 13 kg

DEVELOPMENT DATA

RATINGS (Absolute Maximum System)

Unless otherwise specified voltage values are positive and measured with respect to grid 1.

Anode voltage	max. 23 kV min. 16 kV
Grid 4 (focusing electrode) voltage	-200 to +1000 V
Grid 2 voltage	min. 400 V max. 1000 V
Anode current	
long-term average value	max. 100 μ A
peak value	max. 300 μ A
Cathode voltage, positive peak value	max. 400 V
Heater voltage	6.3 V + 5/-10%*
Cathode-to-heater voltage	max. 150 V

* For maximum cathode life it is recommended that the heater supply be regulated at 6.3 V $\begin{matrix} +0\% \\ -5\% \end{matrix}$.

CIRCUIT DESIGN VALUES

Grid 4 current	
positive	max. 25 μ A
negative	max. 25 μ A
Grid 2 current	
positive	max. 5 μ A
negative	max. 5 μ A

MAXIMUM CIRCUIT VALUES

Resistance between cathode and heater	max. 1.0 M Ω
Impedance between cathode and heater	max. 0.1 M Ω
Grid 1 circuit resistance	max. 1.5 M Ω
Grid 1 circuit impedance	max. 0.5 M Ω

TYPICAL OPERATING CONDITIONS

Cathode drive; voltages specified with respect to grid 1

Anode voltage	20 kV
Grid 4 (focusing electrode) voltage	0 to 400 V*
Grid 2 voltage	700 V
Cathode cut-off voltage	72 to 112 V**

Grid drive; voltages specified with respect to cathode

Anode voltage	20 kV
Grid 4 (focusing electrode) voltage	0 to 400 V*
Grid 2 voltage	700 V
Grid 1 cut-off voltage	84 to 126 V**

RESOLUTION

The resolution is approx. 1400 lines. It is measured at the screen centre:

- with shrinking raster method,
- at light output 68.5 cd/m² (20 foot lambert) and raster dimensions 381 mm x 288 mm,
- at $V_{g2} = 700$ V and anode voltage = 20 kV,
- with phosphor type W (WW),
- with normal tinted face glass, without anti-glare treatment of screen surface.

X-RADIATION CHARACTERISTIC

X-radiation emitted will not exceed 0.5 mR/h throughout the useful life of the tube, when operated within the given ratings.

* Measured at screen centre on spot at anode current = 250 μ A (peak), anode voltage = 20 kV, grid 2 voltage = 700 V.

Dynamic focus (only for optimization): Typical correction for a video field of
H x V = 381 mm x 288 mm (landscape format): line parabola 300 V, field parabola 100 V.

** Visual extinction of focused raster.

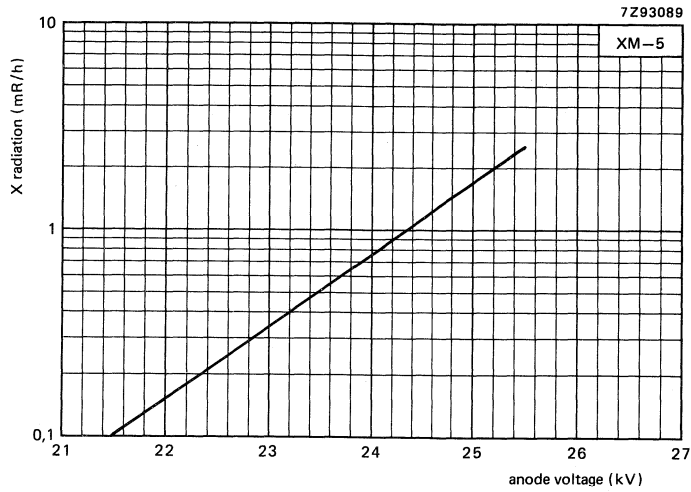

Fig. 1 X-radiation limit curve according to JEDEC 94, at a constant anode current of 250 μ A, measured according to TEPAC103A.

DEVELOPMENT DATA

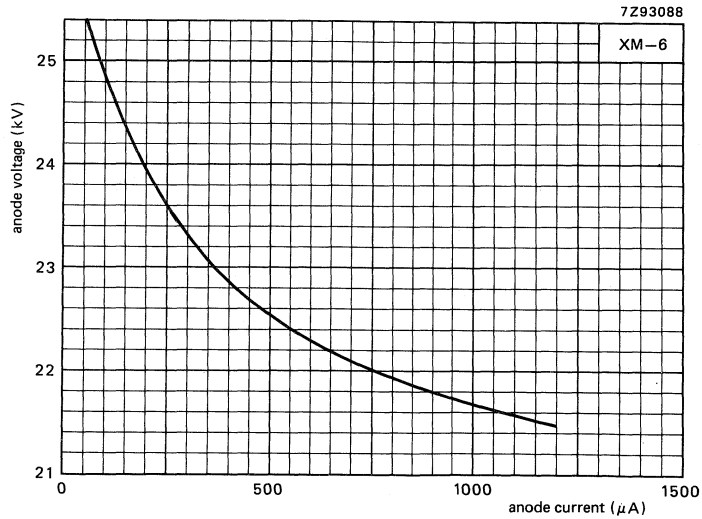

Fig. 2 0.5 mR/h isoexposure rate limit curve, according to JEDEC 94, measured according to TEPAX103A.

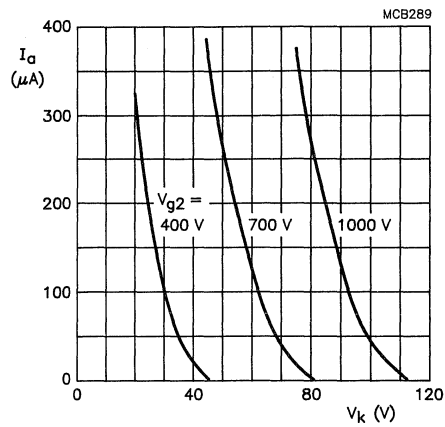

Fig. 3 Anode current as a function of cathode voltage.
Cathode drive; $V_{a,g3,g5} = 20$ kV.

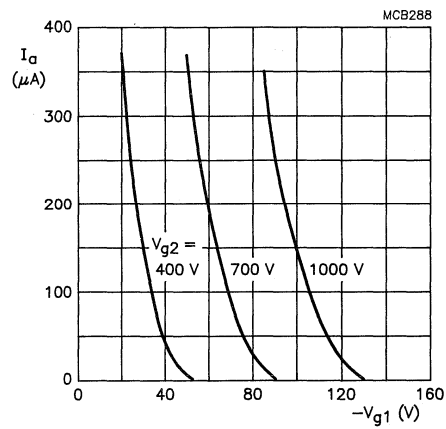

Fig. 4 Anode current as a function of grid 1 voltage.
Grid drive; $V_{a,g3,g5} = 20$ kV.

DEVELOPMENT DATA

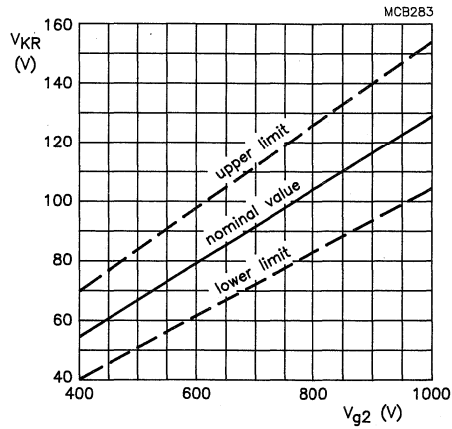

Fig. 5 Limits of cathode raster cut-off voltage as a function of grid 2 voltage. Cathode drive; $V_{a,g3,g5} = 20$ kV.

$$\frac{\Delta V_{KR}}{\Delta V_{a,g3,g5}} = 0,15 \times 10^{-3}$$

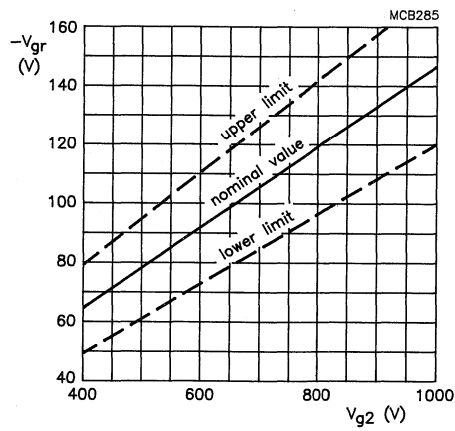
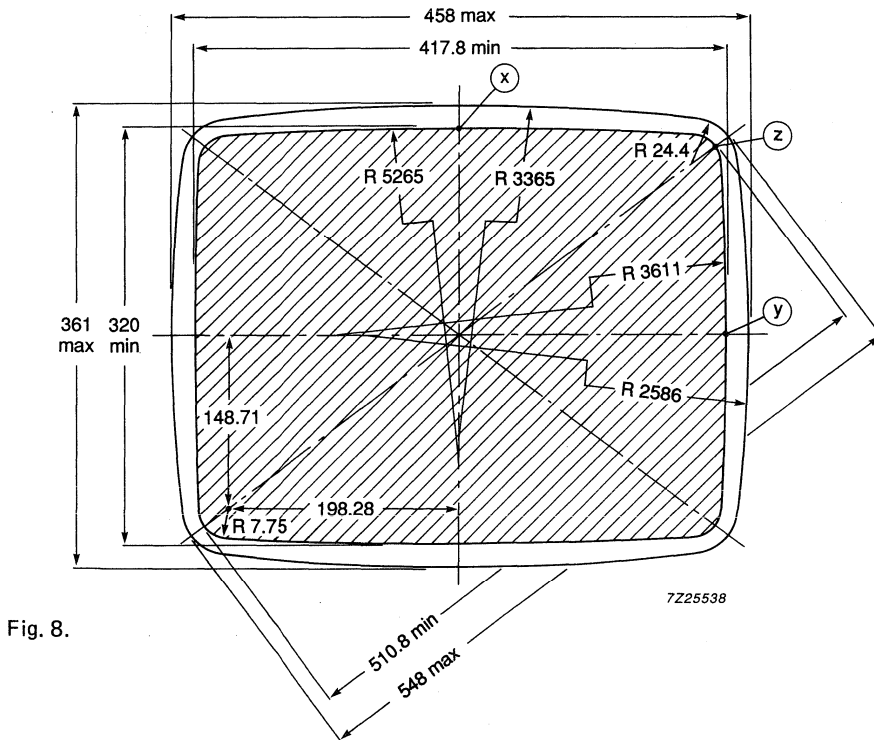
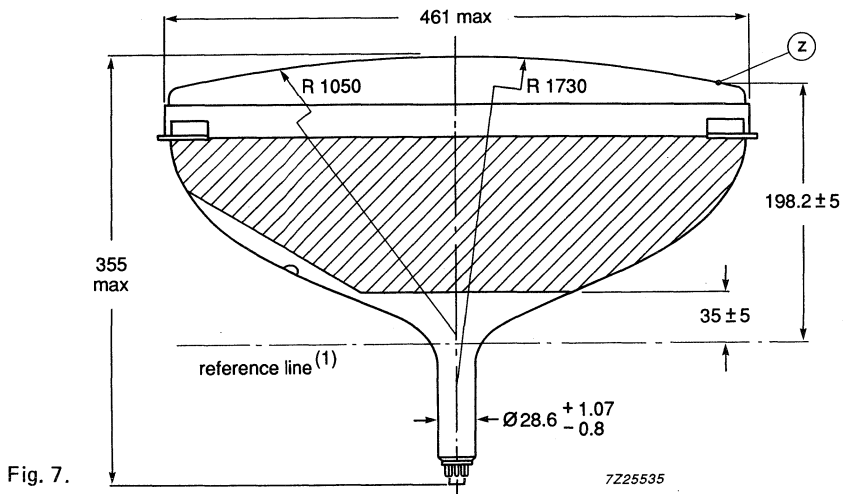

Fig. 6 Limits of grid 1 raster cut-off voltage as a function of grid 2 voltage. Grid drive; $V_{a,g3,g5} = 20$ kV.

$$\frac{\Delta V_{GR}}{\Delta V_{a,g3,g5}} = 0,15 \times 10^{-3}$$

DIMENSIONAL DATA



(1) The reference line is determined by the plane of the upper edge of reference line gauge C when the gauge is resting on the cone.

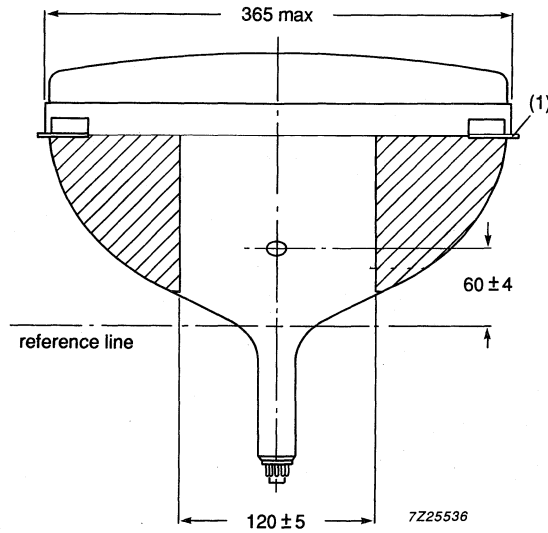

Fig. 9.

DEVELOPMENT DATA

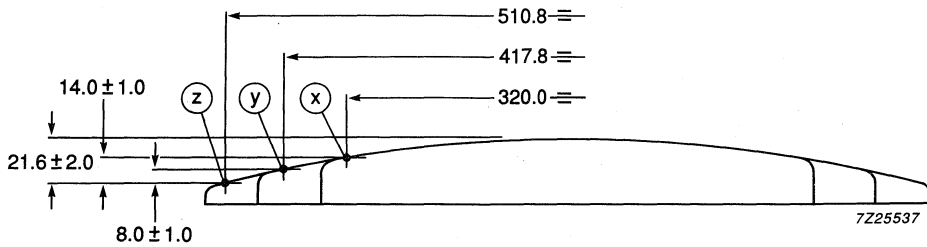

Fig. 10 Screen reference points.

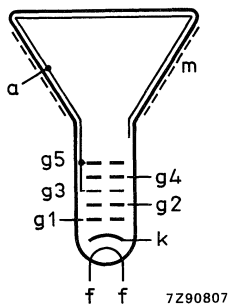

Fig. 11 Electrode configuration.

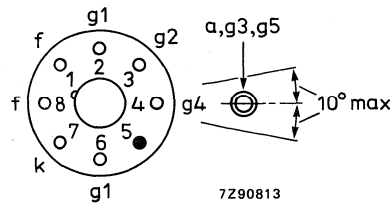

Fig. 12 Pin arrangement.

(1) The displacement of any lug with respect to the plane through the three other lugs is max. 1.5 mm.

Front view and lug dimensions

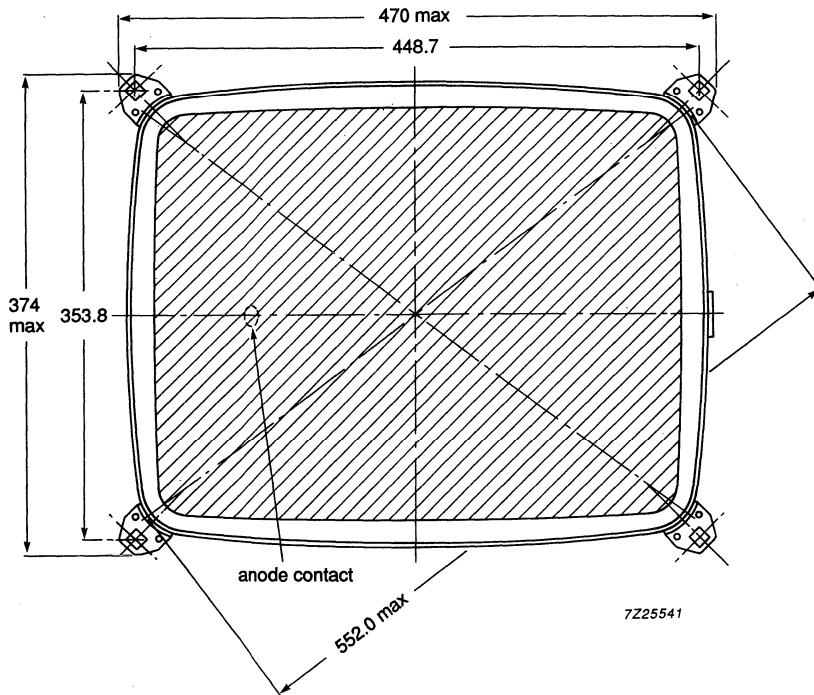

Fig. 13 Tube mounting dimensions; front view.

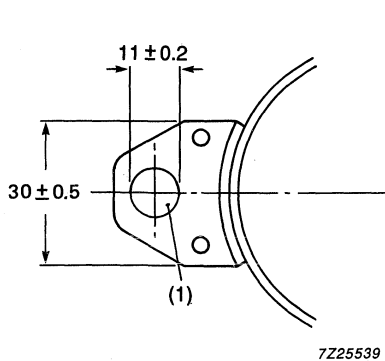

Fig. 14 Lug dimensions.

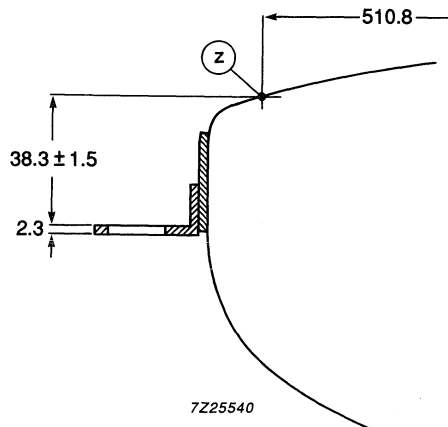

Fig. 15 Lug position.

(1) The mounting screws in the cabinet must be situated inside a circle of 6 mm diameter drawn around the true geometrical positions i.e. at the corners of a rectangle of 448.7 mm x 353.8 mm.

Maximum cone contour

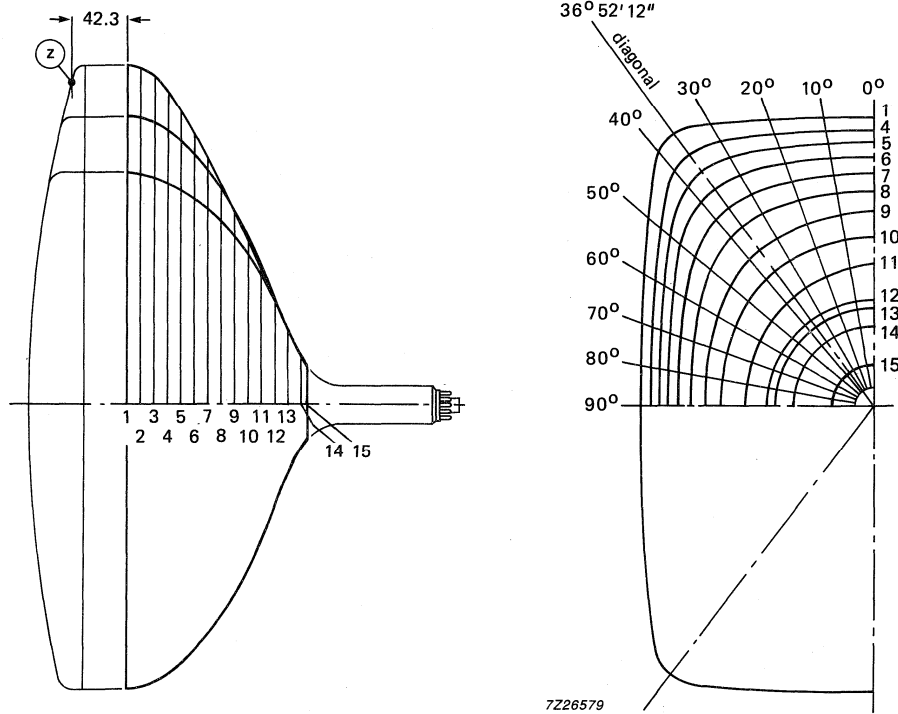

Fig. 16 Cone contour.

Table 1 Cone contour data

section	nom. distance from section 1	maximum distance from centre										
		0°	10°	20°	30°	diag.	40°	50°	60°	70°	80°	90°
1	0	226.75	229.65	239.65	257.65	272.00	267.00	228.64	204.32	189.40	181.27	178.69
2	10	226.35	229.15	239.15	257.15	271.30	266.30	227.80	203.82	188.90	180.77	178.19
3	20	225.85	228.63	238.51	256.49	270.30	265.76	227.40	203.32	187.15	180.27	177.59
4	30	221.81	224.39	233.81	250.84	263.65	259.60	223.17	199.84	185.40	177.57	175.02
5	40	216.35	218.55	226.16	241.03	251.67	248.25	216.32	195.20	181.59	174.46	172.00
6	50	208.79	210.43	216.66	227.53	235.63	232.99	207.01	188.80	177.12	170.54	168.30
7	60	199.65	200.68	205.34	213.23	218.93	215.80	196.33	181.26	171.23	165.63	163.66
8	70	188.87	189.56	192.63	197.70	201.47	199.95	184.27	172.36	163.86	159.56	157.89
9	80	175.86	176.56	178.17	181.05	183.30	182.18	170.71	161.99	155.45	152.20	150.82
10	90	160.38	160.66	161.50	162.87	164.03	163.28	155.61	149.92	145.72	142.74	142.18
11	100	142.07	142.18	142.61	143.22	143.66	143.14	138.86	135.92	133.62	132.18	131.38
12	110	121.18	121.79	121.87	122.00	122.08	121.79	120.15	119.50	118.73	118.24	117.42
13	120	98.79	98.70	98.71	98.79	98.79	98.79	98.65	98.71	98.66	98.65	98.23
14	130	73.95	73.95	73.95	73.95	73.95	73.95	73.95	73.95	73.95	73.95	73.95
15	145.6	41.15	41.15	41.15	41.15	41.15	41.15	41.15	41.15	41.15	41.15	41.15

DEFLECTION UNITS FOR
MONOCHROME MONITOR TUBES
ROTATION COIL

DEFLECTION UNIT

- For Data Graphic Displays
- For use with high resolution 47 cm (20 in) and 41 cm (17 in)/110° monochrome CRTs
- Optimized for minimum deflection defocusing
- Preset raster geometry for high resolution monitor tubes M47EAA and M41EAA
- Specially made for high line frequencies (up to 70 kHz)
- Electrical data given is for M47EAA

QUICK REFERENCE DATA

Deflection angle	110°
Neck diameter of CRT	28.6 mm
Screen diagonal of CRT	47/41 cm
Display format	landscape
Line deflection current for raster scan, at 17.5 kV	13.1 A _(p-p)
Inductance of line coils, parallel connected	72 μH
Field deflection current for raster scan, at 17.5 kV	0.87 A _(p-p)
Resistance of field coils, series connected	13.5 Ω

APPLICATION

This deflection unit is for Data Graphic Displays, especially when high resolution and/or high frequency operation is required. It is developed in conjunction with the high resolution monitor tube M47EAA to provide minimum deflection defocusing and good raster geometry without additional adjustments. Deflection unit AT1037/01 is for displays in horizontal (landscape, TV) format.

The AT1037/01 displays the same very high performance when used in conjunction with the M41EAA high resolution monitor tube.

To utilize the full potential of these deflection units in respect of deflection defocusing, dynamic focusing has to be applied in horizontal and vertical directions.

The line scan frequency is limited by the temperature of the deflection coils. The practical value depends on environmental conditions, but in general terms the highest operating frequency is approx. 70 kHz, thanks to the use of Litze wire in the line coils. At this line frequency the temperature rise of the deflection unit is less than 35° C, the maximum allowed average copper temperature of the unit is 95° C, hence, the environmental temperature must not exceed 60 °C. Where the circuitry and cabinet design are such that an operating environmental temperature of less than 60 °C is attained, the maximum permissible line frequency may be higher than the 70 kHz specified.

The following associated wound components are available for use in line time base circuits:

- AT2076/84 — universal line output transformer;
- AT4042/33A — linearity control unit (parallel connection);
- AT4042/08A — linearity control unit (series connection);
- AT4043/64 — line driver transformer;
- AT4043/29 — DC shift transformer;
- AT4044/35 — amplitude control unit.

A universal monitor design (C64L) has been developed, which is based on AT1037 deflection coils; it permits adjustment of the operating frequencies to the desired value by replacement of a few components only.

Further details are available on request.

DESCRIPTION

The line and field deflection coils are basically saddle-shaped and are surrounded by a Ferroxcube yoke ring. A special winding technique guarantees a precise magnetic field and a high reproducibility. Ferroxdure magnets are provided for beam centring. Provisions are made for mounting raster correction magnets.

The unit meets the self-extinguishing requirements of CSA, IEC and UL.

The top of the unit is marked.

MOUNTING

The unit should be mounted as far forward as possible on the neck of the tube so that it touches the cone; the maximum push-on force on the tube is 50 N.

To orient the raster correctly, the unit may be rotated by hand on the neck of the tube, with which it makes a slip fit. A screw-tightened clamping ring permits it to be locked, both axially and radially, in the desired position; the tightening torque is 0.75 to 0.90 Nm.

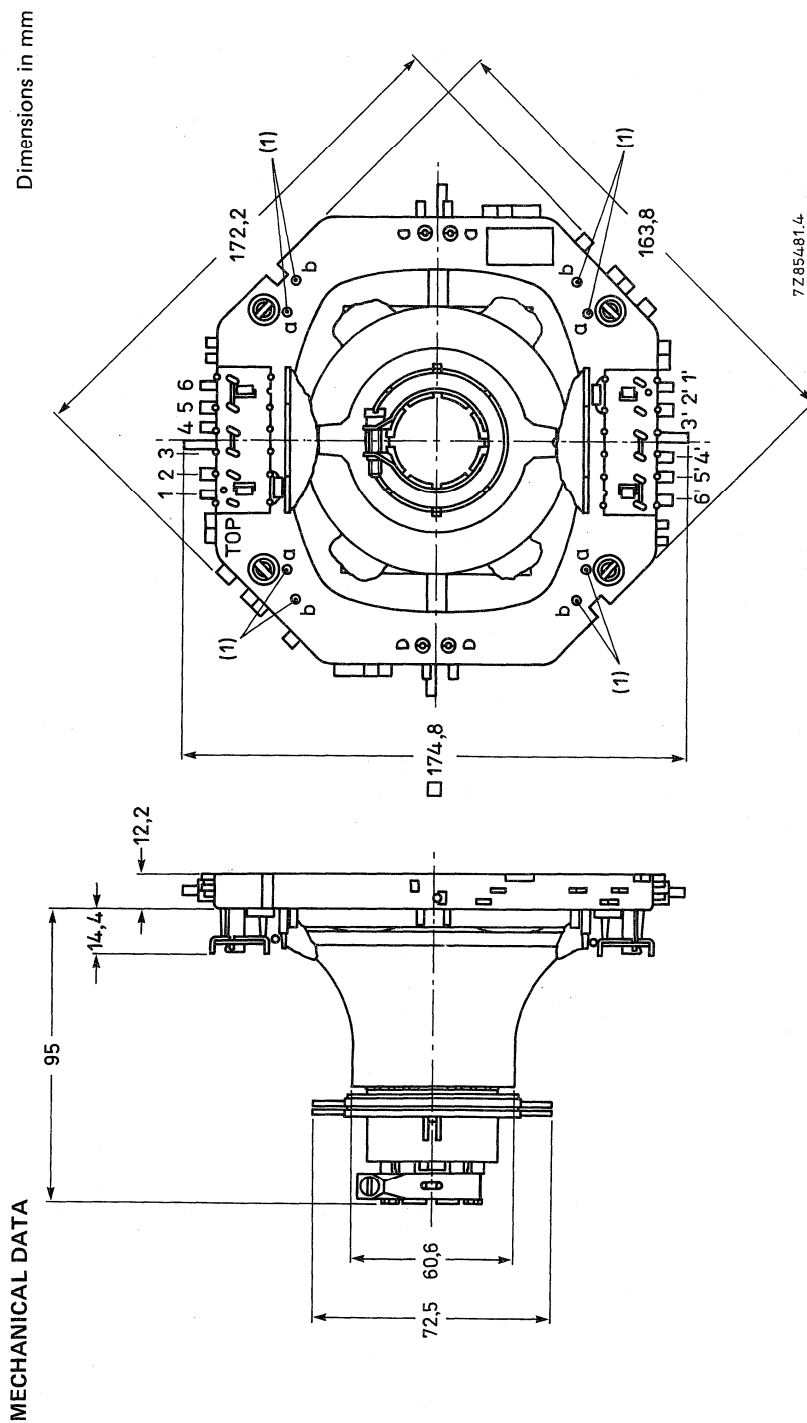

Fig. 1 Deflection unit AT1037/01.

If a further improvement of raster geometry is required use can be made of correction magnets*, which must be fitted to mounting posts (1). The unit has solder pins for connection. The pin numbering in Fig. 1 corresponds to that in Fig. 2.

* Catalogue number 3122 134 92300.

ELECTRICAL DATA

Line deflection coils

inductance
 resistance
 line deflection current for
 raster scan, at 17.5 kV
 raster scan

$72 \mu\text{H} \pm 5\%$
 $0.15 \Omega \pm 5\%$
 $13.1 \text{ A}_{(p-p)} \pm 5\%$
 348 mm

Field deflection coils

inductance
 resistance
 field deflection current for
 raster scan, at 17.5 kV
 raster scan

$12.2 \text{ mH} \pm 5\%$
 $13.5 \Omega \pm 5\%$
 $0.87 \text{ A}_{(p-p)} \pm 5\%$
 261 mm

Maximum permissible DC voltage between line and field coils

3000 V

Maximum permissible DC voltage between field coil and yoke ring

300 V

Coupling between line and field coils, at 1 V, 500 Hz

$\leq 1/100$

Note: The values apply at an ambient temperature of 23 °C

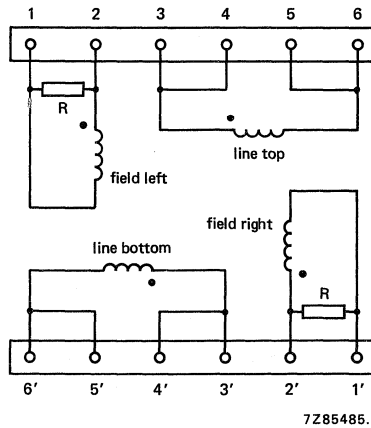

Fig. 2 Diagram of line and field coils; R = 270 Ω. The beginning of the windings is indicated with •.

ENVIRONMENTAL DATA

Maximum operating temperature (average copper temperature)	95 °C
Maximum possible temperature rise (ΔT) as a result of coil losses at 70 kHz	35 °C
Storage temperature range	-25 to + 95 °C
Flame retarding	according to UL1413
Flammability	according to UL94, category V1

ENVIRONMENTAL TESTS

The deflection units withstand the following tests:

Vibration	IEC 68-2-6; test Fc, procedure B4; 10-55-10 Hz, amplitude 0.35 mm, 3 x 30 min.
Bump	IEC 68-2-29, test Eb; 250 m/s ² , 1000 bumps, 6 directions.
Shock	IEC 68-2-27, test Ea; 11 ms, half-sine pulse shape, 350 m/s ² , 3 x 6 directions.
Cold	IEC 68-2-1, test Ab; 96 h, -25 °C.
Dry heat	IEC 68-2-2, test Bb; 96 h, + 95 °C.
Cyclic damp heat	IEC 68-2-30, test Db; 21 cycles, + 40 °C.
Damp heat, steady state	IEC 68-2-3, test Ca, 21 days.
Change of temperature	IEC 68-2-14, test Nb; 5 cycles of 2 h at -25 °C and 2 h at + 95 °C, duration of one cycle 5 h.

BEAM CENTRING

The deflection units have two independently movable centring magnets of plastic-bonded Ferroxdure. These magnets are for placing the electron beam coaxially with the deflection coils. They are magnetized diametrically. By turning the magnets with respect to each other the resulting field strength is varied. The direction of the resulting magnetic field is adjusted by turning the magnets simultaneously. The required torque on the magnets is 35 to 250 mNm. See also Fig. 5.

The correct position of the magnets ensures freedom from curved lines in the centre of the raster and is beneficial with regard to raster geometry, deflection defocusing, corner cutting etc. For quality performance, picture shift should be obtained by applying d.c. current through the deflection coils.

This should be done after adjustment of raster linearity and after correct phasing of displayed information in respect of the raster.

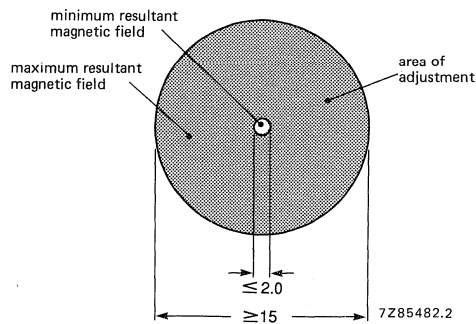

Fig. 5.

PACKING

The deflection units are packed on pallets of 10 or 15 boxes. Each box contains 24 deflection units.

DEFLECTION UNITS

- For Data Graphic Displays
- For use with high resolution 38 cm (15 in)/110° monochrome CRTs
- Optimized for minimum deflection defocusing
- Preset raster geometry for high resolution monitor tube M38-328
- Separate types for landscape and portrait formats

QUICK REFERENCE DATA

	AT1039/00	AT1039/01
Deflection angle	110°	110°
Neck diameter of CRT	28.6 mm	28.6 mm
Screen diagonal of CRT	38 cm	38 cm
Display format	portrait	landscape
Line deflection current for raster scan, at 17 kV	5.60 A _(p-p)	7.55 A _(p-p)
Inductance of line coils, parallel connected	225 μH	206 μH
Field deflection current for raster scan, at 17 kV	1.15 A _(p-p)	0.90 A _(p-p)
Resistance of field coils, series connected	10.2 Ω	10.5 Ω

APPLICATION

These deflection units are for Data Graphic Displays, especially when high resolution and/or high frequency operation is required. They are developed in conjunction with the high resolution monitor tube M38-328 to provide minimum deflection defocusing and good raster geometry without additional adjustments. Deflection unit AT1039/00 is for displays in vertical (portrait) format, AT1039/01 for displays in horizontal (landscape, TV) format.

To utilize the full potential of these deflection units in respect of deflection defocusing, dynamic focusing has to be applied in horizontal and vertical directions.

The line scan frequency is limited by the temperature of the deflection coils. The practical value depends on environmental conditions, but in general terms the highest operating frequency is approx. 50 kHz in landscape format and approx. 70 kHz in portrait format. At this line frequency the temperature rise of the deflection unit is less than 35 °C, the maximum allowed average copper temperature of the unit is 95 °C, hence, the environmental temperature must not exceed 60 °C. Where the circuitry and cabinet design are such that an operating environmental temperature of less than 60 °C is attained, the maximum permissible line frequency may be higher than the 50 kHz/70 kHz specified.

To provide some choice of impedances, the termination of the coils are brought out permitting either series or parallel connections.

When the coils are connected in parallel it is possible to provide scan at the highest frequency using existing devices. The impedance of the field coils (series connected) is adjusted for operation with integrated circuits (e.g. TDA2653A).

The following associated wound components are available for use in line time base circuits:

- AT2076/84 – universal line output transformer;
- AT4042/33A – linearity control unit (parallel connection);
- AT4042/08A – linearity control unit (series connection);
- AT4043/64 – line driver transformer;
- AT4043/29 – d.c. shift transformer;
- AT4044/35 – amplitude control unit.

A universal monitor design (C64) has been developed, which is based on AT1039 deflection coils; it permits adjustment of the operating frequencies to the desired value by replacement of a few components only.

Further details are available on request.

DESCRIPTION

The line and field deflection coils are basically saddle-shaped and are surrounded by a Ferroxcube yoke ring. A special winding technique guarantees a precise magnetic field and a high reproducibility. Ferroxdure magnets are provided for beam centring. Provisions are made for mounting raster correction magnets.

The units meet the self-extinguishing requirements of CSA, IEC and UL.

The top of the units is marked.

MOUNTING

The unit should be mounted as far forward as possible on the neck of the tube so that it touches the cone; the maximum push-on force on the tube is 50 N.

To orient the raster correctly, the unit may be rotated by hand on the neck of the tube, with which it makes a slip fit. A screw-tightened clamping ring permits it to be locked, both axially and radially, in the desired position; the tightening torque is 0,75 to 0,90 Nm.

Dimensions in mm

MECHANICAL DATA

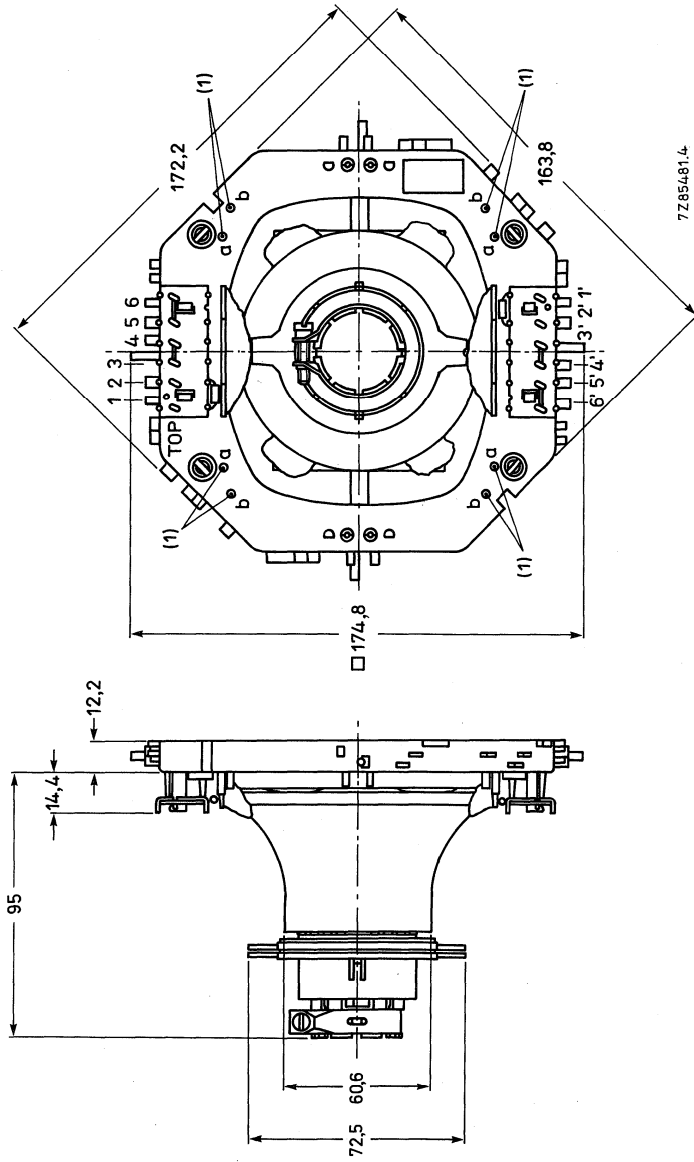

Fig. 1 Deflection units AT1039/00 and AT1039/01.

If a further improvement of raster geometry is required use can be made of correction magnets*, which must be fitted to mounting posts (1); posts a to be used for AT1039/00, posts b for AT1039/01. The unit has solder pins for connection. The pin numbering in Fig. 1 corresponds to that in Fig. 2.

* Catalogue number 3122 134 92300.

ELECTRICAL DATA

	AT1039/00		AT1039/01	
	parallel connected	series connected	parallel connected	series connected
Line deflection coils				
inductance	225 $\mu\text{H} \pm 5\%$	900 $\mu\text{H} \pm 5\%$	206 $\mu\text{H} \pm 5\%$	824 $\mu\text{H} \pm 5\%$
resistance	0.39 $\Omega \pm 5\%$	1.56 $\Omega \pm 5\%$	0.38 $\Omega \pm 5\%$	1.52 $\Omega \pm 5\%$
line deflection current, for raster scan, at 17 kV raster scan	5.60 A _(p-p) $\pm 5\%$ 194 mm	2.80 A _(p-p) $\pm 5\%$ 194 mm	7.55 A _(p-p) $\pm 5\%$ 259 mm	3.78 A _(p-p) $\pm 5\%$ 259 mm
Field deflection coils				
inductance	2.30 mH $\pm 5\%$	9.18 mH $\pm 5\%$	2.40 mH $\pm 5\%$	9.60 mH $\pm 5\%$
resistance	2.55 $\Omega \pm 5\%$	10.2 $\Omega \pm 5\%$	2.63 $\Omega \pm 5\%$	10.5 $\Omega \pm 5\%$
field deflection current, for raster scan, at 17 kV raster scan	2.30 A _(p-p) $\pm 5\%$ 259 mm	1.15 A _(p-p) $\pm 5\%$ 259 mm	1.8 A _(p-p) $\pm 5\%$ 194 mm	0.90 A _(p-p) $\pm 5\%$ 194 mm

Maximum permissible DC voltage between line and field coils 3000 V
 Maximum permissible DC voltage between field coil and yoke ring 300 V
 Coupling between line and field coils, at 1 V, 500 Hz $\leq 1/100$

Note: The values apply at an ambient temperature of 23 °C.

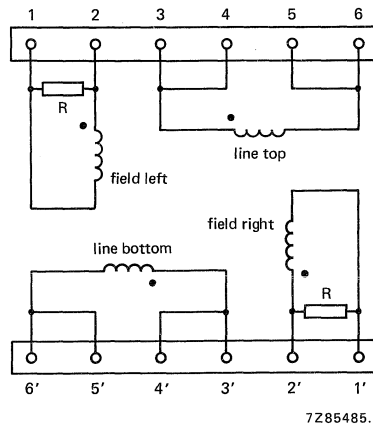

Fig. 2 Diagram of line and field coils; R = 270 Ω . The beginning of the windings is indicated with ●.

Interconnections

	terminals to be interconnected	output terminals*	
		live	neutral
<u>Line deflection coils</u>			
parallel connection	3, 4 to <u>5'</u> , <u>6'</u> and 3', 4' to 5, 6	<u>3, 4</u> <u>5', 6'</u>	<u>3', 4'</u> , 5, 6
series connection	3, 4 to 3', 4'	<u>5', 6'</u>	<u>5, 6</u>
<u>Field deflection coils</u>			
parallel connection	1 to 2' and 1' to 2	<u>1', 2</u>	1, <u>2'</u>
series connection	2 to 2'	<u>1'</u>	<u>1</u>

Geometric distortion, without raster correction and centring magnets.

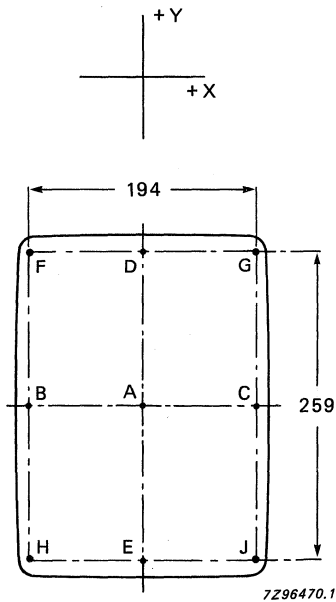

Fig. 3a AT1039/00.

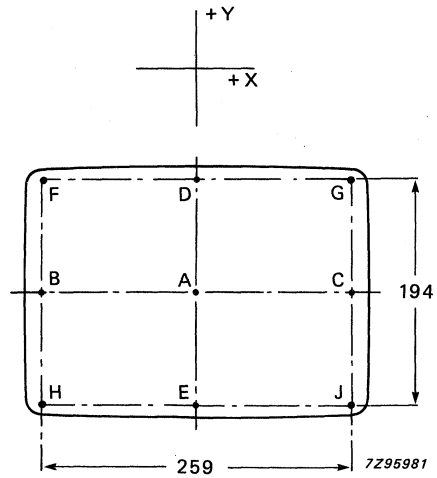

Fig. 3b AT1039/01.

* Terminals which are most convenient to be used as output terminals are underlined.

ENVIRONMENTAL DATA

Maximum operating temperature (average copper temperature)	95 °C
Maximum possible temperature rise (ΔT) as a result of coil losses at 50 kHz and 70 kHz respectively	35 °C
Storage temperature range	-25 to + 95 °C
Flame retarding	according to UL1413
Flammability	according to UL94, category V1

ENVIRONMENTAL TESTS

The deflection units withstand the following tests:

Vibration	IEC 68-2-6; test Fc, procedure B4; 10-55-10 Hz, amplitude 0.35 mm, 3 x 30 min.
Bump	IEC 68-2-29, test Eb; 250 m/s ² , 1000 bumps, 6 directions.
Shock	IEC 68-2-27, test Ea; 11 ms, half-sine pulse shape, 350 m/s ² , 3 x 6 directions.
Cold	IEC 68-2-1, test Ab; 96 h, -25 °C.
Dry heat	IEC 68-2-2, test Bb; 96 h, + 95 °C.
Cyclic damp heat	IEC 68-2-30, test Db; 21 cycles, + 40 °C.
Damp heat, steady state	IEC 68-2-3, test Ca, 21 days.
Change of temperature	IEC 68-2-14, test Nb; 5 cycles of 2 h at -25 °C and 2 h at + 95 °C, duration of one cycle 5 h.

BEAM CENTRING

The deflection units have two independently movable centring magnets of plastic-bonded Ferroxdure. These magnets are for placing the electron beam coaxially with the deflection coils. They are magnetized diametrically. By turning the magnets with respect to each other the resulting field strength is varied. The direction of the resulting magnetic field is adjusted by turning the magnets simultaneously. The required torque on the magnets is 35 to 250 mNm. See also Fig. 5.

The correct position of the magnets ensures freedom from curved lines in the centre of the raster and is beneficial with regard to raster geometry, deflection defocusing, corner cutting etc. For quality performance, picture shift should be obtained by applying d.c. current through the deflection coils.

This should be done after adjustment of raster linearity and after correct phasing of displayed information in respect of the raster.

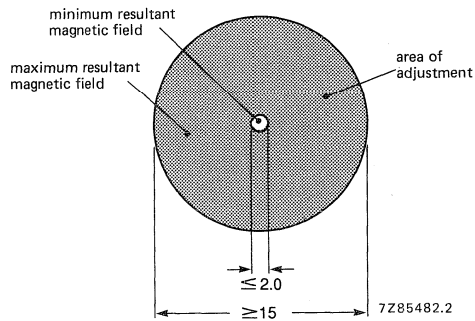

Fig. 5.

PACKING

The deflection units are packed on pallets of 10 or 15 boxes. Each box contains 24 deflection units.

DEFLECTION UNIT

- For Data Graphic Displays
- For use with high resolution 31 cm (12 in)/110° monochrome CRTs
- Optimized for minimum deflection defocusing
- Preset raster geometry for high resolution monitor tube M31-326

QUICK REFERENCE DATA

Deflection angle	110°
Neck diameter of CRT	28.6 mm
Screen diagonal of CRT	31 cm
Display format	landscape
Line deflection current for full scan, at 17 kV	7.34 A (p-p)
Inductance of line coils, parallel connected	228.5 μ H
Field deflection current for full scan, at 17 kV	1.03 A (p-p)
Resistance of field coils, series connected	10.2 Ω

APPLICATION

This deflection unit is for Data Graphic Displays, especially when high resolution and/or high frequency operation is required. It is developed in conjunction with the high resolution monitor tube M31-326 to provide minimum deflection defocusing and good raster geometry without additional adjustments.

Deflection unit AT1039/03 is for display in horizontal (landscape, TV) format.

To utilize the full potential of this deflection unit in respect of deflection defocusing, dynamic focusing has to be applied in horizontal and vertical directions.

The line scan frequency is limited by the temperature of the deflection coils. The practical value depends on environmental conditions, but in general terms the highest operating frequency is approx. 50 kHz. At this line frequency the temperature rise of the deflection unit is less than 35 °C, the maximum allowed average copper temperature of the unit is 95 °C, hence, the environmental temperature must not exceed 60 °C. Where the circuitry and cabinet design are such that an operating environmental temperature of less than 60 °C is attained, the maximum permissible line frequency may be higher than the 50 kHz specified.

The following associated wound components are available for use in line time base circuits:

- AT2076/84 — universal line output transformer;
- AT4042/33A — linearity control unit (parallel connection);
- AT4042/08A — linearity control unit (series connection);
- AT4043/64 — line driver transformer;
- AT4043/29 — DC shift transformer;
- AT4044/35 — amplitude control unit.

A universal monitor design (C64) has been developed, which is based on AT1039 deflection coils; it permits adjustment of the operating frequencies to the desired value by replacement of a few components only.

Further details are available on request.

DESCRIPTION

The line and field deflection coils are basically saddle-shaped and are surrounded by a ferroxcube yoke ring. A special winding technique guarantees a precise magnetic field and a high reproducibility. Ferroxdure magnets are provided for beam centring. Provisions are made for mounting raster correction magnets.

The unit meets the self-extinguishing requirements of CSA, IEC and UL.

The top of the unit is marked.

MOUNTING

The unit should be mounted as far forward as possible on the neck of the tube so that it touches the cone; the maximum push-on force on the tube is 50 N.

To orient the raster correctly, the unit may be rotated by hand on the neck of the tube, with which it makes a slip fit. A screw-tightened clamping ring permits it to be locked, both axially and radially, in the desired position; the tightening torque is 0.75 to 0.90 Nm.

MECHANICAL DATA

Dimensions in mm

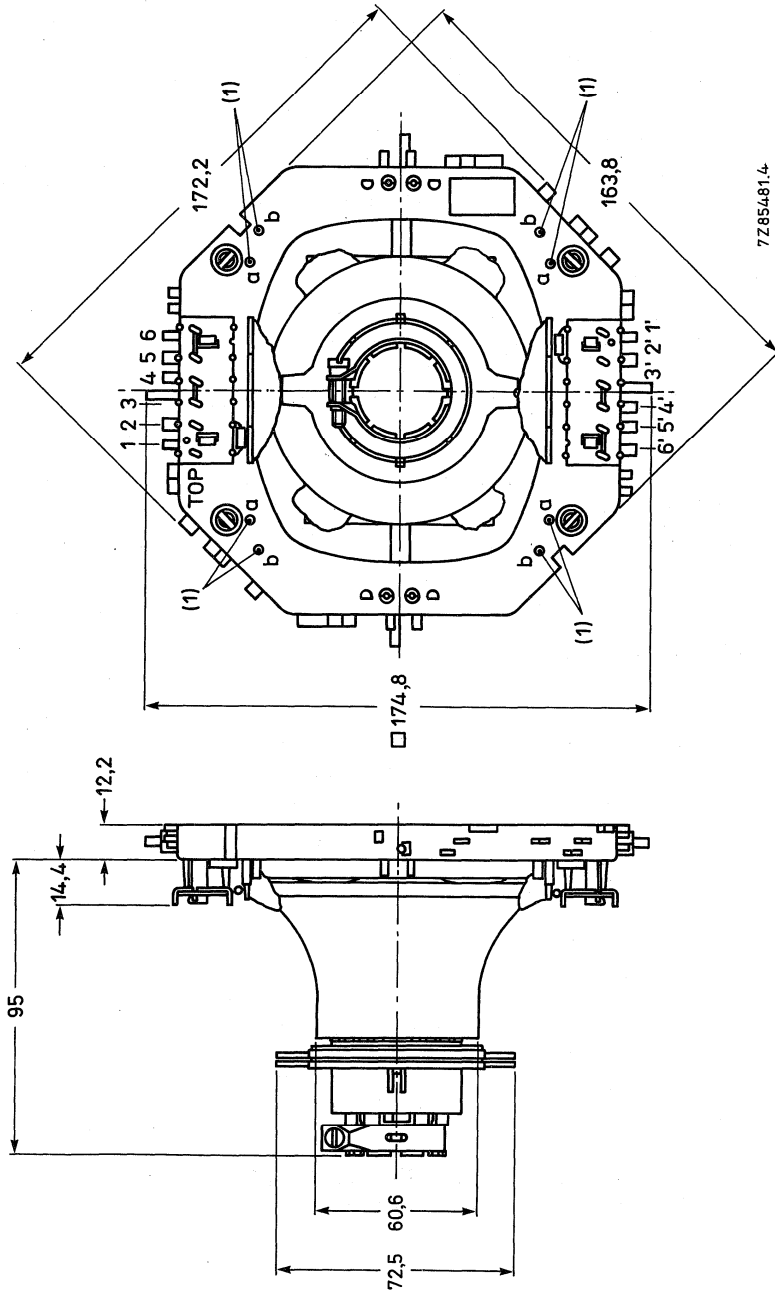

Fig.1 Deflection unit AT1039/03.

If a further improvement of raster geometry is required use can be made of correction magnets*, which must be fitted to mounting posts (1). The unit has solder pins for connection. The pin numbering in Fig.1 corresponds to that in Fig.2.

* Catalogue number 3122 134 92300. Six magnets are included in the packing of the deflection unit.

ELECTRICAL DATA

	parallel connected	series connected
Line deflection coils		
inductance	228.5 $\mu\text{H} \pm 5\%$	914 $\mu\text{H} \pm 5\%$
resistance	0.41 $\Omega \pm 5\%$	1.64 $\Omega \pm 5\%$
line deflection current, for raster scan, at 17 kV raster scan	7.34 A (p-p) $\pm 5\%$ 230 mm	3.67 A (p-p) $\pm 5\%$ 230 mm
Field deflection coils		
inductance	2.30 mH $\pm 5\%$	9.18 mH $\pm 5\%$
resistance	2.55 $\Omega \pm 5\%$	10.2 $\Omega \pm 5\%$
field deflection current, for raster scan, at 17 kV raster scan	2.06 A (p-p) $\pm 5\%$ 170 mm	1.03 A (p-p) $\pm 5\%$ 170 mm

Maximum permissible DC voltage between line and field coils

3000 V

Maximum permissible DC voltage between field coil and yoke ring

300 V

Coupling between line and field coils, at 1 V, 500 Hz

$\leq 1/100$

Note: The values apply at an ambient temperature of 23 °C.

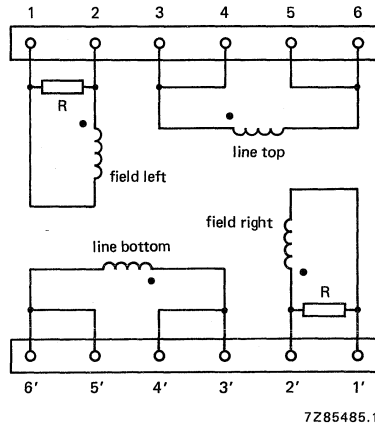

Fig. 2 Diagram of line and field coils; R = 270 Ω . The beginning of the windings is indicated with ●.

Interconnections

	terminals to be interconnected	output terminals*	
		live	neutral
Line deflection coils			
parallel connected	3, 4 to 5', 6' and 3', 4' to 5, 6	<u>3</u> , <u>4</u> , <u>5'</u> , <u>6'</u>	<u>3'</u> , <u>4'</u> , <u>5</u> , <u>6</u>
series connection	3, 4 to 3', 4'	<u>5'</u> , <u>6'</u>	<u>5</u> , <u>6</u>
Field deflection coils			
parallel connected	1 to 2' and 1' to 2	<u>1'</u> , <u>2</u>	<u>1</u> , <u>2'</u>
series connection	2 to 2'	<u>1'</u>	<u>1</u>

* Terminals which are most convenient to be used as output terminals are underlined.

Geometric distortion, without raster correction and centring magnets.

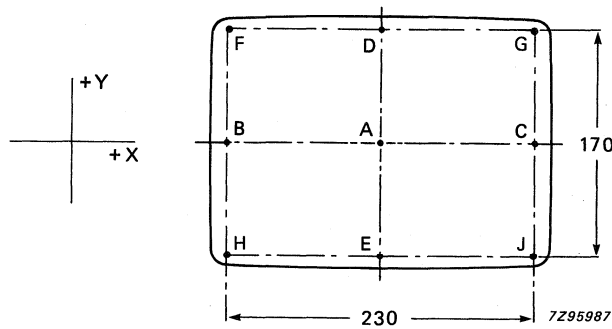

Fig. 3 Raster scan.

Obliquity

- $|Fy - Gy| \leq 3.5 \text{ mm}$
- $|Gx - Jx| \leq 3.5 \text{ mm}$
- $|Jy - Hy| \leq 3.5 \text{ mm}$
- $|Hx - Fx| \leq 3.5 \text{ mm}$
- $|Dx| \text{ and } |Ex| \leq 0.8 \text{ mm}$
- $|By| \text{ and } |Cy| \leq 0.5 \text{ mm}$

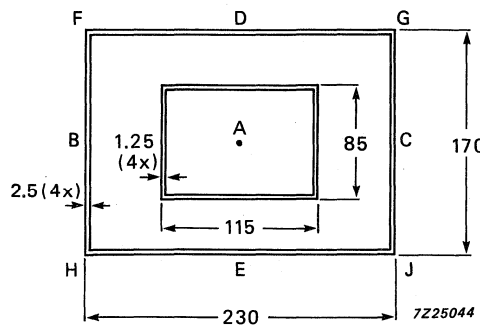

Fig. 4 Obliquity.

Note: The edges of the displayed raster should fall within the two rectangles.

Spot quality and measurement (refer to Fig. 3)

To be measured in accordance with TVV55-84-0002.

Mean spot dimension is related to the spot at point A.

$$\text{Mean spot size} = \frac{l + s}{2}$$

Where: l = longest spot axis
 s = shortest spot axis

Measuring conditions:

V_{ht} = 17 kV
 V_{g2} = 700 V
 I_a = 100 μ A

The following values for spot growth are defined with DC-deflection and optimal focus voltage V_{g4} per measuring point:

spot size B and C = spot size A + 15% \pm 20%

spot size D and E = spot size A + 15% \pm 20%

spot size F, G, H and J = spot size A + 25% \pm 20%

ENVIRONMENTAL DATA

Maximum operating temperature (average copper temperature)	95 °C
Maximum possible temperature rise (ΔT) as a result of coil losses, at 50 kHz	35 °C
Storage temperature range	-25 to + 95 °C
Flame retarding	according to UL1413
Flammability	according to UL94, category V1

ENVIRONMENTAL TESTS

The deflection units withstand the following tests:

Vibration	IEC 68-2-6; test Fc, procedure B4; 10-55-10 Hz, amplitude 0.35 mm, 3 x 30 min.
Bump	IEC 68-2-29, test Eb; 250 m/s ² , 1000 bumps, 6 directions.
Shock	IEC 68-2-27, test Ea; 11 ms, half-sine pulse shape, 350 m/s ² , 3 x 6 directions.
Cold	IEC 68-2-1, test Ab; 96 h, -25 °C.
Dry heat	IEC 68-2-2, test Bb; 96 h, + 95 °C.
Cyclic damp heat	IEC 68-2-30, test Db; 21 cycles, + 40 °C.
Damp heat, steady state	IEC 68-2-3, test Ca, 21 days.
Change of temperature	IEC 68-2-14, test Nb; 5 cycles of 2 h at -25 °C and 2 h at + 95 °C, duration of one cycle 5 h.

BEAM CENTRING

The deflection unit has two independently movable centring magnets of plastic-bonded Ferroxdure. These magnets are for placing the electron beam coaxially with the deflection coils. They are magnetized diametrically. By turning the magnets with respect to each other the resulting field strength is varied. The direction of the resulting magnetic field is adjusted by turning the magnets simultaneously. The required torque on the magnets is 35 to 250 mNm. See also Fig. 5.

The correct position of the magnets ensures freedom from curved lines in the centre of the raster and is beneficial with regard to raster geometry, deflection defocusing, corner cutting etc. For quality performance, picture shift should be obtained by applying d.c. current through the deflection coils. This should be done after adjustment of raster linearity and after correct phasing of displayed information in respect of the raster.

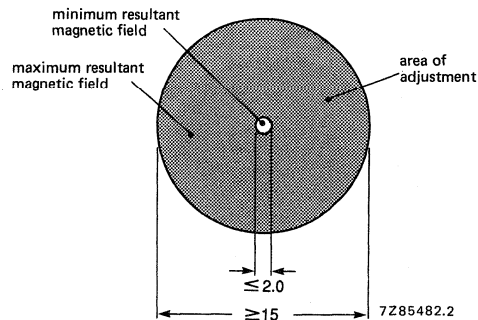

Fig. 5.

PACKING

The deflection units are packed on pallets of 10 or 15 boxes. Each box contains 24 deflection units.

DEVELOPMENT DATA

This data sheet contains advance information and specifications are subject to change without notice.

AT1039/05

DEFLECTION UNIT

- For Data Graphic Displays
- For use with high resolution 38 cm (15 in)/110° monochrome CRTs
- Optimized for minimum deflection defocusing
- Preset raster geometry for high resolution monitor tube M38-328

QUICK REFERENCE DATA

Deflection angle	110°
Neck diameter of CRT	28.6 mm
Screen diagonal of CRT	38 cm
Display format	landscape
Line deflection current for raster scan, at 17 kV	10.5 A (p-p)
Inductance of line coils, parallel connected	107.5 μ H
Field deflection current for raster scan, at 17 kV	0.95 A (p-p)
Resistance of field coils, series connected	10.4 Ω

APPLICATION

This deflection unit is for Data Graphic Displays, especially when high resolution and/or high frequency operation is required. It is developed in conjunction with the high resolution monitor tube M38-328 to provide minimum deflection defocusing and good raster geometry without additional adjustments. Deflection unit AT1039/05 is for display in horizontal (landscape, TV) format.

To utilize the full potential of these deflection units in respect of deflection defocusing, dynamic focusing has to be applied in horizontal and vertical directions.

The line scan frequency is limited by the temperature of the deflection coils. The practical value depends on environmental conditions, but in general terms the highest operating frequency is approx. 50 kHz, thanks to the use of Litz wire in the line coils. At this line frequency the temperature rise of the deflection unit is less than 35° C, the maximum allowed average copper temperature of the unit is 95° C, hence, the environmental temperature must not exceed 60 °C. Where the circuitry and cabinet design are such that an operating environmental temperature of less than 60 °C is attained, the maximum permissible line frequency may be higher than the 50 kHz specified.

To provide some choice of impedances, the terminations of the coils are brought out permitting either series or parallel connections.

When the coils are connected in parallel it is possible to provide scan at the highest frequency using existing devices. The impedance of the field coils (series connected) is adjusted for operation with integrated circuits (e.g. TDA2653A).

The following associated wound components are available for use in line time base circuits:

- AT2076/84 — universal line output transformer;
- AT4042/33A — linearity control unit (parallel connection);
- AT4042/08A — linearity control unit (series connection);
- AT4043/64 — line driver transformer;
- AT4043/29 — DC shift transformer;
- AT4044/35 — amplitude control unit.

A universal monitor design (C64) has been developed, which is based on AT1039 deflection coils; it permits adjustment of the operating frequencies to the desired value by replacement of a few components only.

Further details are available on request.

DESCRIPTION

The line and field deflection coils are basically saddle-shaped and are surrounded by a Ferroxcube yoke ring. A special winding technique guarantees a precise magnetic field and a high reproducibility. Ferroxdure magnets are provided for beam centring. Provisions are made for mounting raster correction magnets.

The unit meets the self-extinguishing requirements of CSA, IEC and UL.

The top of the unit is marked.

MOUNTING

The unit should be mounted as far forward as possible on the neck of the tube so that it touches the cone; the maximum push-on force on the tube is 50 N.

To orient the raster correctly, the unit may be rotated by hand on the neck of the tube, with which it makes a slip fit. A screw-tightened clamping ring permits it to be locked, both axially and radially, in the desired position; the tightening torque is 0.75 to 0.90 Nm.

DEVELOPMENT DATA

Dimensions in mm

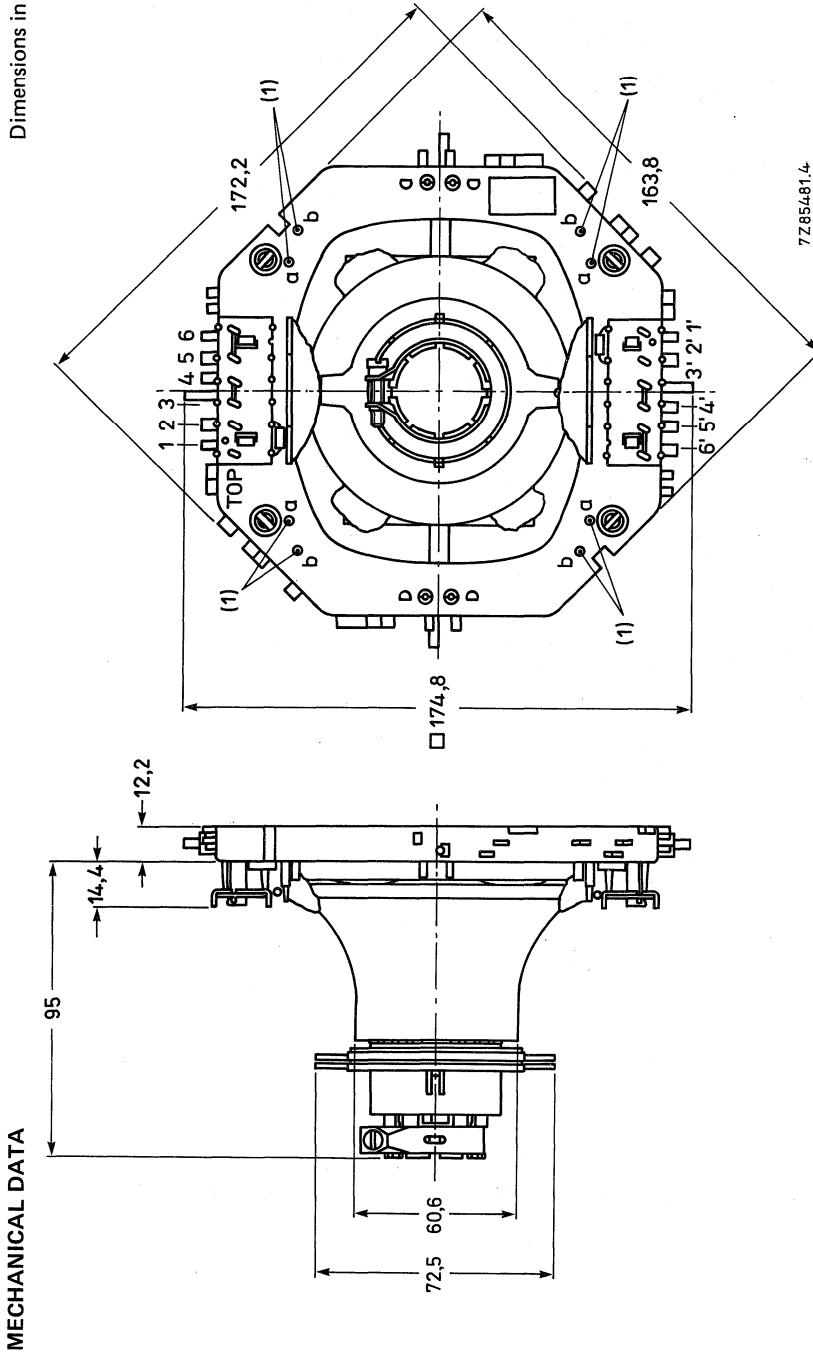

Fig. 1 Deflection unit AT 1039/05.

If a further improvement of raster geometry is required use can be made of correction magnets*, which must be fitted to mounting posts (1). The unit has solder pins for connection. The pin numbering in Fig. 1 corresponds to that in Fig. 2.

* Catalogue number 3122 134 92300.

ELECTRICAL DATA

	parallel connected	series connected
Line deflection coils		
inductance	107,5 $\mu\text{H} \pm 5\%$	430 $\mu\text{H} \pm 5\%$
resistance	0,18 $\Omega \pm 10\%$	0,72 $\Omega \pm 5\%$
line deflection current for raster scan, at 17 kV raster scan	10,5 A (p-p) $\pm 5\%$ 259 mm	5,25 A (p-p) $\pm 5\%$ 259 mm
Field deflection coils		
inductance	2,38 mH $\pm 5\%$	9,5 mH $\pm 5\%$
resistance	2,6 $\Omega \pm 5\%$	10,4 $\Omega \pm 5\%$
field deflection current for raster scan, at 17 kV raster scan	1,9 A (p-p) $\pm 5\%$ 194 mm	0,95 A (p-p) $\pm 5\%$ 194 mm

Maximum permissible DC voltage between line and field coils 3000 V
 Maximum permissible DC voltage between field coil and yoke ring 300 V
 Coupling between line and field coils, at 1 V, 500 Hz $\leq 1/100$

Note: The values apply at an ambient temperature of 23 °C

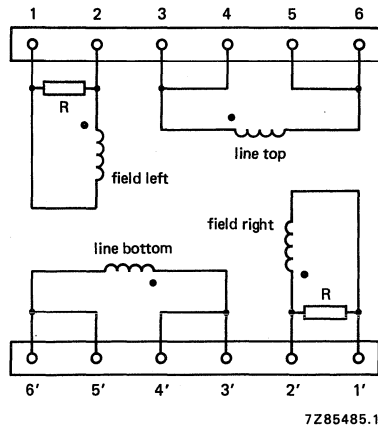

Fig. 2 Diagram of line and field coils; R = 270 Ω . The beginning of the windings is indicated with ●.

Interconnections

	terminals to be interconnected	output terminals*	
		live	neutral
Line deflection coils			
parallel connection	3, 4 to 5', 6' and 3', 4' to 5, 6	<u>3, 4</u> 5', 6'	3', <u>4'</u> , 5, 6
series connection	3, 4 to 3', 4'	5', <u>6'</u>	<u>5</u> , 6
Field deflection coils			
parallel connection	1 to 2' and 1' to 2	<u>1'</u> , 2	1, <u>2'</u>
series connection	2 to 2'	<u>1'</u>	<u>1</u>

* Terminals which are most convenient to be used as output terminals are underlined.

Geometric distortion, without raster correction and centring magnets.

DEVELOPMENT DATA

Fig. 3 Raster scan.

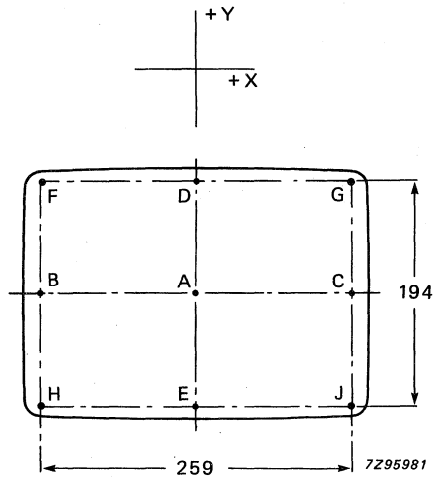

Obliquity

- |Fy-Gy| ≤ 2.0 mm
- |Gx-Jx| ≤ 2.0 mm
- |Jy-Hy| ≤ 2.0 mm
- |Hx-Fx| ≤ 2.0 mm
- |Dx-Ex| ≤ 0.5 mm
- |By-Cy| ≤ 0.5 mm

Fig. 4 Obliquity.

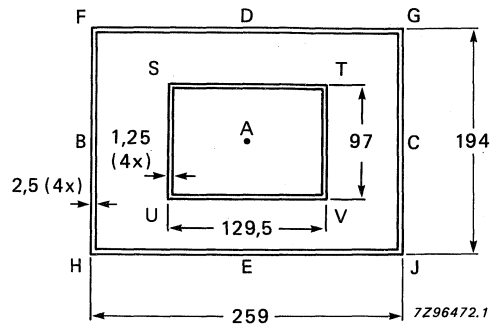

Note: The edges of the displayed raster should fall within the two rectangles.

Spot quality and measurement (refer to Fig. 3)

To be measured according to TVV55-84-0002.

Mean spot dimension is related to the spot at point A.

$$\text{Mean spot size} = \frac{1 + s}{2} \quad \text{Where; } 1 = \text{longest spot axis}$$

$$s = \text{shortest spot axis}$$

Measuring conditions:

$$V_{ht} = 17 \text{ kV}$$

$$V_{g2} = 700 \text{ V}$$

$$I_a = 100 \mu\text{A}$$

The following values for spot growth are defined with DC-deflection and optimal focus voltage V_{g4} per measuring point:

$$\text{spot size B and C} = \text{spot size A} + 15\% \pm 20\%$$

$$\text{spot size D and E} = \text{spot size A} + 15\% \pm 20\%$$

$$\text{spot size F,G,H and J} = \text{spot size A} + 25\% \pm 20\%$$

ENVIRONMENTAL DATA

Maximum operating temperature (average copper temperature)	95 °C
Maximum possible temperature rise (ΔT) as a result of coil losses at 50 kHz	35 °C
Storage temperature range	-25 to + 95 °C
Flame retarding	according to UL1413
Flammability	according to UL94, category V1

ENVIRONMENTAL TESTS

The deflection units withstand the following tests:

Vibration	IEC 68-2-6; test Fc, procedure B4; 10-55-10 Hz, amplitude 0.35 mm, 3 x 30 min.
Bump	IEC 68-2-29, test Eb; 250 m/s ² , 1000 bumps, 6 directions.
Shock	IEC 68-2-27, test Ea; 11 ms, half-sine pulse shape, 350 m/s ² , 3 x 6 directions.
Cold	IEC 68-2-1, test Ab; 96 h, -25 °C.
Dry heat	IEC 68-2-2, test Bb; 96 h, + 95 °C.
Cyclic damp heat	IEC 68-2-30, test Db; 21 cycles, + 40 °C.
Damp heat, steady state	IEC 68-2-3, test Ca, 21 days.
Change of temperature	IEC 68-2-14, test Nb; 5 cycles of 2 h at -25 °C and 2 h at + 95 °C, duration of one cycle 5 h.

BEAM CENTRING

The deflection units have two independently movable centring magnets of plastic-bonded Ferroxdure. These magnets are for placing the electron beam coaxially with the deflection coils. They are magnetized diametrically. By turning the magnets with respect to each other the resulting field strength is varied. The direction of the resulting magnetic field is adjusted by turning the magnets simultaneously. The required torque on the magnets is 35 to 250 mNm. See also Fig. 5.

The correct position of the magnets ensures freedom from curved lines in the centre of the raster and is beneficial with regard to raster geometry, deflection defocusing, corner cutting etc. For quality performance, picture shift should be obtained by applying d.c. current through the deflection coils.

This should be done after adjustment of raster linearity and after correct phasing of displayed information in respect of the raster.

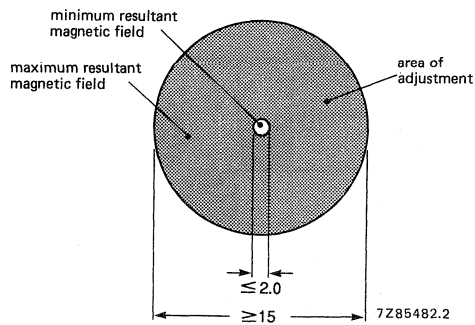

Fig. 5.

PACKING

The deflection units are packed on pallets of 10 or 15 boxes. Each box contains 24 deflection units.

DEVELOPMENT DATA

This data sheet contains advance information and specifications are subject to change without notice.

AT1039/08
AT1039/09

DEFLECTION UNITS

- For Data Graphic Displays
- For use with high resolution 47 cm (20 in) and 41 cm (17 in)/110° monochrome CRTs
- Optimized for minimum deflection defocusing
- Preset raster geometry for high resolution monitor tubes M47EAA and M41EAA
- Electrical data given is for M47EAA
- Separate types for landscape and portrait formats

QUICK REFERENCE DATA

	AT1039/08	AT1039/09
Deflection angle	110°	110°
Neck diameter of CRT	28.6 mm	28.6 mm
Screen diagonal of CRT	47/41 cm	47/41 cm
Display format	portrait	landscape
Line deflection current for raster scan, at 20 kV	6.27 A (p-p)	8.16 A (p-p)
Inductance of line coils, parallel connected	230 μ H	213 μ H
Field deflection current for raster scan, at 20 kV	1.39 A (p-p)	1.08 A (p-p)
Resistance of field coils, series connected	10.4 Ω	10.5 Ω

APPLICATION

These deflection units are for Data Graphic Displays, especially when high resolution and/or high frequency operation is required. They are developed in conjunction with the high resolution monitor tube M47EAA to provide minimum deflection defocusing and good raster geometry without additional adjustments. The AT1039/08 and AT1039/09 display the same very high performance when used in conjunction with the M41EAA high resolution monitor tube.

Deflection unit AT1039/08 is for displays in vertical (portrait) format, AT1039/09 for displays in horizontal (landscape, TV) format.

To utilize the full potential of these deflection units in respect of deflection defocusing, dynamic focusing has to be applied in horizontal and vertical directions.

The line scan frequency is limited by the temperature of the deflection coils. The practical value depends on environmental conditions, but in general terms the highest operating frequency is approx. 50 kHz in landscape format and approx. 70 kHz in portrait format. At this line frequency the temperature rise of the deflection unit is less than 35 °C, the maximum allowed average copper temperature of the unit is 95 °C, hence, the environmental temperature must not exceed 60 °C. Where the circuitry and cabinet design are such that an operating environmental temperature of less than 60 °C is attained, the maximum permissible line frequency may be higher than the 50 kHz/70 kHz specified.

To provide some choice of impedances, the termination of the coils are brought out permitting either series or parallel connections.

When the coils are connected in parallel it is possible to provide scan at the highest frequency using existing devices. The impedance of the field coils (series connected) is adjusted for operation with integrated circuits (e.g. TDA2653A).

The following associated wound components are available for use in line time base circuits:

- AT2076/84 – universal line output transformer;
- AT4042/33A – linearity control unit (parallel connection);
- AT4042/08A – linearity control unit (series connection);
- AT4043/64 – line driver transformer;
- AT4043/29 – d.c. shift transformer;
- AT4044/35 – amplitude control unit.

A universal monitor design (C64) has been developed, which is based on AT1039 deflection coils; it permits adjustment of the operating frequencies to the desired value by replacement of a few components only.

Further details are available on request.

DESCRIPTION

The line and field deflection coils are basically saddle-shaped and are surrounded by a Ferroxcube yoke ring. A special winding technique guarantees a precise magnetic field and a high reproducibility. Ferroxdure magnets are provided for beam centring. Provisions are made for mounting raster correction magnets.

The units meet the self-extinguishing requirements of CSA, IEC and UL.

The top of the units is marked.

MOUNTING

The unit should be mounted as far forward as possible on the neck of the tube so that it touches the cone; the maximum push-on force on the tube is 50 N.

To orient the raster correctly, the unit may be rotated by hand on the neck of the tube, with which it makes a slip fit. A screw-tightened clamping ring permits it to be locked, both axially and radially, in the desired position; the tightening torque is 0.75 to 0.90 Nm.

DEVELOPMENT DATA

Dimensions in mm

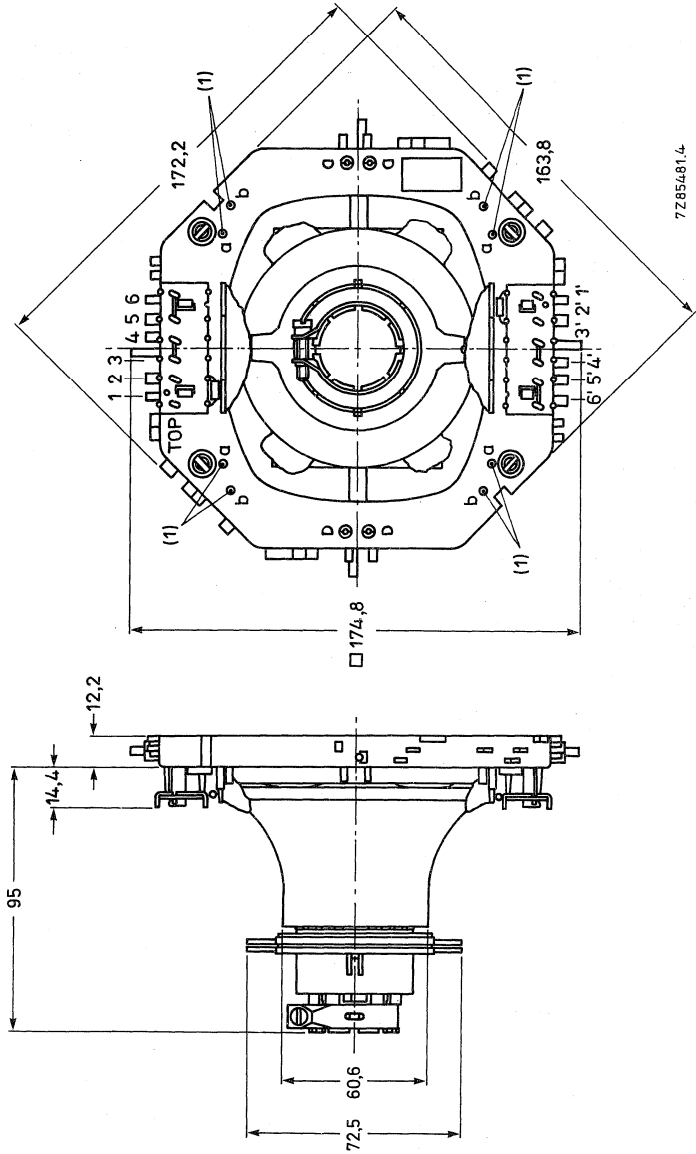

Fig. 1 Deflection units AT1039/08 and AT1039/09.

If a further improvement of raster geometry is required use can be made of correction magnets*, which must be fitted to mounting posts (1); posts a to be used for AT1039/08, posts b for AT1039/09. The unit has solder pins for connection. The pin numbering in Fig. 1 corresponds to that in Fig. 2.

* Catalogue number 3122 134 92300.

MECHANICAL DATA

	AT1039/08		AT1039/09	
	parallel connected	series connected	parallel connected	series connected
Line deflection coils				
inductance	230 $\mu\text{H} \pm 5\%$	920 $\mu\text{H} \pm 5\%$	213 $\mu\text{H} \pm 5\%$	852 $\mu\text{H} \pm 5\%$
resistance	0.39 $\Omega \pm 5\%$	1.56 $\Omega \pm 5\%$	0.37 $\Omega \pm 5\%$	1.48 $\Omega \pm 5\%$
line deflection current, for raster scan, at 20 kV	6.27 A (p-p) $\pm 5\%$	3.14 A (p-p) $\pm 5\%$	8.16 A (p-p) $\pm 5\%$	4.03 A (p-p) $\pm 5\%$
raster scan	261 mm	261 mm	348 mm	348 mm
Field deflection coils				
inductance	2.33 mH $\pm 5\%$	9.30 mH $\pm 5\%$	2.38 mH $\pm 5\%$	9.50 mH $\pm 5\%$
resistance	2.60 $\Omega \pm 5\%$	10.4 $\Omega \pm 5\%$	2.63 $\Omega \pm 5\%$	10.5 $\Omega \pm 5\%$
field deflection current, for raster scan, at 20 kV	2.78 A (p-p) $\pm 5\%$	1.39 A (p-p) $\pm 5\%$	2.16 A (p-p) $\pm 5\%$	1.08 A (p-p) $\pm 5\%$
raster scan	348 mm	348 mm	261 mm	261 mm

Maximum permissible DC voltage between line and field coils 3000 V
 Maximum permissible DC voltage between field coil and yoke ring 300 V
 Coupling between line and field coils, at 1 V, 500 Hz $\leq 1/100$

Note: The values apply at an ambient temperature of 23 °C.

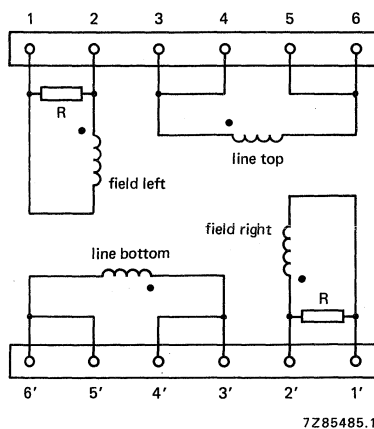

Fig. 2 Diagram of line and field coils; R = 270 Ω . The beginning of the windings is indicated with ●.

Interconnections

	terminals to be interconnected	output terminals*	
		live	neutral
<u>Line deflection coils</u>			
parallel connection	3, 4 to 5', 6' and 3', 4' to 5, 6	<u>3, 4</u> <u>5', 6'</u>	<u>3', 4'</u> , 5, 6
series connection	3, 4 to 3', 4'	<u>5', 6'</u>	<u>5, 6</u>
<u>Field deflection coils</u>			
parallel connection	1 to 2' and 1' to 2	<u>1', 2</u>	<u>1, 2'</u>
series connection	2 to 2'	<u>1'</u>	<u>1</u>

* Terminals which are most convenient to be used as output terminals are underlined.

Geometric distortion, without raster correction and centring magnets.

DEVELOPMENT DATA

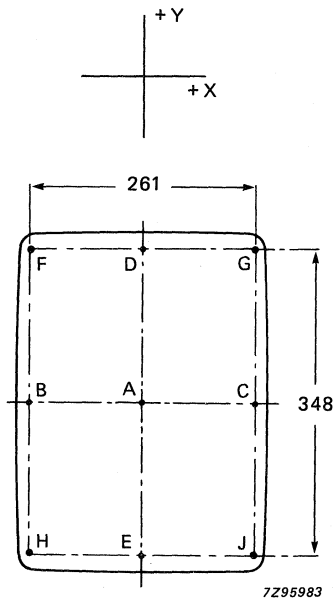

Fig. 3a AT1039/08.

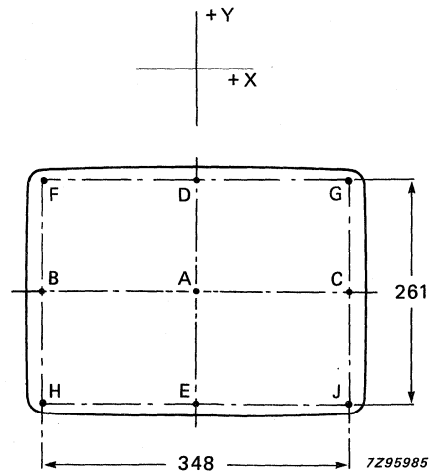

Fig. 3b AT1039/09.

ENVIRONMENTAL DATA

Maximum operating temperature (average copper temperature)	95 °C
Maximum possible temperature rise (ΔT) as a result of coil losses at 50 kHz and 70 kHz respectively	35 °C
Storage temperature range	-25 to + 95 °C
Flame retarding	according to UL1413
Flammability	according to UL94, category V1

ENVIRONMENTAL TESTS

The deflection units withstand the following tests:

DEVELOPMENT DATA	Vibration	IEC 68-2-6; test Fc, procedure B4; 10-55-10 Hz, amplitude 0,35 mm, 3 x 30 min.
	Bump	IEC 68-2-29, test Eb; 250 m/s ² , 1000 bumps, 6 directions.
	Shock	IEC 68-2-27, test Ea; 11 ms, half-sine pulse shape, 350 m/s ² , 3 x 6 directions.
	Cold	IEC 68-2-1, test Ab; 96 h, -25 °C.
	Dry heat	IEC 68-2-2, test Bb; 96 h, + 95 °C.
	Cyclic damp heat	IEC 68-2-30, test Db; 21 cycles, + 40 °C.
	Damp heat, steady state	IEC 68-2-3, test Ca, 21 days.
	Change of temperature	IEC 68-2-14, test Nb; 5 cycles of 2 h at -25 °C and 2 h at + 95 °C, duration of one cycle 5 h.

BEAM CENTRING

The deflection units have two independently movable centring magnets of plastic-bonded Ferroxdure. These magnets are for placing the electron beam coaxially with the deflection coils. They are magnetized diametrically. By turning the magnets with respect to each other the resulting field strength is varied. The direction of the resulting magnetic field is adjusted by turning the magnets simultaneously. The required torque on the magnets is 35 to 250 mNm. See also Fig. 5.

The correct position of the magnets ensures freedom from curved lines in the centre of the raster and is beneficial with regard to raster geometry, deflection defocusing, corner cutting etc. For quality performance, picture shift should be obtained by applying d.c. current through the deflection coils. This should be done after adjustment of raster linearity and after correct phasing of displayed information in respect of the raster.

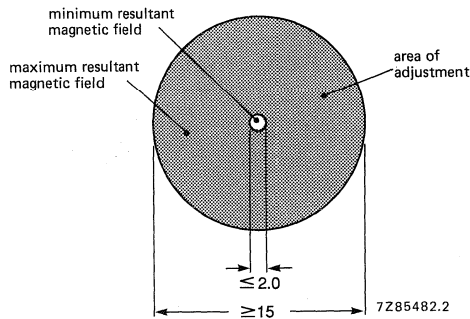

Fig. 5.

PACKING

The deflection units are packed on pallets of 10 or 15 boxes. Each box contains 24 deflection units.

DEVELOPMENT DATA

This data sheet contains advance information and specifications are subject to change without notice.

AT1039/20
AT1039/21

DEFLECTION UNITS

- For Data Graphic Displays
- For use with high resolution 36 cm (15 in)/110 FLAT SQUARE monochrome CRT's
- Optimized for minimum deflection defocusing
- Preset raster geometry for high resolution monitor tube M36EAB
- Separate types for landscape and portrait formats

QUICK REFERENCE DATA

	AT1039/20	AT1039/21
Deflection angle	110°	110°
Neck diameter of CRT	28.6 mm	28.6 mm
Screen diagonal of CRT	36 cm	36 cm
Display format	portrait	landscape
Line deflection current for raster scan, at 17 kV	5.66 A (p-p)	7.64 A (p-p)
Inductance of line coils, parallel connected	233 μ H	205 μ H
Field deflection current for raster scan, at 17 kV	1.32 A (p-p)	0.95 A (p-p)
Resistance of field coils, series connected	10.0 Ω	10.4 Ω

APPLICATION

These deflection units are for Data Graphic Displays, especially when high resolution and/or high frequency operation is required. They are developed in conjunction with the high resolution monitor tube M36EAB to provide minimum deflection defocusing and good raster geometry without additional adjustments.

Deflection unit AT1039/20 is for displays in vertical (portrait) format, AT1039/21 for displays in horizontal (landscape, TV) format.

To utilize the full potential of these deflection units in respect of deflection defocusing, dynamic focusing has to be applied in horizontal and vertical directions.

The line scan frequency is limited by the temperature of the deflection coils. The practical value depends on environmental conditions, but in general terms the highest operating frequency is approx. 50 kHz in landscape format and approx. 70 kHz in portrait format. At this line frequency the temperature rise of the deflection unit is less than 35 °C, the maximum allowed average copper temperature of the unit is 95 °C, hence, the environmental temperature must not exceed 60 °C. Where the circuitry and cabinet design are such that an operating environmental temperature of less than 60 °C is attained, the maximum permissible line frequency may be higher than the 50 kHz/70 kHz specified.

To provide some choice of impedances, the termination of the coils are brought out permitting either series or parallel connections.

When the coils are connected in parallel it is possible to provide scan at the highest frequency using existing devices. The impedance of the field coils (series connected) is adjusted for operation with integrated circuits (e.g. TDA2653A).

The following associated wound components are available for use in line time base circuits:

- AT2076/84 — universal line output transformer;
- AT4042/33A — linearity control unit (parallel connection);
- AT4042/08A — linearity control unit (series connection);
- AT4043/64 — line driver transformer;
- AT4043/29 — d.c. shift transformer;
- AT4044/35 — amplitude control unit.

A universal monitor design (C64) has been developed, which is based on AT1039 deflection coils; it permits adjustment of the operating frequencies to the desired value by replacement of a few components only.

Further details are available on request.

DESCRIPTION

The line and field deflection coils are basically saddle-shaped and are surrounded by a Ferroxcube yoke ring. A special winding technique guarantees a precise magnetic field and a high reproducibility. Ferroxdure magnets are provided for beam centring. Provisions are made for mounting raster correction magnets.

The units meet the self-extinguishing requirements of CSA, IEC and UL.

The top of the units is marked.

MOUNTING

The unit should be mounted as far forward as possible on the neck of the tube so that it touches the cone; the maximum push-on force on the tube is 50 N.

To orient the raster correctly, the unit may be rotated by hand on the neck of the tube, with which it makes a slip fit. A screw-tightened clamping ring permits it to be locked, both axially and radially, in the desired position; the tightening torque is 0.75 to 0.90 Nm.

DEVELOPMENT DATA

Dimensions in mm

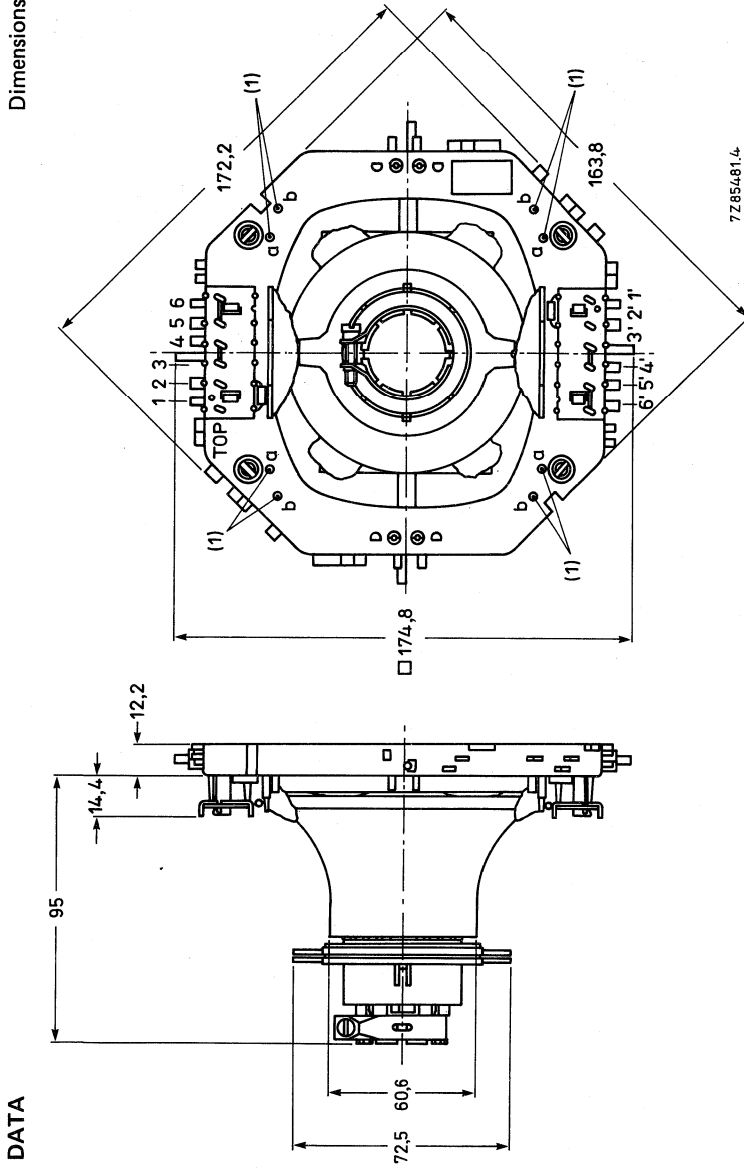

Fig. 1 Deflection units AT 1039/20 and AT 1039/21.

If a further improvement of raster geometry is required use can be made of correction magnets*, which must be fitted to mounting posts (1); posts a to be used for AT 1039/20, posts b for AT 1039/21. The unit has solder pins for connection. The pin numbering in Fig. 1 corresponds to that in Fig. 2.

* Catalogue number 3122 134 92300.

ELECTRICAL DATA

	AT1039/20		AT1039/21	
	parallel connected	series connected	parallel connected	series connected
Line deflection coils				
inductance	233 $\mu\text{H} \pm 5\%$	932 $\mu\text{H} \pm 5\%$	205 $\mu\text{H} \pm 5\%$	820 $\mu\text{H} \pm 5\%$
resistance	0.38 $\Omega \pm 5\%$	1.52 $\Omega \pm 5\%$	0.35 $\Omega \pm 5\%$	1.40 $\Omega \pm 5\%$
line deflection current for raster scan at 17 kV raster scan	5.66 A(p-p) $\pm 5\%$ 200 mm	2.83 A(p-p) $\pm 5\%$ 200 mm	7.64 A(p-p) $\pm 5\%$ 267 mm	3.82 A(p-p) $\pm 5\%$ 267 mm
Field deflection coils				
inductance	2.20 mH $\pm 5\%$	8.80 mH $\pm 5\%$	2.38 mH $\pm 5\%$	9.50 mH $\pm 5\%$
resistance	2.50 $\Omega \pm 5\%$	10.0 $\Omega \pm 5\%$	2.60 $\Omega \pm 5\%$	10.4 $\Omega \pm 5\%$
field deflection current for raster scan at 17 kV raster scan	2.64 A(p-p) $\pm 5\%$ 267 mm	1.32 A(p-p) $\pm 5\%$ 267 mm	1.90 A(p-p) $\pm 5\%$ 200 mm	0.95 A(p-p) $\pm 5\%$ 200 mm

Maximum permissible DC voltage between line and field coils 3000 V
 Maximum permissible DC voltage between field coil and yoke ring 300 V
 Coupling between line and field coils, at 1 V, 500 Hz $\leq 1/100$

Note: The values apply at an ambient temperature of 23 °C.

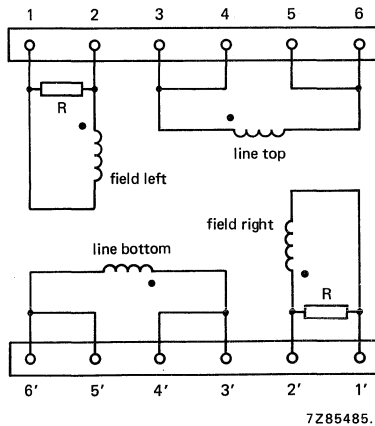

Fig. 2 Diagram of line and field coils; R = 270 Ω . The beginning of the windings is indicated with ●.

Interconnections

	terminals to be interconnected	output terminals*	
		live	neutral
<u>Line deflection coils</u>			
parallel connection	3, 4 to 5', 6' and 3', 4' to 5, 6	<u>3, 4</u> <u>5', 6'</u>	<u>3', 4'</u> , 5, 6
series connection	3, 4 to 3', 4'	<u>5', 6'</u>	<u>5, 6</u>
<u>Field deflection coils</u>			
parallel connection	1 to 2' and 1' to 2	<u>1', 2</u>	<u>1, 2'</u>
series connection	2 to 2'	<u>1'</u>	<u>1</u>

* Terminals which are most convenient to be used as output terminals are underlined.

Geometric distortion, without raster correction and centring magnets.

DEVELOPMENT DATA

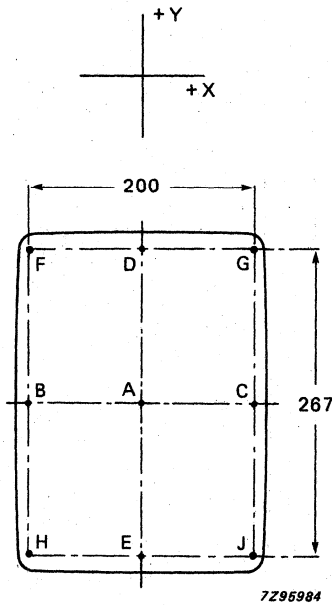

Fig. 3a AT1039/20.

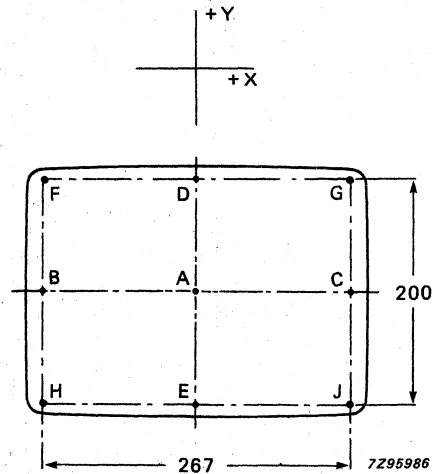

Fig. 3b AT1039/21.

Obliquity

$$\begin{aligned}
 |Fy-Gy| &\leq 2.5 \text{ mm} \\
 |Gx-Jx| &\leq 2.5 \text{ mm} \\
 |Jy-Hy| &\leq 2.5 \text{ mm} \\
 |Hx-Fx| &\leq 2.5 \text{ mm} \\
 |Dx| \text{ and } |Ex| &\leq 0.8 \text{ mm} \\
 |By| \text{ and } |Cy| &\leq 0.5 \text{ mm}
 \end{aligned}$$

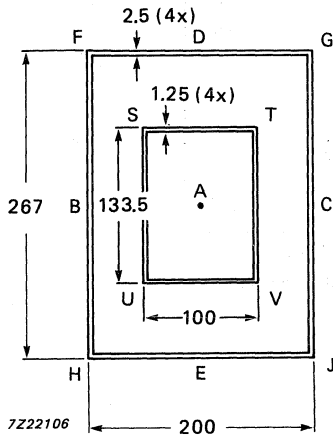

Fig. 4a AT1039/20.

Spot quality and measurement (refer to Fig. 3)

To be measured according to TVV55-84-0002.

Mean spot dimension is related to the spot at point A.

$$\text{Mean spot size} = \frac{1 + s}{2}$$

Where; 1 = longest spot axis
s = shortest spot axis

Measuring conditions:

$$\begin{aligned}
 V_{ht} &= 17 \text{ kV} \\
 V_{g2} &= 700 \text{ V} \\
 I_a &= 100 \mu\text{A}
 \end{aligned}$$

The following values for spot growth are defined with DC-deflection and optimal focus voltage V_{g4} per measuring point:

- spot size B and C = spot size A + 15% ± 20%
- spot size D and E = spot size A + 15% ± 20%
- spot size F, G, H and J = spot size A + 25% ± 20%

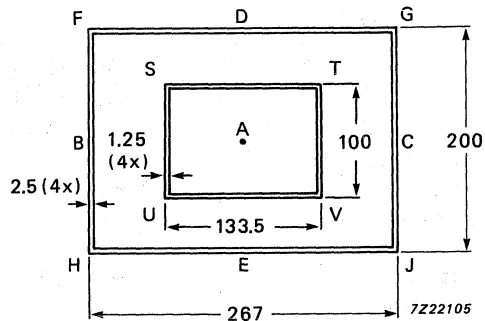

Fig. 4b AT1039/21.

Note: The edges of the displayed raster should fall within the two rectangles.

ENVIRONMENTAL DATA

Maximum operating temperature (average copper temperature)	95 °C
Maximum possible temperature rise (ΔT) as a result of coil losses at 50 kHz and 70 kHz respectively	35 °C
Storage temperature range	-25 to + 95 °C
Flame retarding	according to UL1413
Flammability	according to UL94, category V1

ENVIRONMENTAL TESTS

The deflection units withstand the following tests:

Vibration	IEC 68-2-6; test Fc, procedure B4; 10-55-10 Hz, amplitude 0,35 mm, 3 x 30 min.
Bump	IEC 68-2-29, test Eb; 250 m/s ² , 1000 bumps, 6 directions.
Shock	IEC 68-2-27, test Ea; 11 ms, half-sine pulse shape, 350 m/s ² , 3 x 6 directions.
Cold	IEC 68-2-1, test Ab; 96 h, -25 °C.
Dry heat	IEC 68-2-2, test Bb; 96 h, + 95 °C.
Cyclic damp heat	IEC 68-2-30, test Db; 21 cycles, + 40 °C.
Damp heat, steady state	IEC 68-2-3, test Ca, 21 days.
Change of temperature	IEC 68-2-14, test Nb; 5 cycles of 2 h at -25 °C and 2 h at + 95 °C, duration of one cycle 5 h.

DEVELOPMENT DATA

BEAM CENTRING

The deflection units have two independently movable centring magnets of plastic-bonded Ferroxdure. These magnets are for placing the electron beam coaxially with the deflection coils. They are magnetized diametrically. By turning the magnets with respect to each other the resulting field strength is varied. The direction of the resulting magnetic field is adjusted by turning the magnets simultaneously. The required torque on the magnets is 35 to 250 mNm. See also Fig. 5.

The correct position of the magnets ensures freedom from curved lines in the centre of the raster and is beneficial with regard to raster geometry, deflection defocusing, corner cutting etc. For quality performance, picture shift should be obtained by applying d.c. current through the deflection coils.

This should be done after adjustment of raster linearity and after correct phasing of displayed information in respect of the raster.

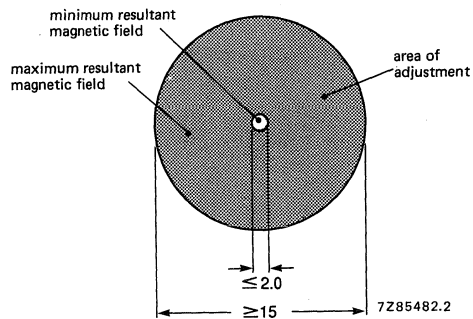

Fig. 5.

PACKING

The deflection units are packed on pallets of 10 or 15 boxes. Each box contains 24 deflection units.

DEVELOPMENT DATA

This data sheet contains advance information and specifications are subject to change without notice.

AT1039/39

DEFLECTION UNIT

- For Data Graphic Displays
- For use with high resolution 47 cm (20 in) and 41 cm (17 in)/110° monochrome CRTs
- Optimized for minimum deflection defocusing
- Preset raster geometry for high resolution monitor tubes M47EAA and M41EAA
- Electrical data given is for M47EAA

QUICK REFERENCE DATA

Deflection angle	110°
Neck diameter of CRT	28.6 mm
Screen diagonal of CRT	47/41 cm
Display format	landscape
Line deflection current for raster scan, at 17.5 kV	11.0 A (p-p)
Inductance of line coils, parallel connected	111 μ A
Field deflection current for raster scan, at 17.5 kV	1.04 A (p-p)
Resistance of field coils, series connected	10.4 Ω

APPLICATION

This deflection unit is for Data Graphic Displays, especially when high resolution and/or high frequency operation is required. It is developed in conjunction with the high resolution monitor tube M47EAA to provide minimum deflection defocusing and good raster geometry without additional adjustments. Deflection unit AT1039/39 is for displays in horizontal (landscape, TV) format.

The AT1039/39 displays the same very high performance when used in conjunction with the M41EAA high resolution monitor tube.

To utilize the full potential of these deflection units in respect of deflection defocusing, dynamic focusing has to be applied in horizontal and vertical directions.

The line scan frequency is limited by the temperature of the deflection coils. The practical value depends on environmental conditions, but in general terms the highest operating frequency is approx. 50 kHz. At this line frequency the temperature rise of the deflection unit is less than 35°C, the maximum allowed average copper temperature of the unit is 95°C, hence, the environmental temperature must not exceed 60°C. Where the circuitry and cabinet design are such that an operating environmental temperature of less than 60°C is attained, the maximum permissible line frequency may be higher than the 50 kHz specified.

To provide some choice of impedances, the terminations of the coils are brought out permitting either series or parallel connections.

When the coils are connected in parallel it is possible to provide scan at the highest frequency using existing devices. The impedance of the field coils (series connected) is adjusted for operation with integrated circuits (e.g. TDA2653A).

The following associated wound components are available for use in line time base circuits:

- AT2076/84 — universal line output transformer;
- AT4042/33A — linearity control unit (parallel connection);
- AT4042/08A — linearity control unit (series connection);
- AT4043/64 — line driver transformer;
- AT4043/29 — DC. shift transformer;
- AT4044/35 — amplitude control unit.

A universal monitor design (C64) has been developed, which is based on AT1039 deflection coils; it permits adjustment of the operating frequencies to the desired value by replacement of a few components only.

Further details are available on request.

DESCRIPTION

The line and field deflection coils are basically saddle-shaped and are surrounded by a Ferroxcube yoke ring. A special winding technique guarantees a precise magnetic field and a high reproducibility. Ferroxdure magnets are provided for beam centring. Provisions are made for mounting raster correction magnets.

The unit meets the self-extinguishing requirements of CSA, IEC and UL.

The top of the unit is marked.

MOUNTING

The unit should be mounted as far forward as possible on the neck of the tube so that it touches the cone; the maximum push-on force on the tube is 50 N.

To orient the raster correctly, the unit may be rotated by hand on the neck of the tube, with which it makes a slip fit. A screw-tightened clamping ring permits it to be locked, both axially and radially, in the desired position; the tightening torque is 0.75 to 0.90 Nm.

DEVELOPMENT DATA

Dimensions in mm

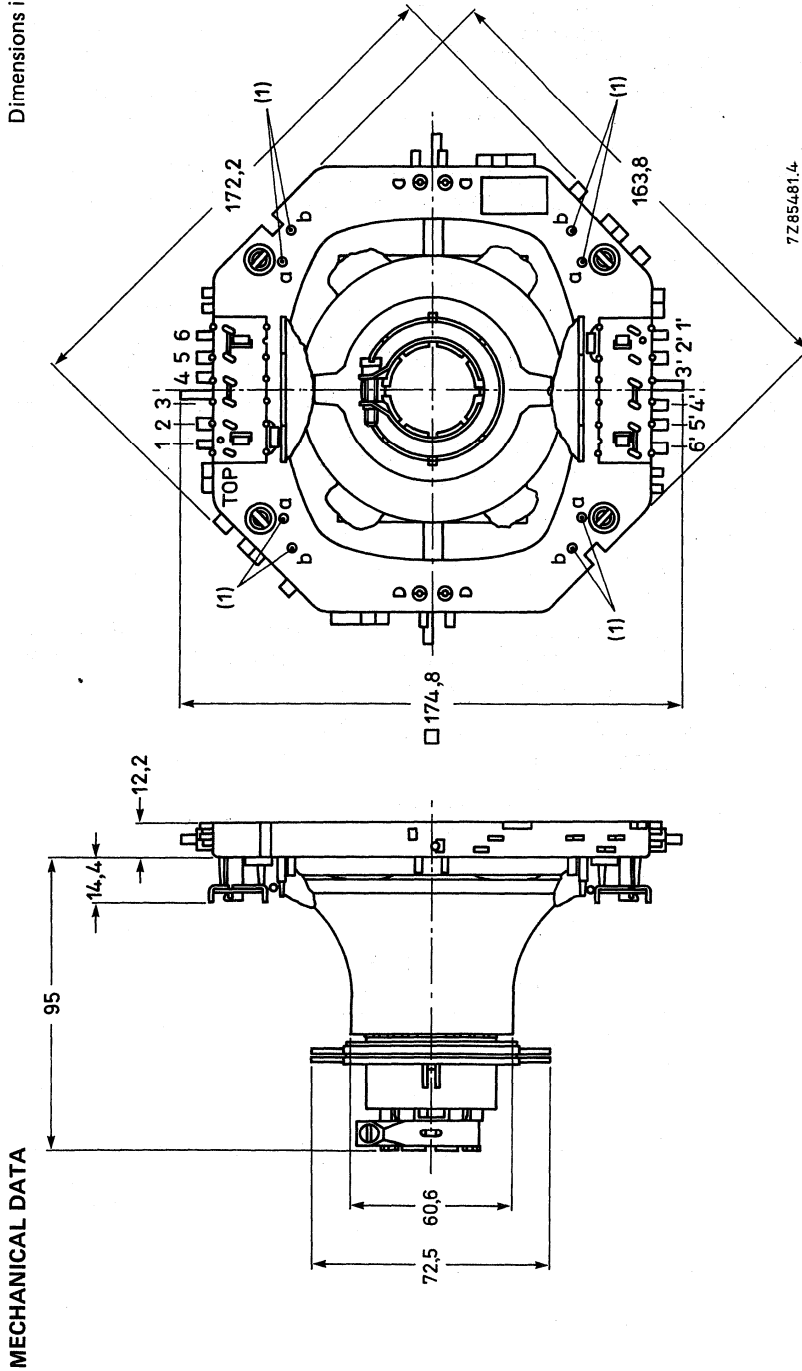

Fig. 1 Deflection unit AT1039/39.

If a further improvement of raster geometry is required use can be made of correction magnets*, which must be fitted to mounting posts (1). The unit has solder pins for connection. The pin numbering in Fig. 1 corresponds to that in Fig. 2.

* Catalogue number 3122 134 92300.

ELECTRICAL DATA

	parallel connected	series connected
Line deflection coils		
inductance	111 $\mu\text{H} \pm 5\%$	444 $\mu\text{H} \pm 5\%$
resistance	0.18 $\Omega \pm 10\%$	0.72 $\Omega \pm 5\%$
line deflection current for raster scan, at 17.5 kV raster scan	11.0 A (p-p) $\pm 5\%$ 348 mm	5.50 A (p-p) $\pm 5\%$ 348 mm
Field deflection coils		
inductance	2.38 mH $\pm 5\%$	9.5 mH $\pm 5\%$
resistance	2.60 $\Omega \pm 5\%$	10.4 $\Omega \pm 5\%$
field deflection current for raster scan, at 17.5 kV raster scan	2.08 A (p-p) $\pm 5\%$ 261 mm	1.04 A (p-p) $\pm 5\%$ 261 mm

Maximum permissible DC voltage between line and field coils

3000 V

Maximum permissible DC voltage between field coil and yoke ring

300 V

Coupling between line and field coils, at 1 V, 500 Hz

$\leq 1/100$

Note: The values apply at an ambient temperature of 23 °C

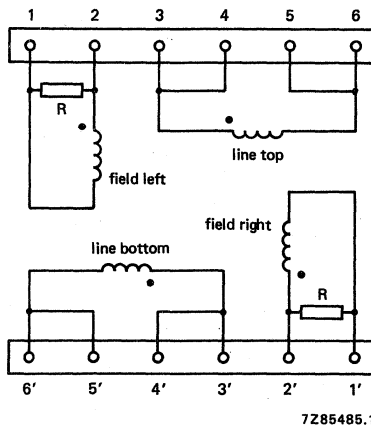

Fig. 2 Diagram of line and field coils; R = 270 Ω . The beginning of the windings is indicated with ●.

Interconnections

	terminals to be interconnected	output terminals*	
		live	neutral
Line deflection coils			
parallel connection	3, 4 to 5', 6' and 3', 4' to 5, 6	<u>3</u> , <u>4</u> , <u>5'</u> , <u>6'</u>	3', <u>4'</u> , 5, 6
series connection	3, 4 to 3', 4'	<u>5'</u> , <u>6'</u>	<u>5</u> , <u>6</u>
Field deflection coils			
parallel connection	1 to 2' and 1' to 2	<u>1'</u> , <u>2</u>	1, <u>2'</u>
series connection	2 to 2'	<u>1'</u>	<u>1</u>

* Terminals which are most convenient to be used as output terminals are underlined.

DEVELOPMENT DATA

Geometric distortion, without raster correction and centring magnets.

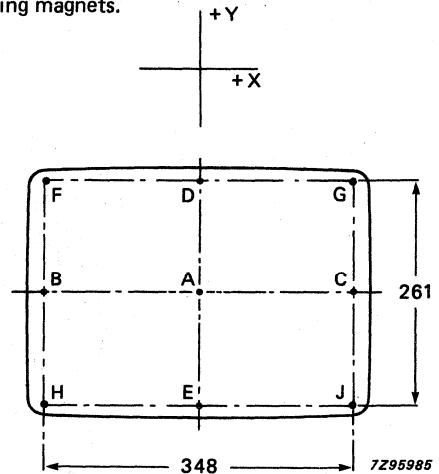

Fig. 3 Raster scan.

Obliquity

- $|F_y - G_y| \leq 3.5 \text{ mm}$
- $|G_x - J_x| \leq 3.5 \text{ mm}$
- $|J_y - H_y| \leq 3.5 \text{ mm}$
- $|H_x - F_x| \leq 3.5 \text{ mm}$
- $|D_x| \text{ and } |E_x| \leq 0.8 \text{ mm}$
- $|B_y| \text{ and } |C_y| \leq 0.5 \text{ mm}$

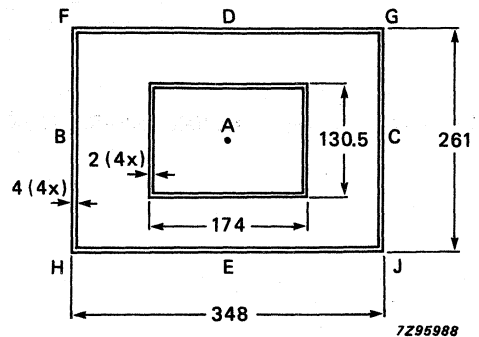

Fig. 4 Obliquity.

Note: The edges of the displayed raster should fall within the two rectangles.

BEAM CENTRING

The deflection units have two independently movable centring magnets of plastic-bonded Ferroxdure. These magnets are for placing the electron beam coaxially with the deflection coils. They are magnetized diametrically. By turning the magnets with respect to each other the resulting field strength is varied. The direction of the resulting magnetic field is adjusted by turning the magnets simultaneously. The required torque on the magnets is 35 to 250 mNm. See also Fig. 5.

The correct position of the magnets ensures freedom from curved lines in the centre of the raster and is beneficial with regard to raster geometry, deflection defocusing, corner cutting etc. For quality performance, picture shift should be obtained by applying d.c. current through the deflection coils.

This should be done after adjustment of raster linearity and after correct phasing of displayed information in respect of the raster.

DEVELOPMENT DATA

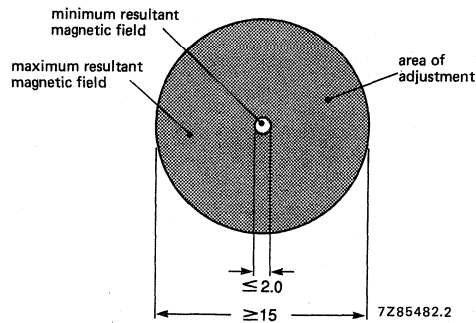

Fig. 5.

PACKING

The deflection units are packed on pallets of 10 or 15 boxes. Each box contains 24 deflection units.

ROTATION COIL

APPLICATION

This rotation coil is an optional component of the AT1037 and AT1039 yokes.

It is used to correct picture tilting at different earth magnetic fields. It can correct for up to 5 mm tilt on a 20 inch tube.

The AT1037 and AT1039 yokes including rotation coil, cable and plug have been granted UL approval.

MECHANICAL DATA

Dimensions in mm

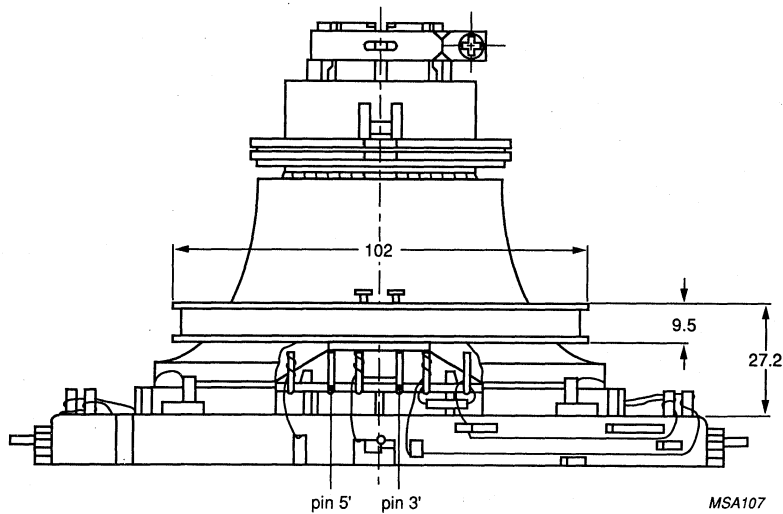

Dimensions not shown in drawing are same as for original AT1037 or AT1039 yoke used.

Fig.1 AT1037/AT1039 yoke with optional rotation coil.

ROTATION COIL

ELECTRICAL DATA

General

Inductance

14.4 mH \pm 5%

Resistance

11.5 Ω \pm 5%

Connection information

The lead outs of the rotation coil are connected to pins 3' and 5' (bottom connection board). No jump wire is fitted between pins 3' and 4' and pins 5' and 6'.

Tilt performance at line axis B, C

Applied DC current on rotation coil	raster tilt line axis
0 to 200 mA	0 to 5.0 mm

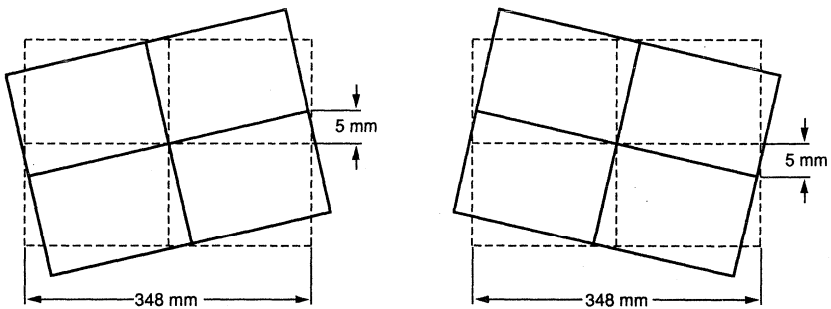

MSA108

Fig.2 Rotated line axis performance.

DATA HANDBOOK SYSTEM

DATA HANDBOOK SYSTEM

Our Data Handbook System comprises more than 60 books with specifications on electronic components, subassemblies and materials. It is made up of seven series of handbooks:

INTEGRATED CIRCUITS

DISCRETE SEMICONDUCTORS

DISPLAY COMPONENTS

PASSIVE COMPONENTS*

PROFESSIONAL COMPONENTS**

MAGNETIC PRODUCTS*

LIQUID CRYSTAL DISPLAYS

The contents of each series are listed on pages iii to ix.

The data handbooks contain all pertinent data available at the time of publication, and each is revised and reissued periodically.

Where application is given it is advisory and does not form part of the product specification.

Condensed data on the preferred products of Philips Components is given in our Preferred Type Range catalogue (issued annually).

Information on current Data Handbooks and how to obtain a subscription for future issues is available from any of the Organizations listed on the back cover.

Product specialists are at your service and enquiries will be answered promptly.

* Will replace the Components and materials (green) series of handbooks.

** Will replace the Electron tubes (blue) series of handbooks.

INTEGRATED CIRCUITS

This series of handbooks comprises:

code	handbook title
IC01	Radio, audio and associated systems Bipolar, MOS
IC02a/b	Video and associated systems Bipolar, MOS
IC03	ICs for Telecom Bipolar, MOS Subscriber sets, Cordless Telephones
IC04	HE4000B logic family CMOS
IC05	Advanced Low-power Schottky (ALS) Logic Series
IC06	High-speed CMOS; PC74HC/HCT/HCU Logic family
IC07	Advanced CMOS logic (ACL)
IC08	10/100K ECL Logic/Memory/PLD
IC09	TTL logic series
IC10	Memories MOS, TTL, ECL
IC11	Linear Products
IC12	I²C-bus compatible ICs
IC13	Semi-custom Programmable Logic Devices (PLD)
IC14	Microcontrollers NMOS, CMOS
IC15	FAST TTL logic series
IC16	CMOS integrated circuits for clocks and watches
IC17	ICs for Telecom Bipolar, MOS Radio pagers Mobile telephones ISDN
IC18	Microprocessors and peripherals
IC19	Data communication products
IC23*	Solid state image sensors and peripheral integrated circuits

* Not yet issued in this series of handbooks: previously issued as PC11.

DISCRETE SEMICONDUCTORS

This series of data handbooks comprises:

current code	new code	handbook title
S1	SC01	Diodes High-voltage tripler units
S2a	SC02	Power diodes
S2b	SC03	Thyristors and triacs
S3	SC04	Small-signal transistors
S4a	SC05	Low-frequency power transistors and hybrid IC power modules
S4b	SC06	High-voltage and switching power transistors
S5	SC07	Small-signal field-effect transistors
S6	SC08a*	RF bipolar transistors
	SC08b*	RF power transistors
	SC09	RF power modules
S7	SC10	Surface mounted semiconductors
S8b	SC12	Optocouplers
S9	SC13*	PowerMOS transistors
S10	SC14	Wideband transistors and wideband hybrid IC modules
S11	SC15	Microwave transistors
S15**	SC16	Laser diodes
S13	SC17	Semiconductor sensors

* Not yet issued with the new code in this series of handbooks.

** New handbook in this series; will be issued shortly.

DISPLAY COMPONENTS

This series of data handbooks comprises:

code handbook title

- DC01 **Colour display components**
- DC02 **Monochrome monitor tubes and deflection units**
- DC03 **Television tuners, coaxial aerial input assemblies**
- DC04 **Loudspeakers**
- DC05 **Flyback transformers, mains transformers and
general-purpose FXC assemblies**

PASSIVE COMPONENTS

This series of data handbooks comprises:

current code	new code	handbook title
C14	PA01	Electrolytic capacitors; solid and non-solid
C11	PA02	Varistors, thermistors and sensors
C12	PA03	Potentiometers and switches
C7	PA04	Variable capacitors
C22	PA05*	Film capacitors
C15	PA06*	Ceramic capacitors
C9	PA07*	Piezoelectric quartz devices
C13	PA08	Fixed resistors

* Not yet issued with the new code in this series of handbooks.

PROFESSIONAL COMPONENTS

This series of data handbooks comprises:

current code	new code	handbook title
T3	PC01	High-power klystrons and accessories
T5	PC02*	Cathode-ray tubes
T6	PC03*	Geiger-Müller tubes
T9	PC04	Photo multipliers
T10	PC05	Plumbicon camera tubes and accessories
T11	PC06	Circulators and Isolators
T12	PC07	Vidicon and Newvicon camera tubes and deflection units
T13	PC08	Image intensifiers
T15	PC09	Dry-reed switches
	PC11**	Solide state image sensors and peripheral integrated circuits
T9	PC12*	Electron multipliers

* Not yet issued with the new code in this series of handbooks.

** Will be issued as IC23 in the future.

MAGNETIC PRODUCTS

This series of data handbooks comprises:

current code	new code	handbook title
C4 } C5 }	MA01	Soft Ferrites
C16	MA02*	Permanent magnet materials
C19	MA03*	Piezoelectric ceramics

* Not yet issued with the new code in this series of handbooks.

LIQUID CRYSTAL DISPLAYS

current code	new code	handbook title
S14	LCD01	Liquid Crystal Displays and driver ICs for LCDs

Philips Components – a worldwide company

Argentina: PHILIPS ARGENTINA S.A., Div. Philips Components, Vedia 3892, 1430 BUENOS AIRES, Tel. (01)541-4261.

Australia: PHILIPS COMPONENTS PTY LTD, 11 Waltham Street, ARTARMON, N.S.W. 2064, Tel. (02)4393322.

Austria: ÖSTERREICHISCHE PHILIPS INDUSTRIE G.m.b.H., UB Bauelemente, Triester Str. 64, 1101 WIEN, Tel. (0222) 60 101-820.

Belgium: N.V. PHILIPS PROF. SYSTEMS – Components Div., 80 Rue Des Deux Gares, B-1070 BRUXELLES, Tel. (02)52 56 111.

Brazil: PHILIPS COMPONENTS (Active Devices) Av. das Nações Unidas, 12495-SAO PAULO-SP, CEP 04578, P.O. Box 7383, Tel. (011) 534-2211.

PHILIPS COMPONENTS (Passive Devices & Materials)
Av. Francisco Monteiro 702, RIBEIRAO PIRES-SP,
CEP 03400, Tel. (011) 459-8211.

Canada: PHILIPS ELECTRONICS LTD., Philips Components, 601 Milner Ave., SCARBOROUGH, Ontario, M1B 1M8, Tel. (416) 292-5161.

(IC Products) SIGNETICS CANADA LTD., 1 Eva Road, Suite 411, ETOBICOKE, Ontario, M9C 4Z5, Tel. (416) 626-6676.

Chile: PHILIPS CHILENA S.A., Av. Santa Maria 0760, SANTIAGO, Tel. (02)773816.

Colombia: IPRELENSO LTDA., Carrera 21 No. 56-17, BOGOTA, D.E., P.O. Box 77621, Tel. (01) 2497624.

Denmark: PHILIPS COMPONENTS A/S, Prags Boulevard 80, PB1919, DK-2300 COPENHAGEN S, Tel. 01-54 11 33.

Finland: PHILIPS COMPONENTS, Sinikalliontie 3, SF-2630 ESPOO, Tel. 358-0-50261.

France: PHILIPS COMPOSANTS, 117 Quai du Président Roosevelt, 92134 ISSY-LES-MOULINEAUX Cedex, Tel. (01)40938000.

Germany (Fed. Republic): PHILIPS COMPONENTS UB der Philips G.m.b.H., Valvo Haus, Burchardstrasse 19, D-2 HAMBURG 1, Tel. (040) 3296-0.

Greece: PHILIPS HELLENIQUE S.A., Components Division, No. 15, 25th March Street, GR 17778 TAVROS, Tel. (01)4894339/4894911.

Hong Kong: PHILIPS HONG KONG LTD., Components Div., 15/F Philips Ind. Bldg., 24-28 Kung Yip St., KWAI CHUNG, Tel. (0)4245 121.

India: PEICO ELECTRONICS & ELECTRICALS LTD., Components Dept., Shivsagar Estate 'A'Block, P.O. Box 6598, 254-D Dr. Annie Besant Rd., BOMBAY – 400025, Tel. (022)4921500-4921515.

Indonesia: PT. PHILIPS-RALIN ELECTRONICS, Components Div., Setiabudi II Building, 6th Fl., Jalan H.R. Rasuna Said (P.O. Box 223/KBY) Kuningan, JAKARTA 12910, Tel. (021)517995.

Ireland: PHILIPS ELECTRONICS (IRELAND) LTD., Components Division, Newstead, Clonskeagh, DUBLIN 14, Tel. (01)693355.

Italy: PHILIPS S.p.A., Philips Components, Piazza IV Novembre 3, I-20124 MILANO, Tel. (02)6752.1.

Japan: PHILIPS JAPAN LTD., Components Division, Philips Bldg 13-37, Kohnan 2-chome, Minato-ku, TOKYO 108, Tel. (03)740-5028.

Korea (Republic of): PHILIPS ELECTRONICS (KOREA) LTD., Components Division, Philips House, 260-199 taewon-dong, Yongsan-ku, SEOUL, Tel. (02)794-5011.

Malaysia: PHILIPS MALAYSIA SDN BHD, Components Div., 3 Jalan SS15/2A SUBANG, 47500 PETALING JAYA, Tel. (03)7345511.

Mexico: PHILIPS COMPONENTS, Paseo Triunfo de la Republica, No 215 Local 5, Cd Juarez CHI HUA HUA 32340 MEXICO Tel. (16) 18-67-0102.

Netherlands: PHILIPS NEDERLAND B.V., Marktgroep Philips Components, Postbus 90050, 5600 PB EINDHOVEN, Tel. (040)783749.

New Zealand: PHILIPS NEW ZEALAND LTD., Components Division, 110 Mt. Eden Road, C.P.O. Box 1041, AUCKLAND, Tel. (09)605-914.

Norway: NORSK AVS PHILIPS, Philips Components, Box 1, Manglerud 0612, OSLO, Tel. (02)680200.

Pakistan: PHILIPS ELECTRICAL CO. OF PAKISTAN LTD., Philips Markaz, M.A. Jinnah Rd., KARACHI-3, Tel. (021)725772.

Peru: CADESA, Carretera Central 6.500, LIMA 3, Apartado 5612, Tel. 51-14-350059.

Philippines: PHILIPS ELECTRICAL LAMPS INC. Components Div., 106 Valero St. Salcedo Village, Makati, METRO MANILA, P.O. Box 911, Tel. (63-2)810-0161.

Portugal: PHILIPS PORTUGUESA S.A.R.L., Av. Eng. Duarte Pacheco 6, 1009 LISBOA Codex, Tel. (019)683121.

Singapore: PHILIPS SINGAPORE, PTE LTD., Components Div., Lorong 1, Toa Payoh, SINGAPORE 1231, Tel. 3502000.

South Africa: S.A. PHILIPS PTY LTD., Components Division, JOHANNESBURG 2000, P.O. Box 7430.

Spain: PHILIPS COMPONENTS, Balmes 22, 08007 BARCELONA, Tel. (03)301 63 12.

Sweden: PHILIPS COMPONENTS, A.B., Tegeluddsvägen 1, S-11584 STOCKHOLM, Tel. (08-7821000).

Switzerland: PHILIPS A.G., Components Dept., Allmendstrasse 140-142, CH-8027 ZÜRICH, Tel. (01)48822 11.

Taiwan: PHILIPS TAIWAN LTD., 581 Min Sheng East Road, P.O. Box 22978, TAIPEI 10446, Taiwan, Tel. 886-2-5005899.

Thailand: PHILIPS ELECTRICAL CO. OF THAILAND LTD., 283 Silom Road, P.O. Box 961, BANGKOK, Tel. (02)233-6330-9.

Turkey: TÜRK PHILIPS TICARET A.Ş., Philips Components, Talatpasa Cad. No. 5, 80640 LEVENT/İSTANBUL, Tel. (01)1792770.

United Kingdom: PHILIPS COMPONENTS LTD., Mullard House, Torrington Place, LONDON WC1E 7HD, Tel. (071)5806633.

United States: (Colour picture tubes – Monochrome & Colour Display Tubes) PHILIPS DISPLAY COMPONENTS COMPANY, 1600 Huron Parkway, P.O. Box 963, ANN ARBOR, Michigan 48106, Tel. 313/996-9400.
(IC Products) SIGNETICS CORPORATION, 811 East Arques Avenue, SUNNYVALE, CA 94088-3409, Tel. (408)991-2000.
(Passive Components, Discrete Semiconductors, Materials and Professional Components) PHILIPS COMPONENTS, Discrete Products Division, 2001 West Blue Heron Blvd., P.O. Box 10330, RIVIERA BEACH, Florida 33404, Tel. (407)881-3200.

Uruguay: PHILIPS COMPONENTS, Coronel Mora 433, MONTEVIDEO, Tel. (02)70-4044.

Venezuela: MAGNETICA S.A., Calle 6, Ed. Las Tres Jotas, CARACAS 1074A, App. Post. 78117, Tel. (02)241 75 09.

Zimbabwe: PHILIPS ELECTRICAL (PVT) LTD., 62 Mutare Road, HARARE, P.O. Box 994, Tel. 47211.

For all other countries apply to: Philips Components Division, Strategic Accounts and International Sales, P.O. Box 218, 5600 MD EINDHOVEN, The Netherlands, Telex 35000 phtcnl, Fax. +31-40-723753

AS82

© Philips Export B.V. 1990

All rights are reserved. Reproduction in whole or in part is prohibited without the prior written consent of the copyright owner.

The information presented in this document does not form part of any quotation or contract, is believed to be accurate and reliable and may be changed without notice. No liability will be accepted by the publisher for any consequence of its use. Publication thereof does not convey nor imply any license under patent- or other industrial or intellectual property rights.

Printed in The Netherlands

9398 174 70011

Philips Components



PHILIPS